

## Hyperform Flares, JL Patent Pending

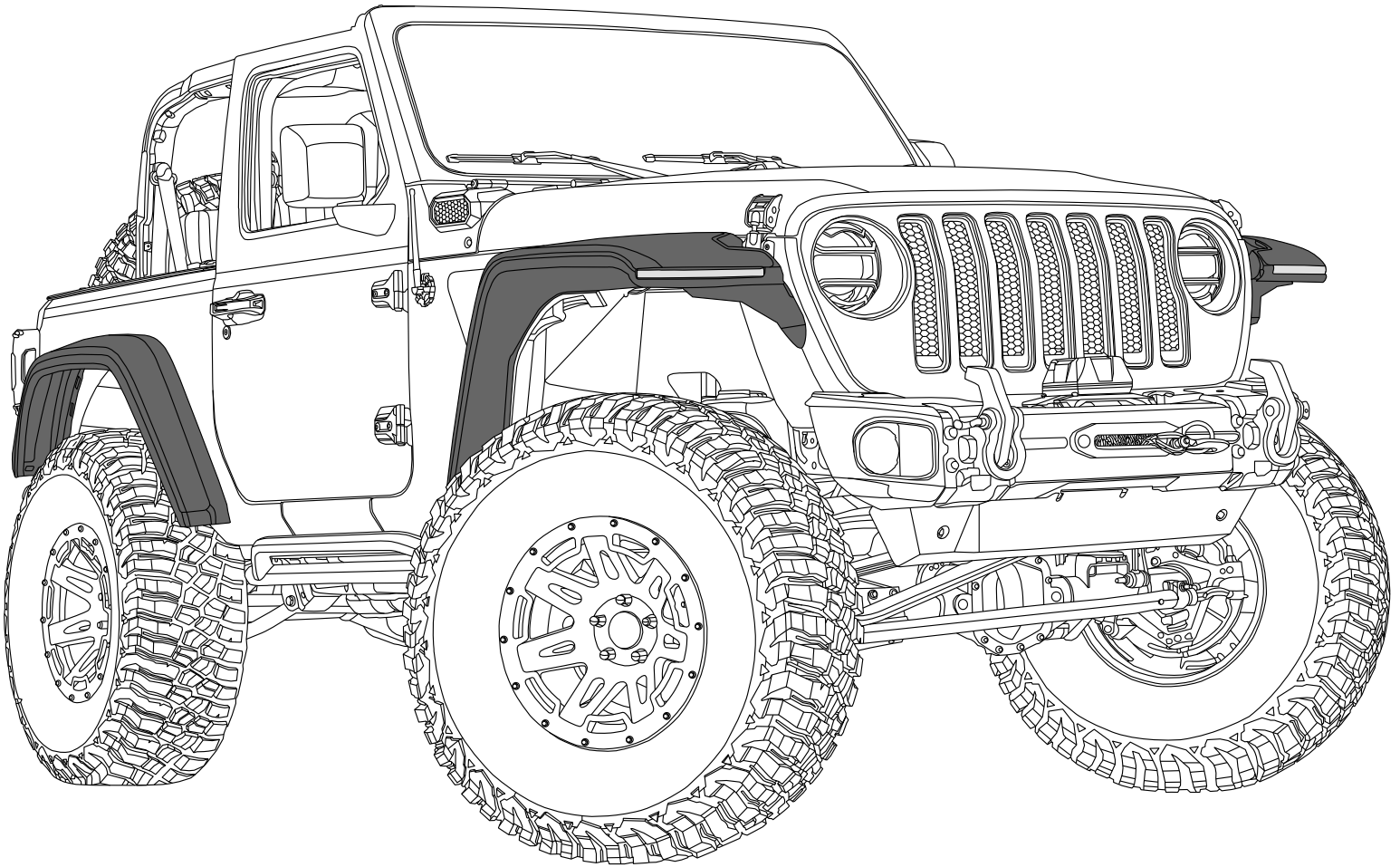

## Hyperperform Flares, JL Patent Pending

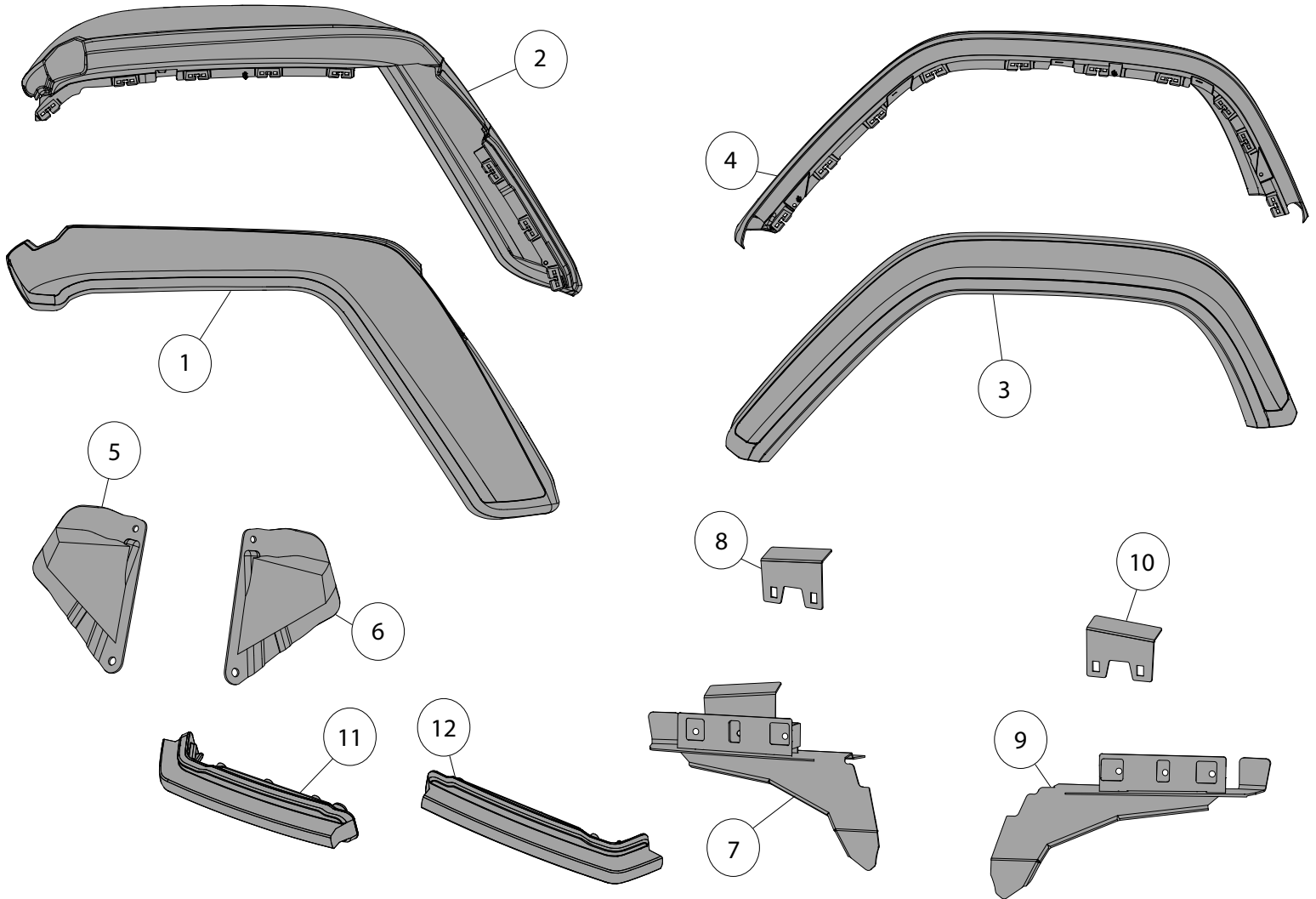

### Components

- |                        |     |                               |     |
|------------------------|-----|-------------------------------|-----|
| 1. Front Flare, LH     | (1) | 7. Light Bracket, RH          | (1) |
| 2. Front Flare, RH     | (1) | 8. Support Bracket, RH        | (1) |
| 3. Rear Flare, LH      | (1) | 9. Light Bracket, LH          | (1) |
| 4. Rear Flare, RH      | (1) | 10. Support Bracket, LH       | (1) |
| 5. Lower Stanchion, RH | (1) | 11. Daytime Running Light, RH | (1) |
| 6. Lower Stanchion, LH | (1) | 12. Daytime Running Light, LH | (1) |

## Hyperperform Flares, JL Patent Pending

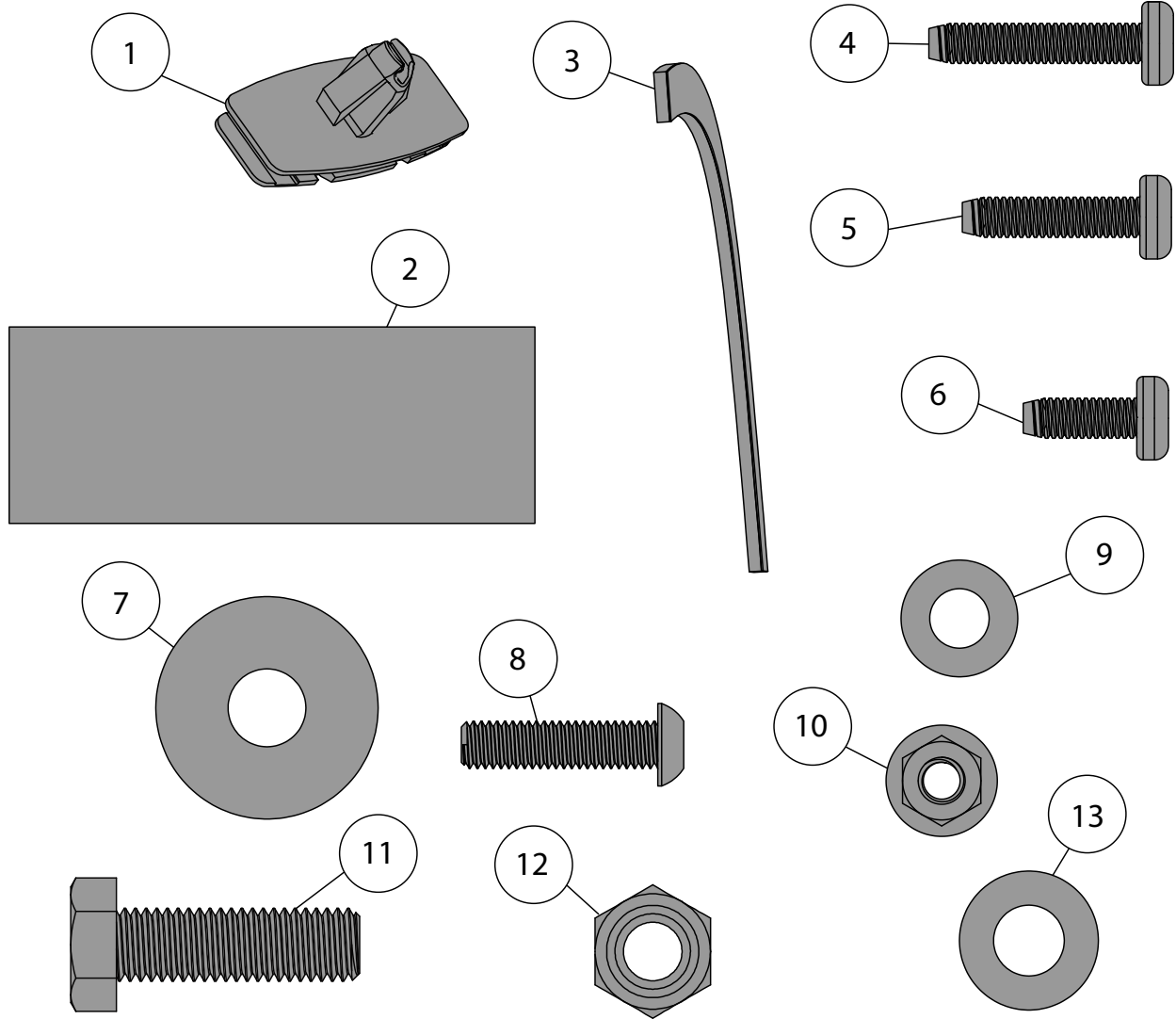

### Hardware

- |                                   |      |                        |      |
|-----------------------------------|------|------------------------|------|
| 1. Flare Clips                    | (36) | 8. M6 Button Head Bolt | (4)  |
| 2. Double Sided Tape              | (4)  | 9. M6 Washer           | (4)  |
| 3. Trim Foam                      | (4)  | 10. M6 Flange Nut      | (4)  |
| 4. Long M6 Thread Forming Screw   | (2)  | 11. M8 Bolt            | (4)  |
| 5. Medium M6 Thread Forming Screw | (2)  | 12. M8 Nut             | (8)  |
| 6. Short M6 Thread Forming Screw  | (2)  | 13. M8 Washer          | (12) |
| 7. M8 Oversized Washer            | (2)  |                        |      |

## Hyperform Flares, JL Patent Pending

1. Remove front and rear factory fender flares, flare supports, and wheel liner. Disconnect OE daytime running light (DRL) from wire harness. Retain all hardware.

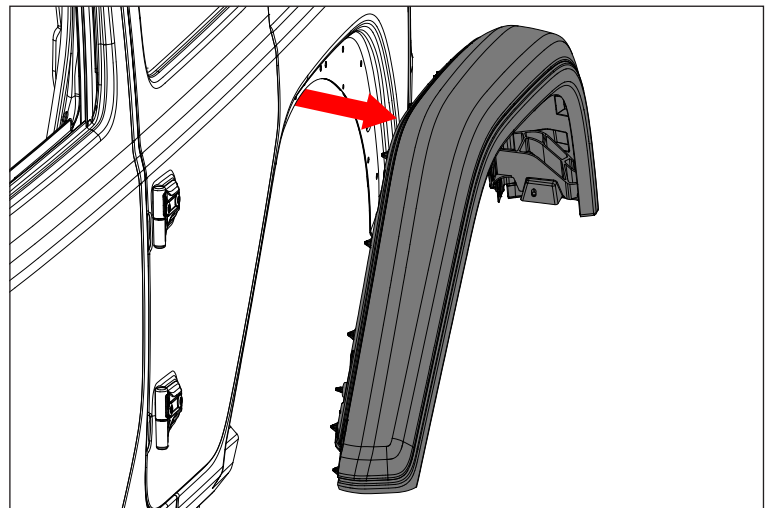
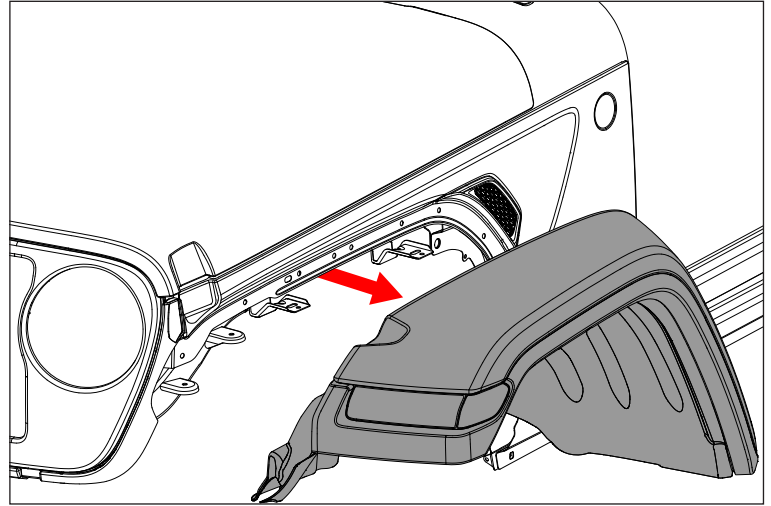

2. Using a clip removal tool, flat head screwdriver, or pry tool, remove any plastic clips still on fender. Thoroughly clean exposed fenders.

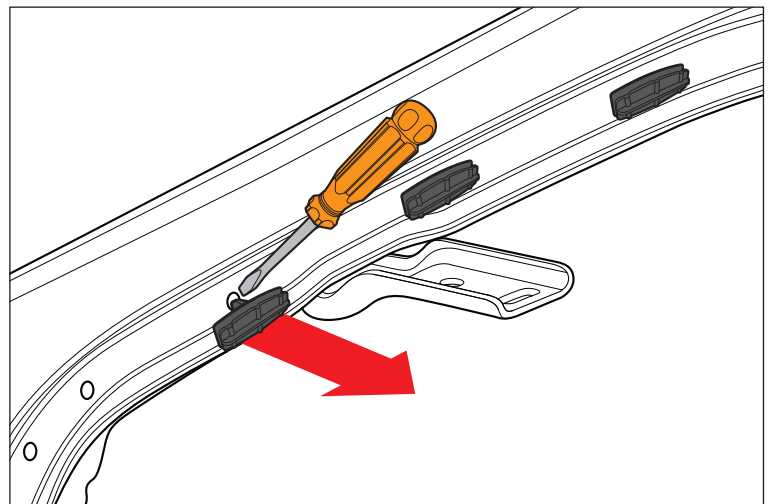

## Hyperperform Flares, JL Patent Pending

3. Disconnect primary and secondary batteries by removing wire leads from grounding post on fender and negative battery terminal.

**NOTICE** Skip to Step 7 if not reusing OE wheel liners.

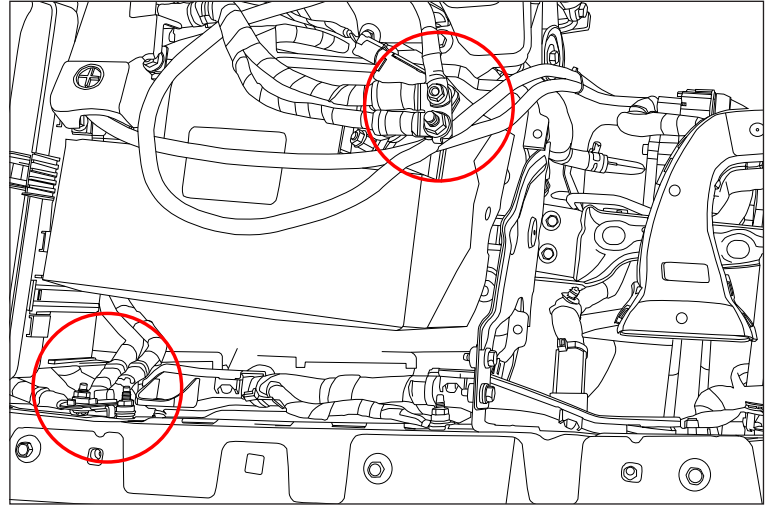

4. Using punch or drill with 5/16" bit, drill through plastic rivets along edge of flare and OE wheel liner.

**NOTICE** Do this for both front and rear flares.

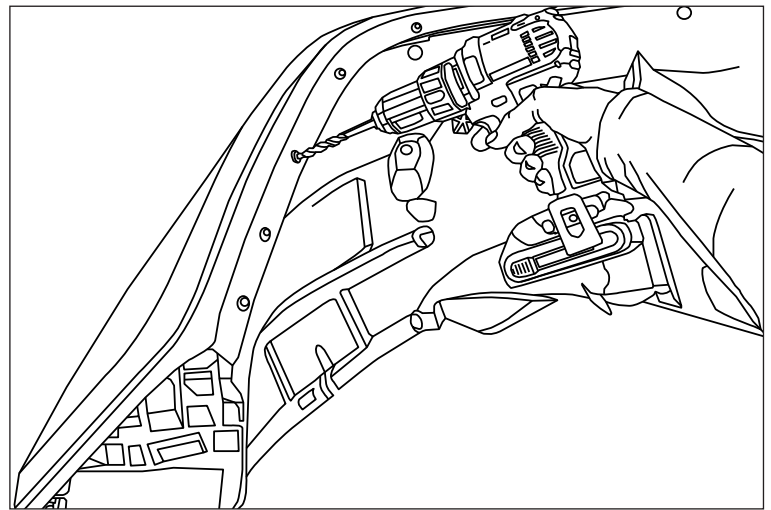

5. Position OE front wheel liner on vehicle. Using Jeep body as a guide, mark portion of front wheel liner protruding from vehicle body. Using a dremel, or other suitable cutting device, trim the OE front wheel liner along marked lines.

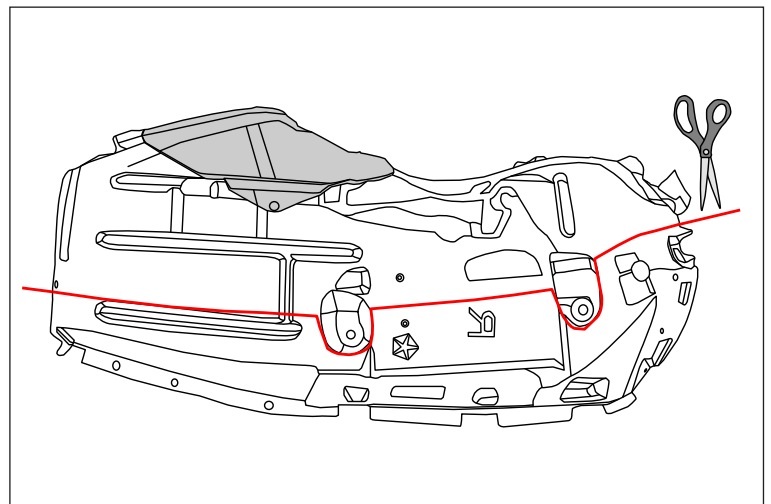

## Hyperperform Flares, JL Patent Pending

6. Reusing OE push rivets and hardware, reattach OE front wheel liners.

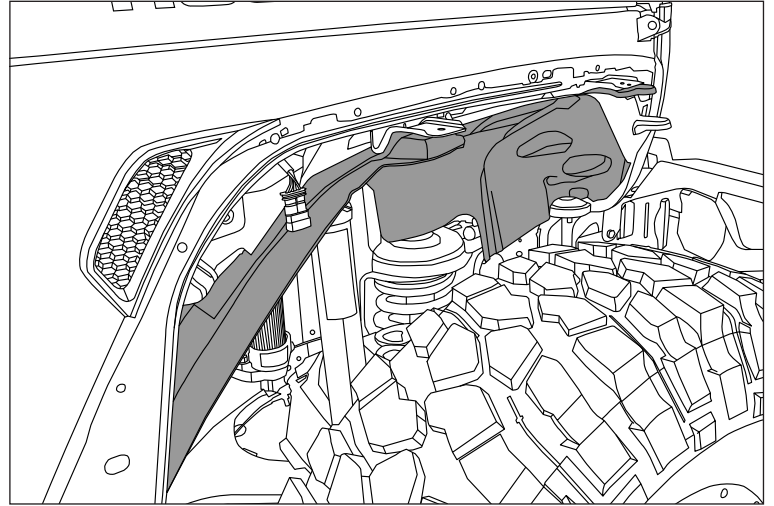

7. Apply adhesive promoter to the inside edge of Front Flare, approximately 1/4" from the edge.

8. Starting at one end, attach Trim Foam 1/4" from the top surface of flare.

**NOTICE** The Trim Foam will help protect the painted fender once the flares are installed.

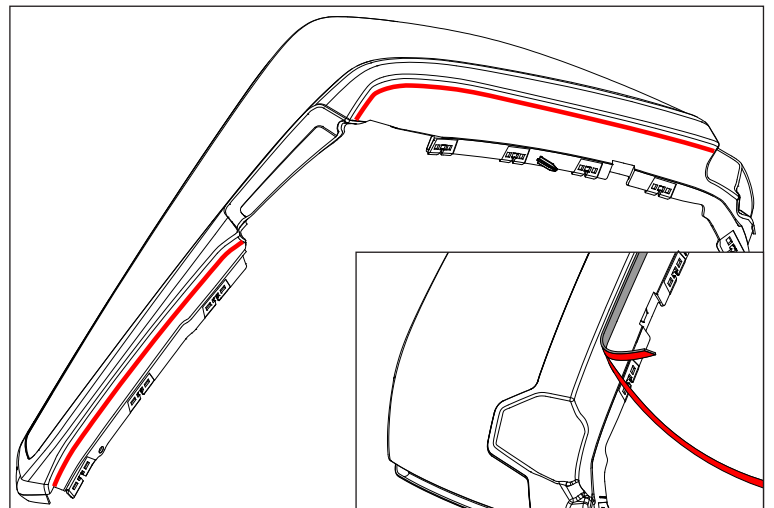

**NOTICE** Skip to step 11 if not reusing OE wheel liners.

9. Position OE rear wheel liner on vehicle. Using Jeep body as a guide, mark portion of rear wheel liner that protrudes from vehicle body. Using a dremel, or other suitable cutting tool, trim the OE rear wheel liner along marked lines.

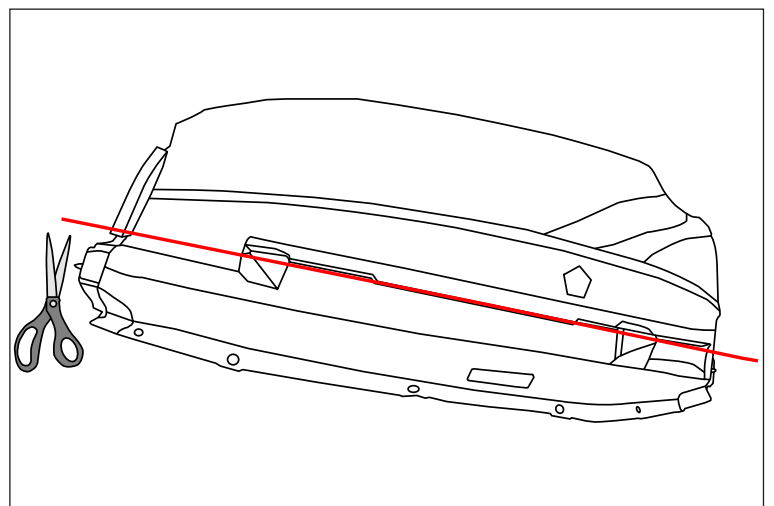

## Hyperform Flares, JL Patent Pending

10. Reattach OE rear wheel liner to vehicle, reusing OE push rivets.

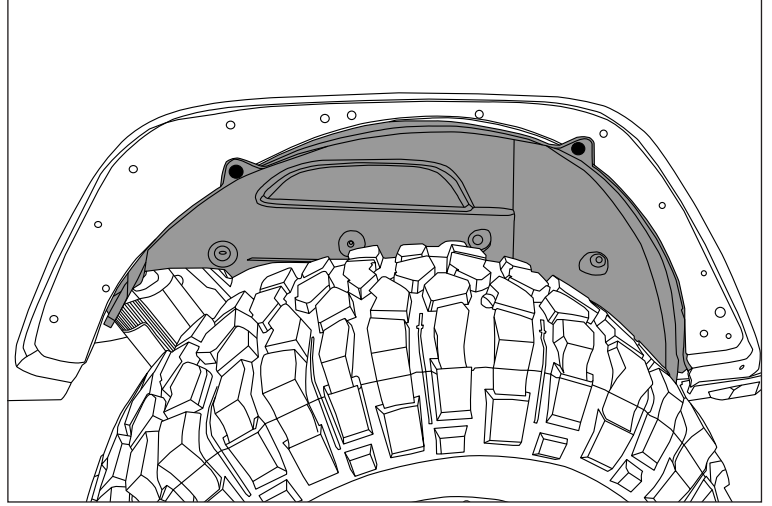

11. Apply adhesive promoter to the inside edge of Rear Flare, approximately 1/4" from the edge. Starting at one end, attach Trim Foam 1/4" from the top surface of flare.

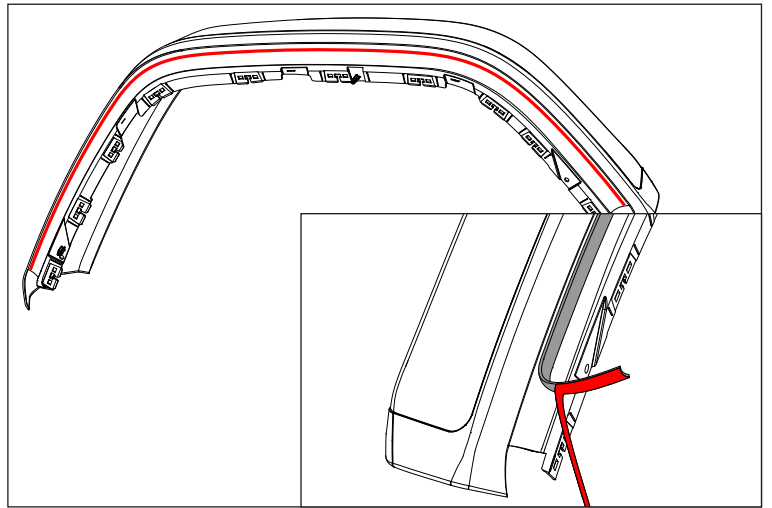

12. Attach Flare Clips to Front and Rear Flares.

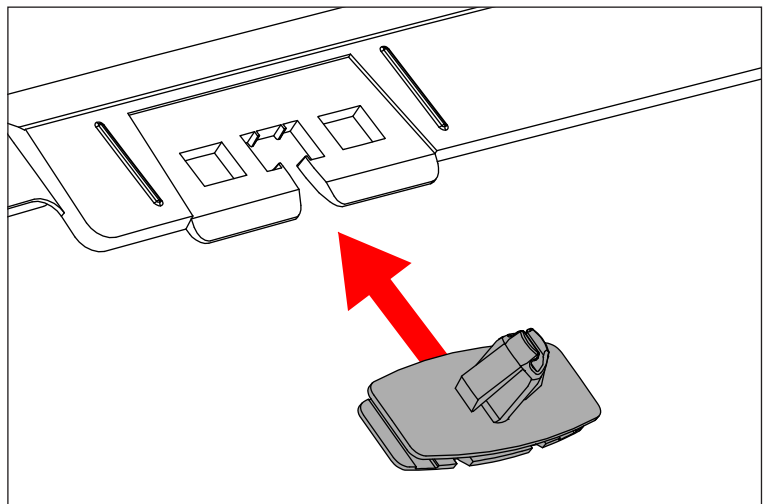

## Hyperform Flares, JL Patent Pending

13. Affix Front and Rear Flares to vehicle using clips.

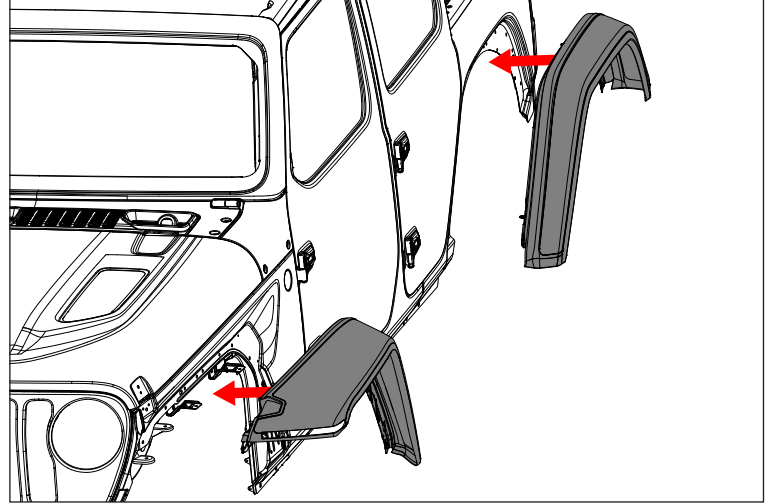

14. Apply adhesive promoter to the top of Lower Stanchion. Then attach Double Sided Tape.

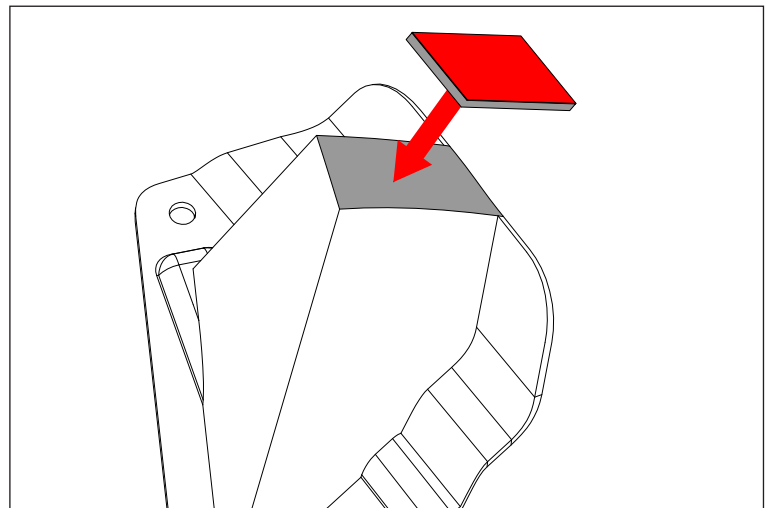

15. Using supplied M6 Flange Nut, M6 Bolt, M6 Washer, and M8 Oversized Washer, loosely attach Lower Stanchion to vehicle's front fender.

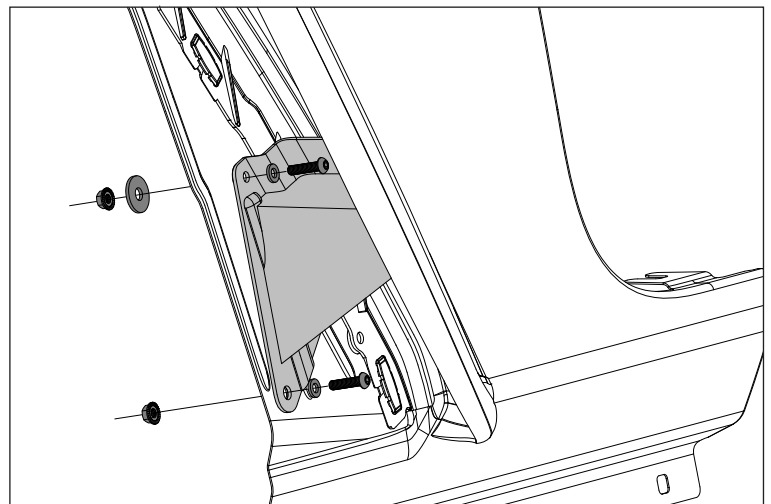



## Hyperform Flares, JL Patent Pending

16. Gently pull Front Flare away, and remove backing from Double Sided Tape. Press Front Flare and Lower Stanchion together.

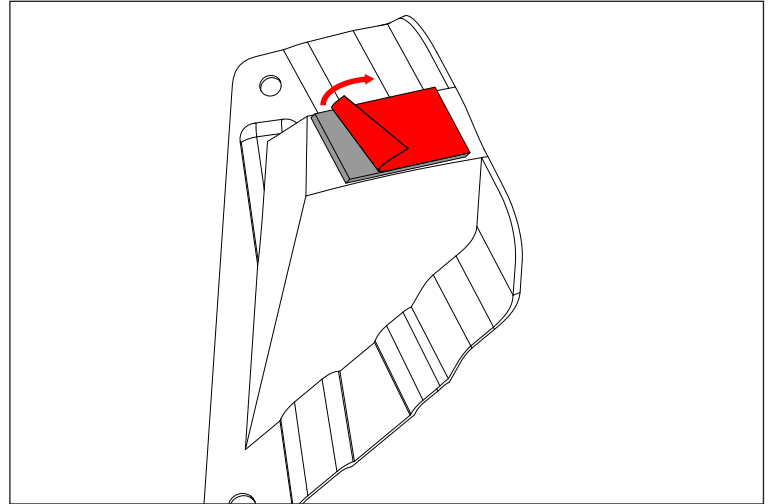

17. Attach Daytime Running Light to Light Bracket using supplied Thread Forming Screws.

**NOTICE** Three different size screws are used. Longest to shortest starting toward the center of vehicle.

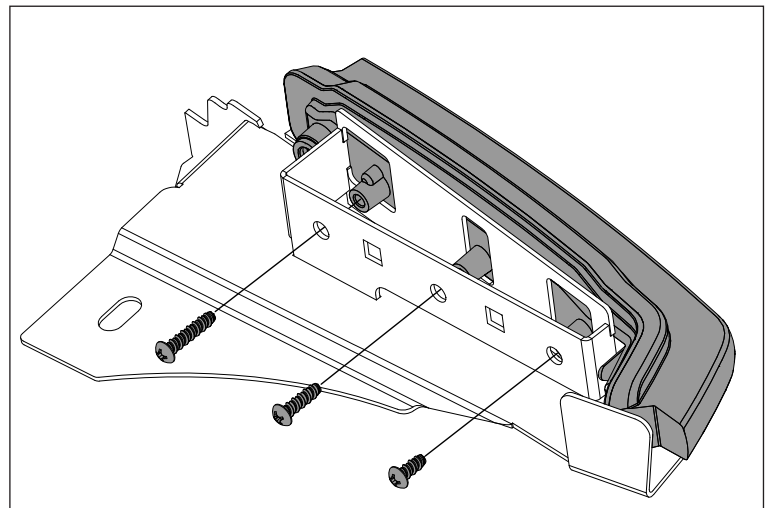

18. Connect light to OE wire harness. Using supplied M8 hardware, attach Light Bracket to vehicle. Position Daytime Running Light to align with opening in flare.

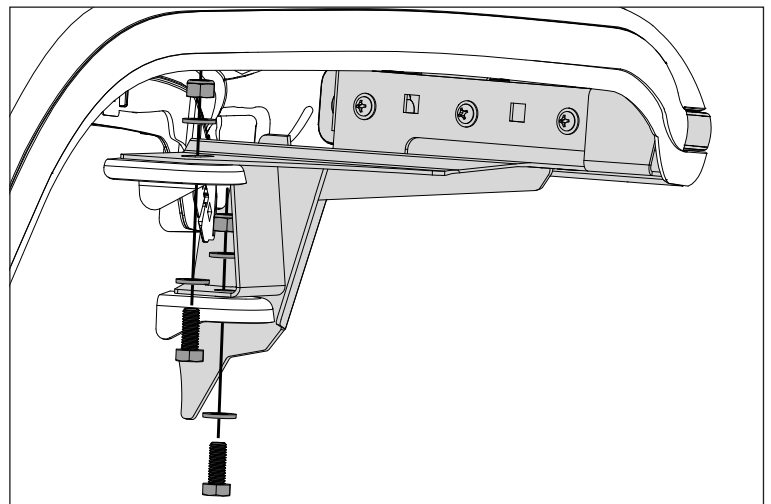

## Hyperform Flares, JL Patent Pending

19. Apply adhesive promoter to Support Bracket. Attach Double Sided Tape. Using supplied M8 Nut and M8 Washer, loosely attach Support Bracket to Light Bracket.

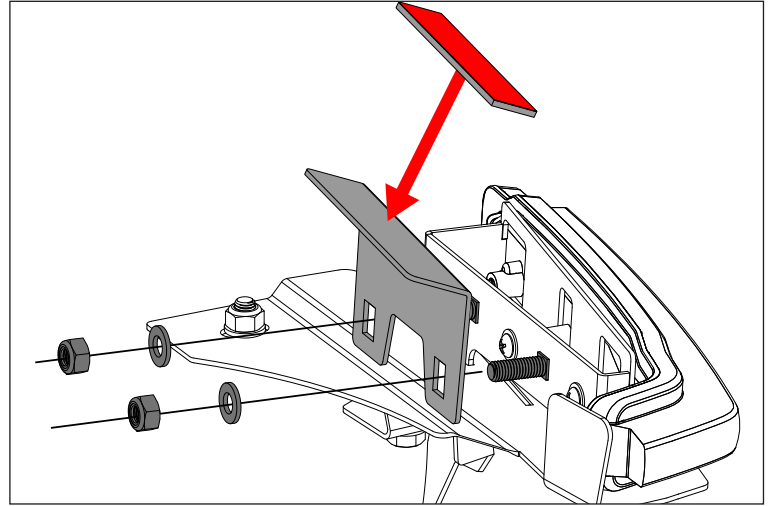

20. Position Support Bracket under flare and mark location. Add adhesive promoter to marked area.

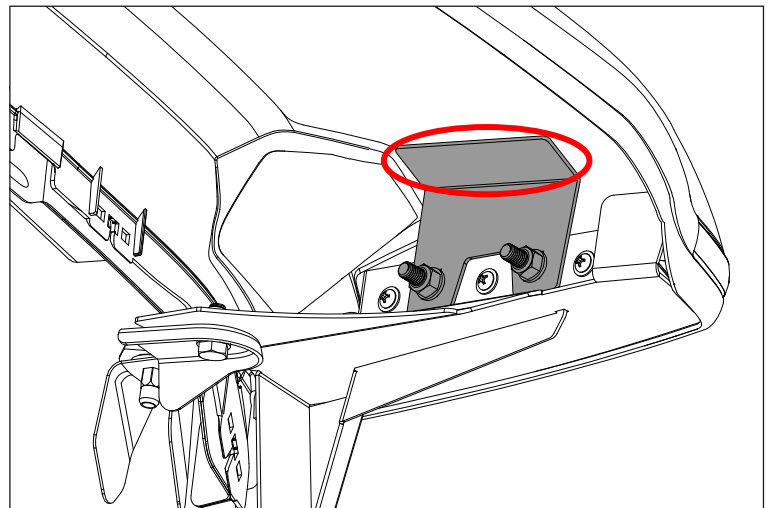

21. Peel backing from Double Sided Tape.

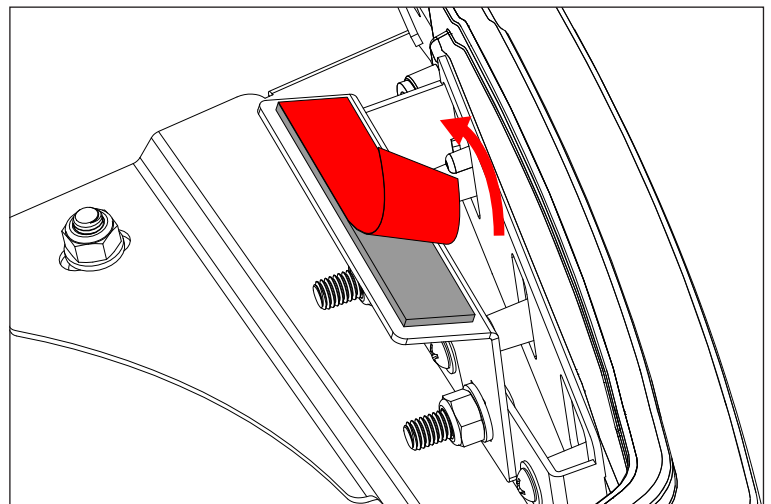

## Hyperperform Flares, JL Patent Pending

22. Press Support Bracket against Flare.

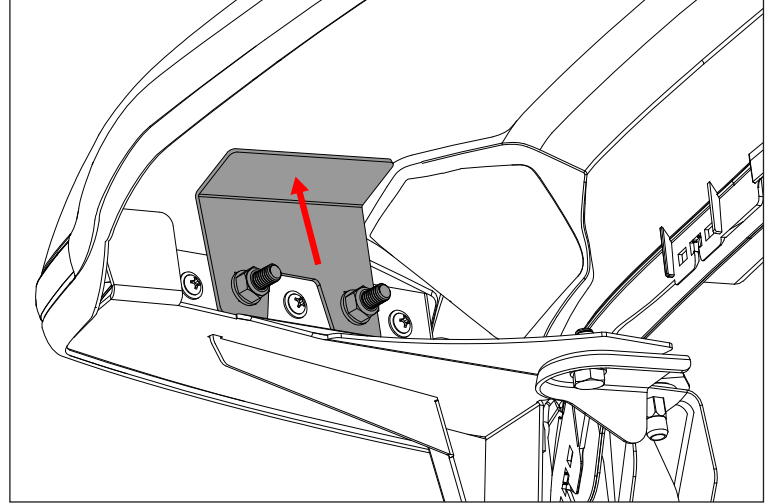

23. Tighten hardware. Reconnect primary and secondary Battery.

**NOTICE** Hyper flash or a DRL error may show on the dash after starting the vehicle. The vehicle's computer system should cycle any errors after a day or two of normal driving.

