



INSTALLATION INSTRUCTIONS FOR  
**4 Door Chevy Tahoe and GMC Yukon, 40903 (Set)**  
Extend-A-Fenders® 40024 & 40007 (pairs)

TOOLS REQUIRED FOR INSTALLATION:

- Electric Drill
- 3/16 and 11/64" Drill Bits
- #2 Phillips Driver Bit
- Grease Pencil
- Scissors
- Duct Tape

**IMPORTANT: READ BEFORE BEGINNING INSTALLATION**

**Verifying Fit** - Flares should be held to the vehicle surface to verify correct type and fit BEFORE beginning installation or painting. Small fit adjustments can be made by trimming (filing, sanding or scraping) excess plastic.

**Performance** - Using larger tires may increase the area required to turn the vehicle. Some Tire/Rim combinations may require lowering bump stops and/or installing steering stops to prevent tire shoulders from contacting the flare.

**Exhaust System** - Modifications may be necessary to maintain a minimum 4" clearance between flares and exhaust pipes. Exhaust gases should not vent directly onto flares.

**DO NOT USE:** Loctite, SuperGlue, or similar products on the hardware or the flares.

---

**FLARE INSTALLATION PROCEDURES**

**Step 1: Painting**

- It is recommended that painting (when desired) be done prior to installation.
- Sand (optional) before application of paint.
- Clean outer surface with a good grade degreaser. **Do not use** lacquer thinner or enamel reducer as a degreaser. Wipe outer surface thoroughly with a tack rag prior to painting.
- Paint flares using a high quality lacquer, enamel, or polyurethane automotive paint. Application of a primer coat is optional. Painting edge trim is not recommended.

**Step 2: Preparing the Work Area (front and rear)**

- Remove factory flare, bumper fender extension, and any wheel well trim within 4" of the rim.

**Step 3: Edge Trim Installation**

- Peel two to three inches of red vinyl backing away from edge trim tape. Applying the adhesive side of the edge trim to the inner side of the flare, affix the edge trim to the top edge of the flare (the portion that comes in contact with the side of the vehicle). Press edge trim into place along the top edge of the flare in one-foot increments, pulling red vinyl backing free as you continue to work your way around the top edge of the flare.

- Repeat for remaining flares.

**Step 4: Fitting Flare to Body Side Molding**

On vehicles with hard rubber body side moldings, it will be necessary to trim the moldings.

- Place flare into wheel well opening and mark a line where the flare intersects the molding.

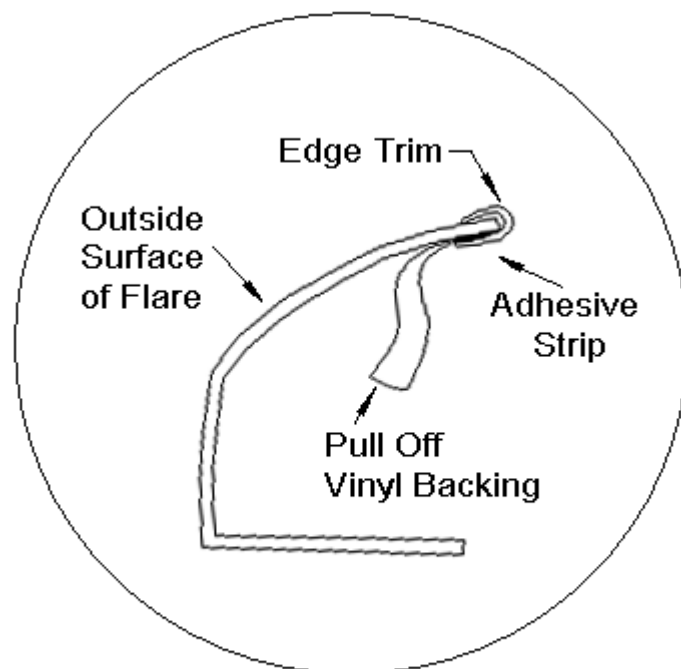

**Illustration #1**

- (B) Using a wide putty knife, separate the molding from the body 2"-3" beyond the line marked on the molding.
- (C) Protect the vehicle surface with many layers of duct tape and cut the molding 1/4" out from marked line. (Strong scissors are recommended for cleanest cut.)

**Step 5: Flare Installation (Front)**

- (A) Pre-drill the Front Parts with a 3/16" drill bit using the indents formed into the parts as a guide
- (B) Hold flare in place on fender.
- (C) Applying pressure to the outside surface of the flare, fasten the flare to the vehicle with kit supplied drill tip screws.

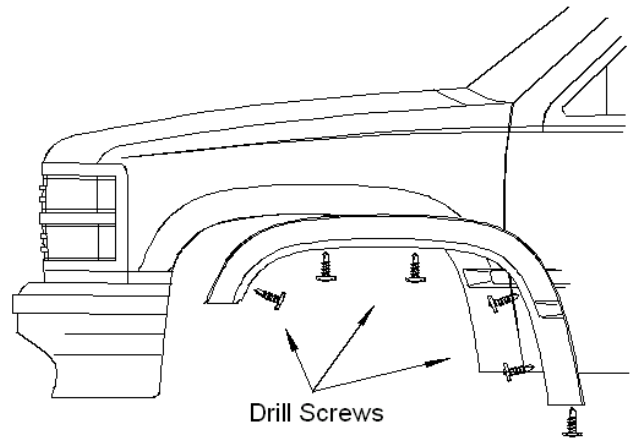

ILLUSTRATION #2

**Step 5: Flare Installation (Rear)**

There are three parts to each rear flare: the Inner Door Piece, the Outer Door Piece, and the Rear Part. Special attention must be given to assure proper alignment of these parts to each other.

(A) Rear Part Installation:

1. Pre-drill the Rear Parts with a 3/16" drill bit using the indents formed into the parts as a guide.
2. Align the front edge of the Rear Part with the door seam, apply pressure and fasten it to the fender using drill tip screws.

(B) Door Piece Installation:

3. With the door closed, apply a strip of double sided tape to the outside of the door, starting with the door edge, and following the door edge contour to the bottom of the door. Then peel the red vinyl backing away from the tape. See illustration #4
4. Align the top end of the Inner Door Piece with the door edge, and the clip slots to the edge of the door contour, place the Inner Door Piece on the door over the double stick tape and press firmly into position.
5. While holding the Inner Door Piece, open the door and adhere the supplied Mylar tabs on the inside of the door edge contour covering the slots in the door piece. See illustration# 4.
6. Install the supplied clips by pushing the long side of the clip into slot of the flare, while also tucking the Mylar tab into the slot and the edge of the door. See illustration #3.
7. Position the Outer Door Piece on the Inner Door Piece.
8. Holding in position, drill four 11/64" holes through both parts using indents in Outer Door Piece as a guide.
9. Secure the Outer Door Piece to the Inner Door Piece using four expanding rivets. See Illustration #3.

**DOOR PIECE CROSS SECTION**

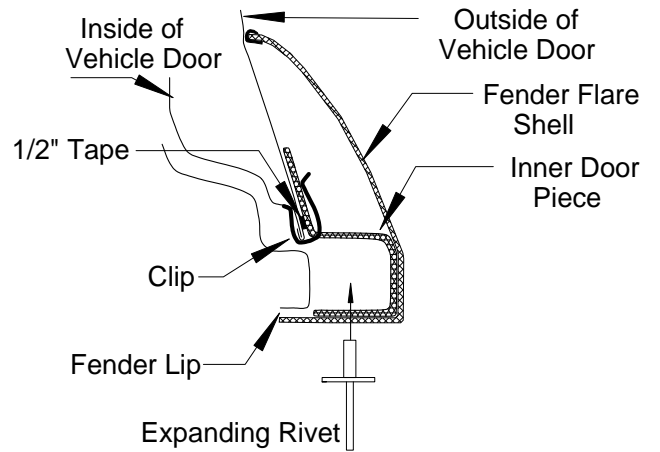

ILLUSTRATION #3

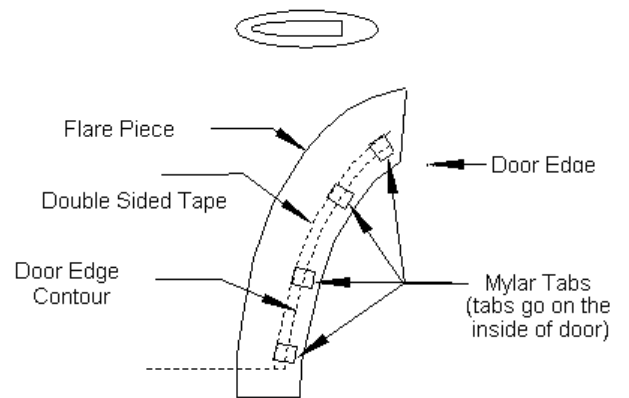

ILLUSTRATION #4