

Rear Part # 40062

Chevy / GMC Pickup
Suburban / GMC
2DR Tahoe / Yukon

STEP 1.

Prior to Installation:

- A) Bushwacker only approves installing the flares according to these written instructions with the hardware provided. **WARNING:** Failure to install according to these instructions will invalidate the warranty. This includes, but is not limited to using alternative installation methods, hardware, or materials. **DO NOT USE:** Loctite, SuperGlue, or similar products on the hardware or the flares.
- B) **Fit:** Verify you have ordered the right flares for your vehicle make and model and check their fit.
- C) **Painting :** (Optional) if paint is desired it must be done prior to installing flares on the vehicle, clean outer surface with a good grade degreaser. **DO NOT USE LACQUER THINNER OR ENAMEL REDUCER AS A DEGREASER.** Wipe outer surface thoroughly with a tack rag prior to paint. Paint flares using a high quality enamel, or polyurethane automotive paint. (Application of a primer coat is optional) If painting edge trim (not recommended) use a flex additive.
- D) **Performance:** Using larger Tires may increase the area require to turn the vehicle. Some Tire/Rim combinations may required lowering bump stops and or installing steering stops to prevent tire from contacting flare.
- E) **Exhaust System:** Modifications may be necessary to maintain a minimum 4" clearance between flares and exhaust pipes. (Exhaust gases should not vent directly onto flares)



TOOLS FOR EASY INSTALLATION

- Utility Knife
- #2 Short Phillips Screwdriver
- ½ Wrench
- T45 Torx Bit
- Marker

FLARE INSTALLATION PROCEDURES

STEP 2:

Preparing the Work Area (Front and Rear)

Remove factory fender trim and mud flaps (when installed).

STEP 3: Edge Trim Installation (See Illustration #1)

- A) Peel two to three inches of red vinyl backing away from edge trim tape. Applying the adhesive side of the edge trim to the inner side of the flare, affix the edge trim to the top edge of the flare (the portion that comes in contact with the side of the vehicle).
- B) Press edge trim into place along the top edge of the flare in one-foot increments, pulling red vinyl backing free as you continue to work your way around the top edge of the flare.

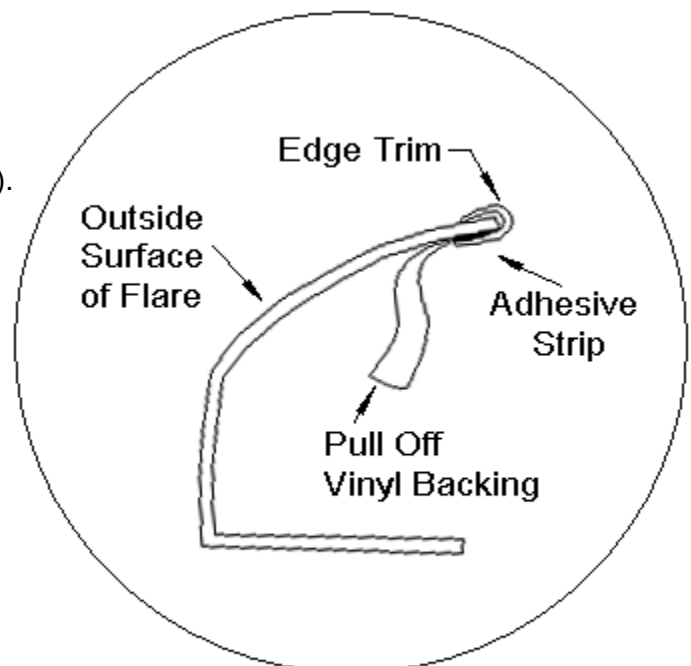

Illustration #1

STEP 4: (Front and Rear Flare) Stainless Steel Screw Installation (See Illustration # 2)

- A) Insert stainless steel screw and washer into front of flare, secure with nyloc nut, using a T45 Torx bit. (See Illustration #2)

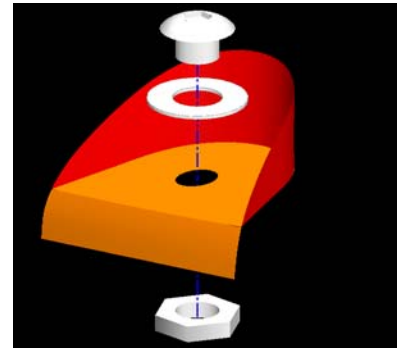

Illustration # 2

STEP 5: Preparing Front and Rear Flare Installation (See Illustration # 3)

- A) Remove factory fender trim, front fender body side molding and mud flaps (When installed).
 B) Trim body side molding rear (when installed) so flare fits base sheet metal. Hold flare up to wheel well opening and mark a line on body side molding where flare overlaps.
 C) Remove flare, mark cut line 1/4" beyond overlap line. Use blow dryer to heat molding.
 D) Slide 6" wide knife between the molding and body of vehicle.
 E) Carefully cut on marked line with a utility knife, using the putty knife as a guard against the vehicle.
 F) Sand molding to desired finished edge.

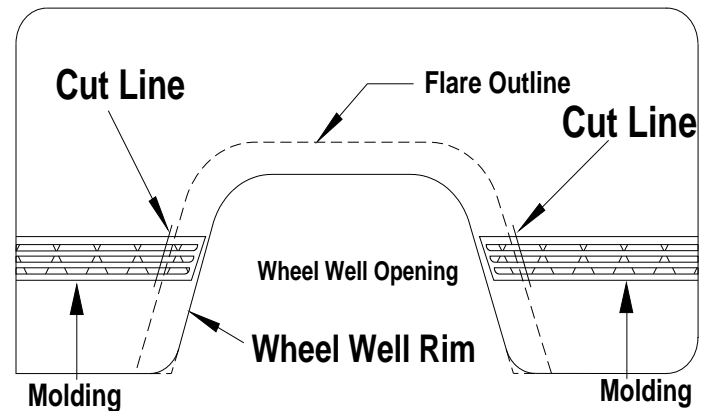

Illustration # 3

STEP 6: Front Flare Installation (See Illustration # 4)

- A) Hold flare in position with moderate pressure. Using the holes in the flares as a guide, mark wheel well lip where each hole is.
 B) Remove flare and stick a black Mylar tab over each marked location. Slide supplied clamps over each tab location. (See Illustration #6)
 C) Hold flare in position and line up the holes in flare to the threaded holes in clamps. Starting with the two top holes, start the supplied screws, but keep loose.
 D) Ensuring the flare is properly located on fender, install remaining screws. Applying moderate pressure to outside surface of flare, tighten screws, beginning with the two top locations and then the two bottom screws.

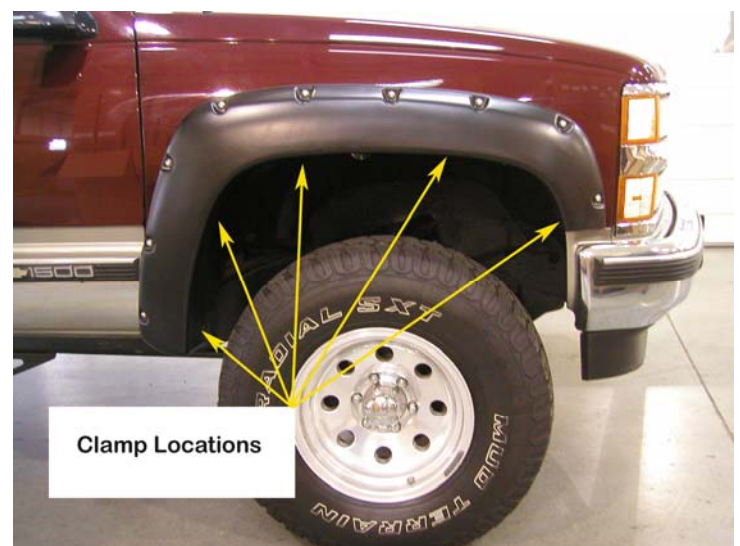

Illustration # 4

STEP 7: Rear Flare Installation (See Illustration #5)

- A) Hold flare in position with moderate pressure. Using the holes in the flares as a guide, mark wheel well lip where each hole is.
- B) Remove flare and stick a black Mylar tab over each marked location. Slide supplied clamps over each tab location. (See Illustration #6)
- C) Hold flare in position and line up the holes in flare to the threaded holes in clamps. Starting with the two corner holes, start the supplied screws but keep loose.
- D) Insuring the flare is properly located on fender, install remaining screws. Applying moderate pressure to outside surface of flare, tighten screws, beginning with the two corner locations and then the two bottom screws. Tighten the top center screw last.



Illustration # 5

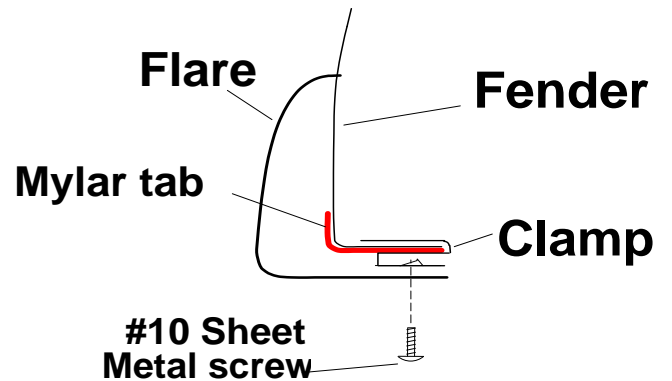

Illustration # 6