

## Toyota 2WD & 4WD T-100 Set Part # 31910

### Step 1:

#### Prior to Installation:

- A) Bushwacker only approves installing the flares according to these written instructions with the hardware provided. **WARNING:** Failure to install according to these instructions will invalidate the warranty. This includes, but is not limited to using alternative installation methods, hardware, or materials. **DO NOT USE:** Loctite, SuperGlue, or similar products on the hardware or the flares.
- B) **Fit:** Verify the fit of the flares to vehicle. **(Some filing, sanding, or cutting may be necessary to ensure proper fit).**
- C) **Painting:** (Optional) if paint is desired it must be done prior to installing flares on the vehicle clean outer surface with a good grade degreaser. **DO NOT USE LACQUER THINNER OR ENAMEL REDUCER AS A DEGREASER.** Wipe outer surface thoroughly with a tack rag prior to paint. Paint flares using a high quality enamel, or polyurethane automotive paint. (Application of a primer coat is optional) If painting edge trim (not recommended), use a flex additive.
- D) **Performance:** Using larger Tires may increase the area required to turn the vehicle. Some Tire/Rim combinations may require lowering bump stops and or installing steering stops to prevent tire from contacting flare.
- E) **Exhaust System:** Modifications may be necessary to maintain a minimum 4" clearance between flares and exhaust pipes. (Exhaust gases should not vent directly onto flares)



#### TOOLS FOR EASY INSTALLATION

- Jack and Jack Stands (optional)
- 10mm Metric Hex Wrench
- Utility Knife
- Drill and 5/16" Drill Bit

---

## FLARE INSTALLATION PROCEDURES

### Step 2: Edge Trim Installation (See Illustration #1)

- A) Remove factory installed edge trim when necessary.
- B) Peel two to three inches of red vinyl backing away from edge trim tape. Applying the adhesive side of the edge trim to the inner side of the flare, affix the edge trim to the top edge of the flare (the portion that comes in contact with the vehicle). **See Illustration #1**
- C) Press edge trim into place along the top edge of the flare in one-foot increments, pulling red vinyl backing free as you continue to work your way around the top edge of the flare.

### Step 3: Preparing the Work Area

- A) Remove wheel well molding when necessary.
- B) Pre-fit flare parts to wheel well area and trim if necessary. Hard rubber body side molding can be trimmed to avoid interference with flare using a utility knife. Protect vehicle finish with tape during all trimming operations.

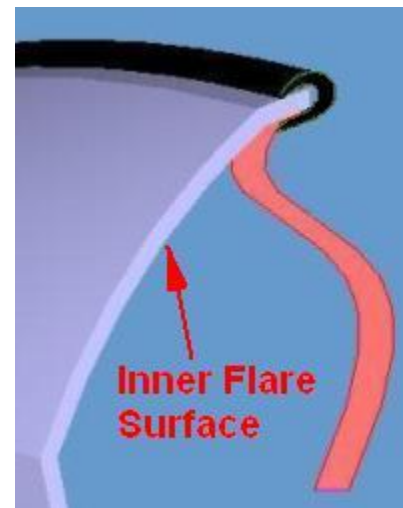
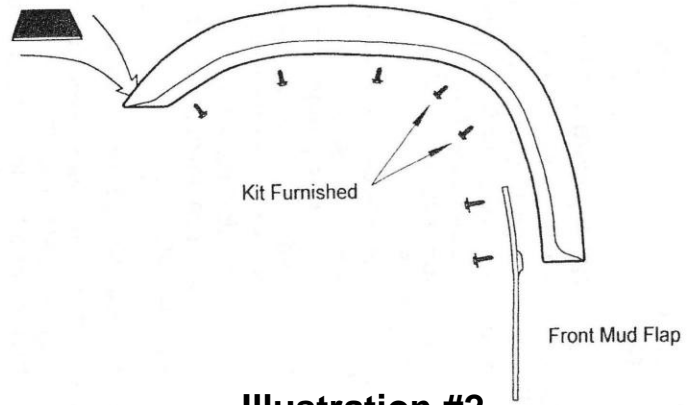

Illustration #1

**Step 4: Flare Installation (Front)**  
**(See Illustrations #2 & #3)**

- A) Remove and save screws used to secure liner, factory edge trim, and mud flaps.
- B) Drill seven 5/16" holes along flare inner edge using indents as a guide.
- C) Remove one side of protective paper on double-stick tab and place on inside front flare flat. Remove remaining protective paper and place flare in position with fender and flare holes aligned.
- D) Secure to fender along five forward hole locations using screws removed in Step 4A and two 3/4" screws (provided with kit). **See Illustrations #2 & #3.**
- E) Place mud flap in proper position and mark rear surface "contour lip" with it interferes with flush fit.
- F) Trim contour lip on rear surface of mud flap to allow flush fit against surface of flare.
- G) Secure mud flap and lower rear portion of flare using 1" screws removed in Step 4A.

Double Stick Tab  
on Inside Flat



**Illustration #2**

**Step 5: Flare Installation (Rear)**  
**(See Illustrations #4, #5 and #6)**

- A) Remove and save screws used to hold mud flap. Any other wheel well trim and fasteners can be removed and discarded
- B) Place five plastic screw retaining clips around fender roll-under lip. Clips should be placed with "post" to inside and aligned with factory hole locations. **See Illustration #4.**
- C) Drill six 5/16" holes along flare inner edge using indents as a guide.
- D) Remove one side of protective paper on double-stick tabs and place on inside of front and rear flare "flats." Remove remaining protective paper and place flare in position with fender and flare holes aligned.
- E) Secure flares to fender using five kit supplied screws. **See Illustration #5.**
- F) Place mud flap in proper position and mark rear surface contour lip where it interferes with flush fit.
- G) Trim contour lip on rear surface of mud flap to allow flush fit against surface of flare.
- H) Secure mud flap and lower rear portion of flare using screws removed in Step 5A.

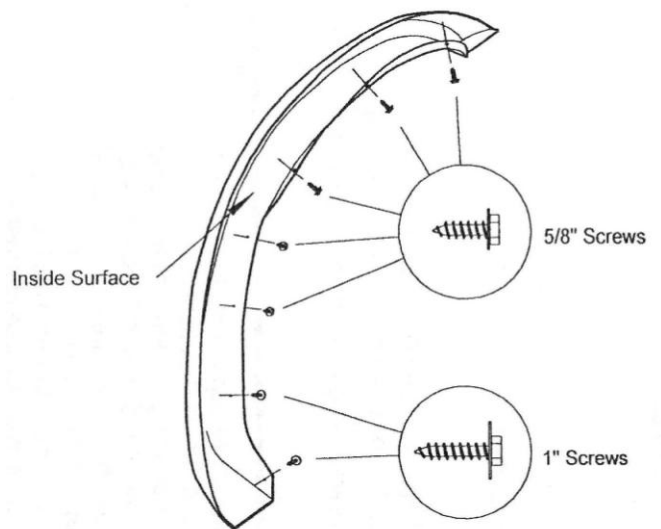

**Illustration #3**

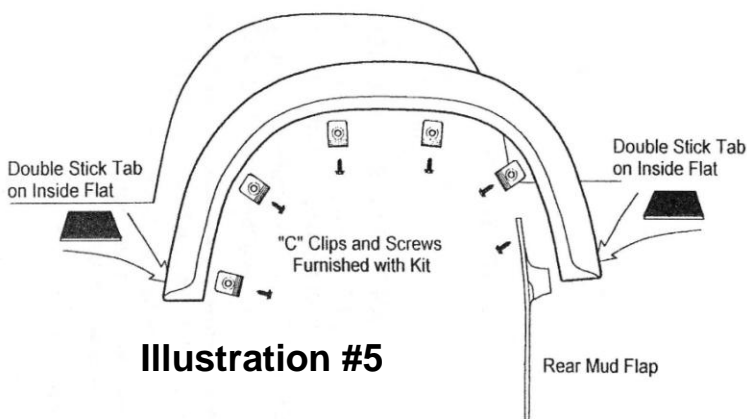

**Illustration #5**

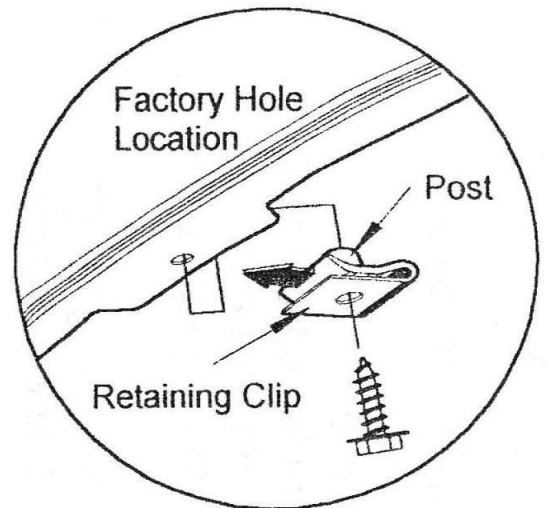

**Illustration #4**