



Wedge-Latch® Coupler

Read, Understand, Follow and Save These Instructions

Read, understand and follow all of these instructions and warnings (Instructions) before installing and using this product. Install and use this product only as specified in these instructions. Improper installation or use of this product may result in property damage, serious injury, and/or death. Never allow installation or use of this product by anyone without providing them with these instructions. You must read, understand and follow all instructions and warnings for any product(s) to which this product is used in conjunction with or installed. Save these instructions with the product for use as a reference for any future installation and use of the product.



Failure to follow these warnings and instructions may result in property damage, serious bodily injury, and/or death.

- Purchaser/owner must ensure that product is installed according to these instructions. Purchaser/owner must not alter or modify the product.
- Operator and bystanders should never position any part of body under any portion of this product or the load being supported.
- Do not allow children to play on or around this product or the load being supported.
- Weigh your trailer plus added load. Do not exceed lesser of mounting bracket, coupler, hitch, vehicle, ball, or trailer weight ratings (including load).
- Use only the proper ball for this coupler as indicated on the coupler body.
- Always secure load, vehicle and trailer (by blocking wheels) before latching/unlatching coupler.
- Use caution when uncoupling as tongue may rise suddenly due to negative tongue load.
- After installing mounting bracket and/or coupler, if coupler operation has been impaired in any way, do not use it.
- Keep the ball pocket and mechanism clean. When parking or storing your trailer, keep the coupler off the ground so dirt and/or other foreign material will not build up in the coupler ball pocket.
- Do not tow if ball is not fully seated and/or coupler is not closed.
- All welding must be performed by a certified AWS welder.

Before Towing:

- Check vehicle, mounting bracket, hitch, hitch ball and coupler for signs of wear or damage and that the coupler handle opens and closes freely. If coupler and/or mounting bracket is deformed or damaged, replace complete coupler and mounting bracket.
- Replace bent, broken, or worn parts before using this product.
- Close coupler securely by ensuring that the hitch ball is fully seated in the coupler ball pocket and the pin is inserted behind the collar or through latch.
- Check mounting bracket hardware for wear and proper tightness. Replace bent, broken, or worn hardware. Tighten hardware to appropriate SAE proofload specifications (See table specs). Use only grade 5 hardware.
- Make sure that the trailer safety chains are properly connected to the towing vehicle and trailer according to SAE J684.
- Make sure that all trailer lighting is hooked up and working properly.

Installation Instructions

Warning: Failure to follow all installation instructions could result in coupler failure

Before mounting the coupler confirm that there will be no interference from the tow vehicle, tongue, ground, and any other mounted accessories while stationary or in motion. Before installing, check for interference in open and closed positions. Check for interference again after installation is complete. All welding must be performed by an AWS certified welder. The coupler must be rigidly attached to the trailer in order for the coupler to support its maximum rated load according to SAE J684. After installation, check to make sure that coupler operation has not been impaired in any way. Do not use coupler if its operation has been impaired. If coupler is to be primed/painted after installation, make sure excess paint/primer buildup is removed from ball pocket and latching mechanism.

Adjustable Height Channel (“Mounting Bracket”):

If tongue height is 6” or less, gussets are required. Mounting bracket must be centered on tongue and remain vertical after installation. A 1/4” minimum fillet weld is required all around. **Bolting Instructions:** This coupler must be secured using two sets of holes in the mounting bracket. Using the hardware provided, insert the two (2) 5/8” x 5” grade 5 bolts through desired mounting bracket holes and the holes of the coupler. Tighten lock nuts to 100-110 ft. lbs.

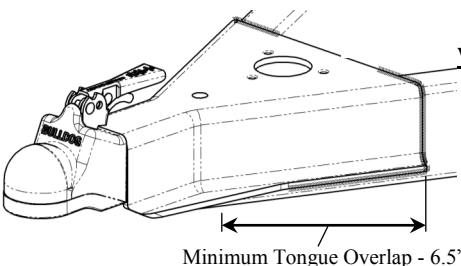
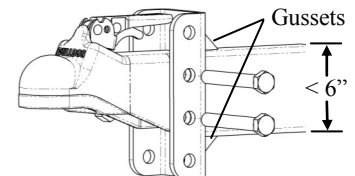

Weld-on Instructions:

All welding must be performed by an AWS certified welder. This coupler can only be used with 50 degree trailer tongues. Assure that the coupler internal stop is butted against the end of trailer tongue for maximum overlap before securing. A minimum coupler/tongue overlap of 6.5” is required. Weld on both sides and the top using a 3/16” minimum fillet weld as shown. If coupler is to be primed/painted after installation, make sure excess paint/primer buildup is removed from ball pocket and latching mechanism.

Bolt-on Instructions:

A-Frame Couplers: Assure that the coupler internal stop is butted against the end of trailer tongue for maximum overlap before securing. The number and size of fasteners required must be specified by the trailer manufacturer. Using available mounting holes in coupler housing, bolt coupler to tongue members using grade 5 hardware with locknuts. Torque grade 5 bolts with locknuts to appropriate SAE proof load specifications (See table specs). No deformation of trailer tongue end allowed.

Flat-Mount Couplers: Insert four (4) 5/8” grade 5 bolts through coupler and mount plate. Tighten bolts to 150 ft. lbs.

Torque Specs
Ø 3/8” - 23 ft. lbs.
Ø 1/2” - 55 ft. lbs.
Ø 5/8” - 110 ft. lbs.

Maintenance

Keep ball pocket and mechanism clean. The following procedures should be performed at least annually:

- Check set screw torque
- Grease ball pocket
- Oil pivot points with SAE 30 wt. motor oil
- Inspect retaining pin and replace if necessary

Operation

To Couple:

- 1) Block trailer wheels.
- 2) Align hitch ball beneath coupler.
- 3) Open coupler locking lever. While holding locking lever open, lower the coupler over the hitch ball until ball is fully seated into the ball pocket.
- 4) If locking lever is pinned open, remove pin. Move locking lever to the closed position. Check that the latch is engaged by lifting up on back of locking lever. Also, check that the hitch ball is fully seated and ball clamp is below the ball. If the ball is not seated with lever in the closed position and latch engaged, **DO NOT TOW**. Repeat the above steps.
- 5) **OPTIONAL:** Place a 5/16" pin or lock in hole shown

To Uncouple:

- 1) Block trailer wheels.
- 2) Open locking lever. While holding locking lever fully open, raise trailer off of hitch ball. **NOTE:** A 5/16" diameter pin can be used to hold the locking lever open.
- 3) Return handle to closed position.

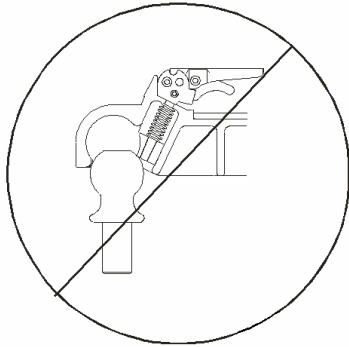
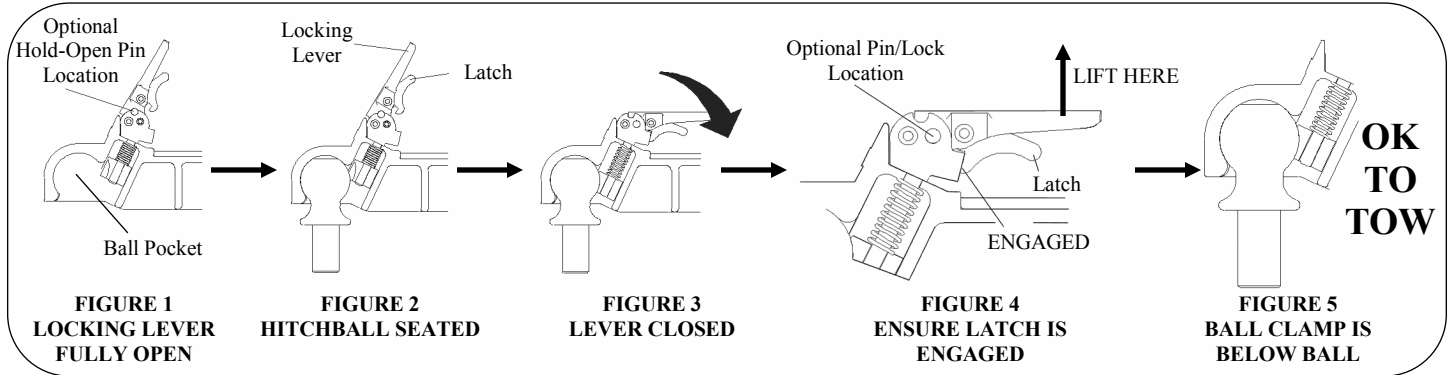

BALL NOT SEATED. DO NOT TOW

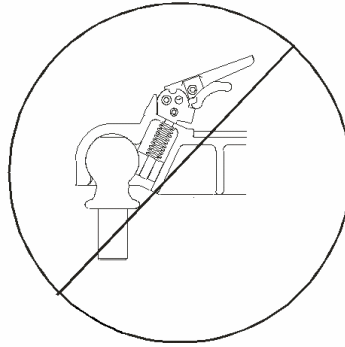

LATCH NOT ENGAGED. DO NOT TOW

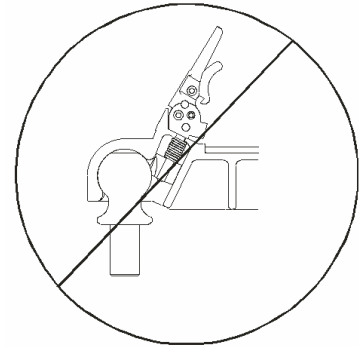

LEVER NOT CLOSED. DO NOT TOW