



Bulldog® BX1 Gooseneck Coupler

Read, Understand, Follow and Save These Instructions

Read, understand and follow all of these instructions and warnings (Instructions) before installing and using this product. Install and use this product only as specified in these instructions. Improper installation or use of this product may result in property damage, serious injury, and/or death. Never allow installation or use of this product by anyone without providing them with these instructions. You must read, understand and follow all instructions and warnings for any product(s) to which this product is used in conjunction with or installed. Save these instructions with the product for use as a reference for any future installation and use of the product.

WARNING

Failure to follow these warnings and instructions may result in property damage, serious bodily injury, and/or death.

- Purchaser/owner must ensure that product is installed according to these instructions. Purchaser/owner must not alter or modify the product.
- Operator and bystanders should never position any body part under any portion of this product or the load being supported.
- Do not allow children to play on or around this product or the load being supported.
- Weigh your trailer plus added load. Do not exceed the lesser of coupler, hitch, vehicle, ball, or trailer weight ratings (including load).
- Use only a 2 5/16" ball rated equal to or greater than the capacity of this coupler. Never exceed maximum rated capacity. Refer to stamped markings or decals on product to obtain rated capacity.
- Always secure load, vehicle and trailer (by blocking wheels) before latching/unlatching coupler.
- All hardware must be torqued to 125 ft. lbs. minimum. Periodically check for proper torque and tighten if necessary. Check for wear on inner tube if retightening is needed.
- If equipped with a load bearing pin, it must be fully inserted through both the inner and outer tubes in order for the coupler to support its rated load.
- Do not tow unless the load bearing pin is fully inserted and retaining pin is installed.
- Do not exceed the 8" maximum extension for this gooseneck coupler. Measure the coupler extension as the difference between fully retracted and fully extended positions. Couplers with properly installed load bearing pins and square adjustable gooseneck couplers only extend within this range.
- Keep the ball pocket, latch, and handle clean.
- All welding must be performed by an AWS certified welder.
- This product rated according to SAE J2638.

Before Towing:

- Check vehicle, hitch ball and coupler for signs of wear or damage. Ensure that the coupler opens, closes, and the handle springs closed when released.
- Always replace bent, broken, or worn parts before using this product.
- Ensure that the hitch ball is fully seated in the coupler ball pocket and the latch is closed.
- Make sure that the trailer safety chains are properly connected to the towing vehicle and trailer.
- Make sure that all trailer lighting is hooked up and working properly.

Installation Instructions

Warning: Failure to follow all installation instructions could result in coupler failure

Before mounting the coupler confirm that there will be no interference from the tow vehicle, tongue, ground, and any other mounted accessories while stationary or in motion. The set bolts(s) must be facing the towing vehicle. Before installing, check for interference in extended and retracted positions. Check for interference again after installation is complete. Weld size, gusseting requirements, coupler height, and orientation are dependant on trailer design and customer requirements, however, the outer tube must be supported completely by attaching gussets as low as possible to the outer tube. Avoid heat damage to coupler during welding, and do not weld over or near any holes or hardware on the coupler. All welding must be performed by an AWS certified welder. The outer tube must be rigidly attached to the trailer in order for the coupler to support its maximum rated load according to SAE J2638. Coupler must remain vertical after installation to ensure proper operation. After installation, check to make sure that coupler operation has not been impaired in any way. Do not use coupler if its operation has been impaired. After assembly and painting, but prior to being used, any enclosed labels must be affixed to the coupler and premask removed.

Gooseneck Coupler Installation Guidelines:

- 1) Be sure that the coupler will reach the towing vehicle to couple with the hitch ball while the load bearing pin is installed properly. The load bearing pin must be fully inserted through both the inner and outer tubes and the retaining pin installed in order for the coupler to support its rated load.
- 2) Tighten the set bolts and jam nuts to minimize vibrations in the coupler during towing. All hardware must be torqued to 125 ft. lbs. minimum.
- 3) Do not exceed 8" maximum extension from the couplers fully retracted position.

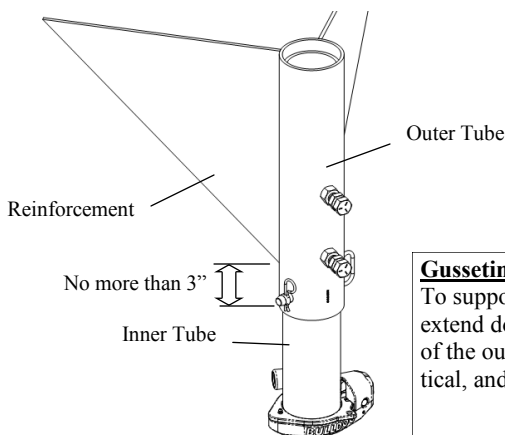

Gusseting:

To support the coupler's rated load, reinforcements must extend down the outer tube to within 3" above the bottom of the outer tube. The coupler must be held rigid and vertical, and must not be damaged by heat during installation.

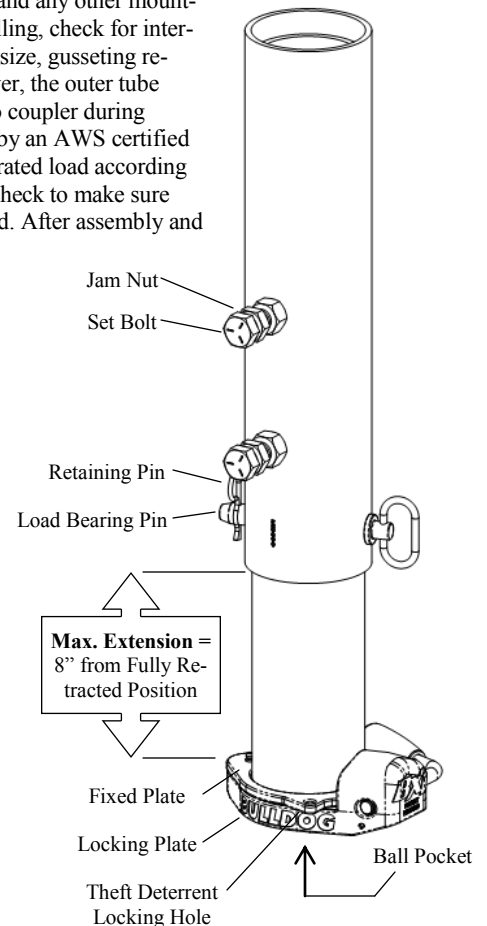

Operation

To Couple:

1. Block trailer wheels.
2. Align hitch ball beneath coupler.
3. Set coupler into the open position by lifting up on the handle and slide the locking plate into the detent.
4. Lower the trailer onto the hitch ball.
5. Visually check that the hitch ball is fully seated in the coupler.
6. Slide the locking plate over and place handle down into the closed position.
When using a recessed ball, check to make sure handle and locking plates are clear of any interference with safety chains and D-rings.
7. Insert (optional) theft deterrent lock through hole in fixed plate.

To Uncouple:

1. Block trailer wheels.
2. Remove lock (if equipped) and set the handle into the open position.
3. Slide the locking plate into the open position and raise the trailer from the hitch ball.

Locking plate

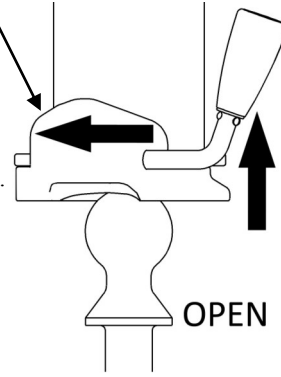

Open Position - **DO NOT TOW!**

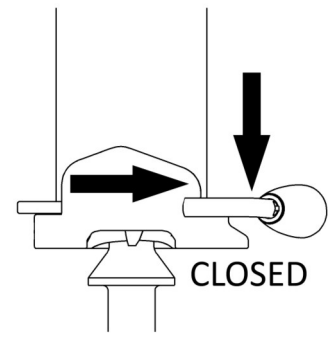

Closed Position - **OK to tow**

Maintenance

Keep ball pocket and mechanism clean. The following procedures should be performed at least annually:

- Check hardware torque
- Grease all fittings & ball pocket
- Inspect retaining pin; replace if necessary

Available Parts Kit

A Handle repair kit is available to replace worn or malfunctioning parts. This kit includes the Handle assembly, Locking cam, Groove pin, Bushing and Torsion spring. Required tools = hammer and 5/32" punch. To install;

1. Loosen set bolts, remove load bearing pin and lower coupler assembly from trailer. With ball pocket facing up (Fig. 1), take visual note of the parts and their orientation, paying particular attention to the function of the handle and locking cam. Rotate handle exposing the groove pin. With a punch, remove the groove pin and slide handle from the coupler. Remove and discard all old parts. **DO NOT** reassemble using any previously existing parts—only use components supplied within the parts kit.
2. Place bushing within coupler body. Assemble the straight leg side of the torsion spring into the locking cam and lower into the casting. Be certain the cam lobe notch rests against inside edge of the coupler casting (Fig. 2). Next, insert the bent-leg end of the spring into bushing side of casting and slide the handle through the assembled parts. Lastly, align the hole in the handle with hole in cam, and fix groove pin into place. A properly assembled handle

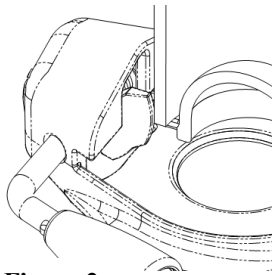

Figure 2

will make a loud “clack” from an open to a closed position when the locking cam hits against the coupler casting.

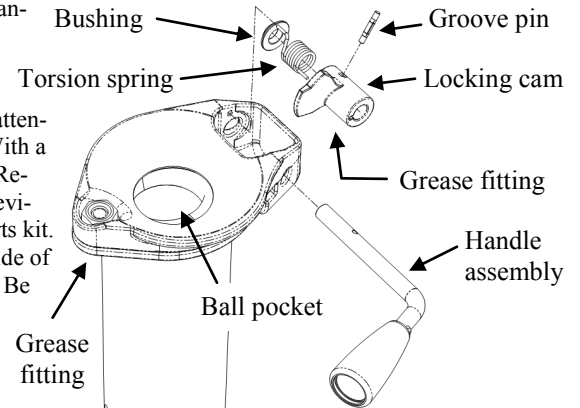

Figure 1