

# HTVANRK

## Multi-Use Van Rack

### Assembly & Operating Instructions



READ ALL INSTRUCTIONS AND WARNINGS BEFORE USING THIS PRODUCT.

This manual provides important information on proper operation and maintenance. Every effort has been made to ensure the accuracy of this manual. We reserve the right to change this product at any time without prior notice.

**STOP! DO NOT RETURN THIS PRODUCT TO THE RETAILER.**

Multi-Use Van Rack HTVANRK Assembly and Operating Instructions

HTVANRK Adjusts From 56" to 77" Wide, and adjusts From 6 1/4" to 8 1/2" High

Verify that you have received the hardware and parts in the correct quantities as shown below.

**Hardware**

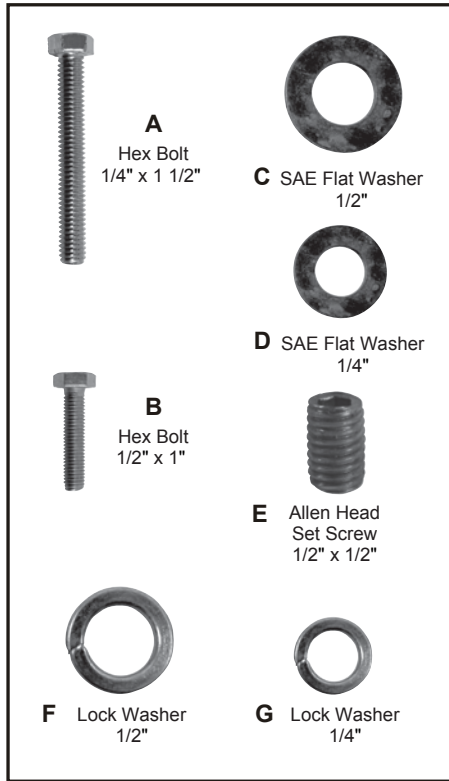

**Parts**

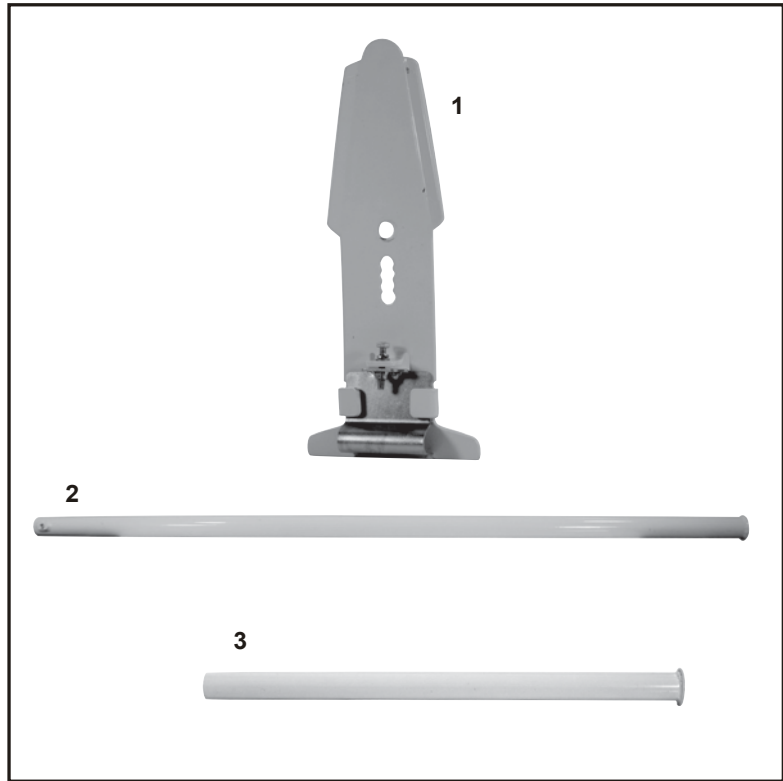

**Hardware List**

Item No.	Description	Quantity	Remarks
A	Hex Bolt: 1/4" x 1 1/2"	4	
B	Hex Bolt: 1/2" x 1 1/2"	4	
C	SAE Flat Washer: 1/2"	4	
D	SAE Flat Washer: 1/4"	4	
E	Allen Head Set Screw: 1/2" x 1/2"	2	
F	Lock Washer: 1/2"	4	
G	Lock Washer: 1/4"	4	

Note: A Wrench and an Allen Wrench (not included) are tools required for installation.

**Parts List**

Item No.	Description	Quantity	Remarks
1	Upright	4	
2	Long Crossbrace	2	
3	Short Crossbrace	2	

## Step 1

Select the Upright Mounting Hole that matches the roof top of the van. (FIG 1)

Insert Hex Bolt (B), Lock Washer (F), & SAE Flat Washer (C) into Mounting Hole and thread through the Short Crossbrace (FIG 2). Insert the Short Crossbrace into the Long Crossbrace (FIG 3). Insert the Set Screw (E) but don't tighten. Add the remaining Upright to complete the first crossbrace.

Repeat Step 1 to complete the second and final crossbrace.

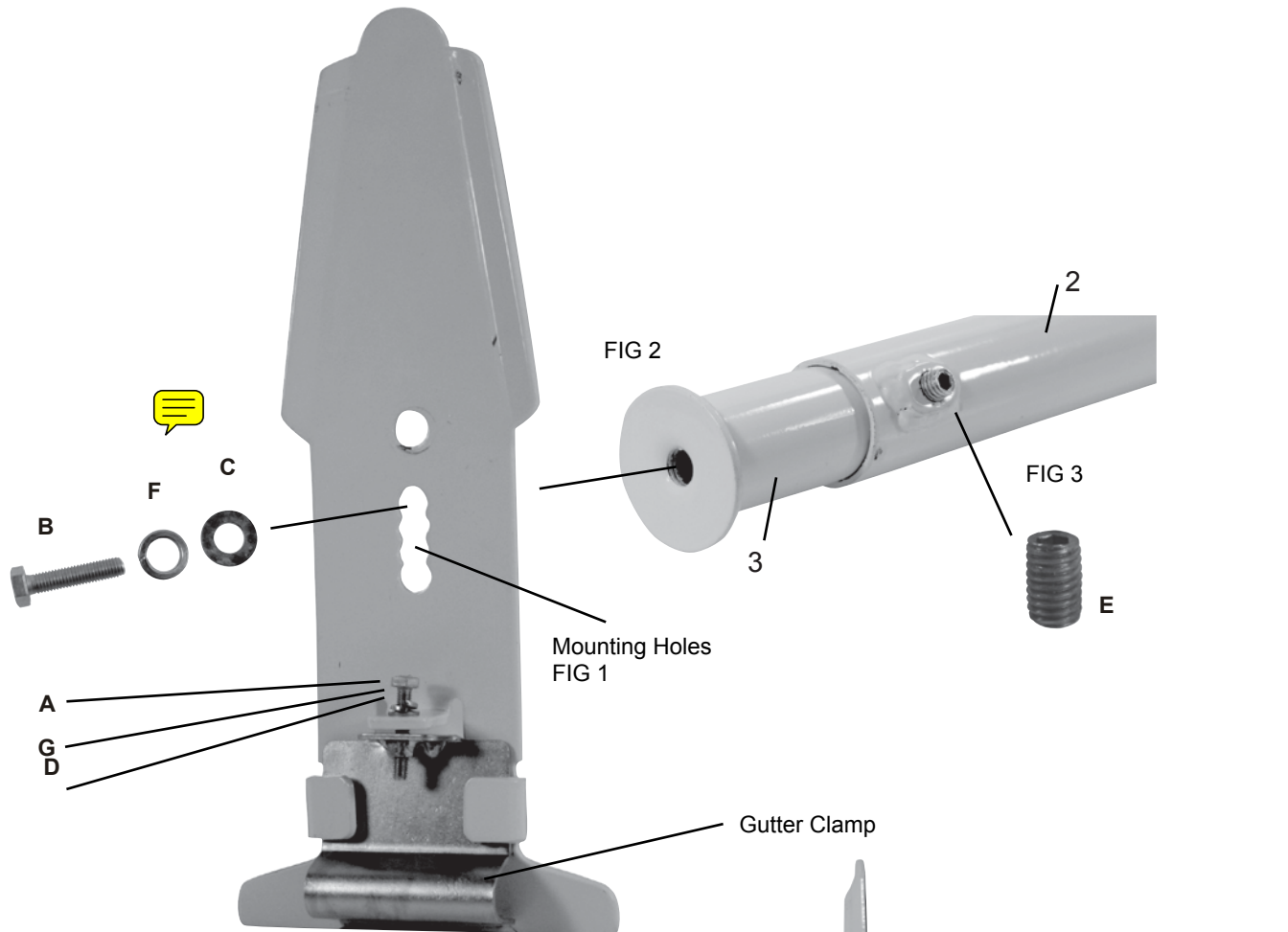

## Step 2

Place the completed crossbraces on top of the van and adjust for proper width. Proceed to tighten the Set Screw (E). Adjust the Gutter Clamp around the van's rain gutter (FIG 4) and tighten with Bolt (A), Lock Washers (G) and Flat Washers (D).

The Multi-Use Van Rack is now ready for use.

Note: Move the crossbrace to eliminate wind noise.

**WARNING: DO NOT EXCEED 500 LB. LOAD CAPACITY.**

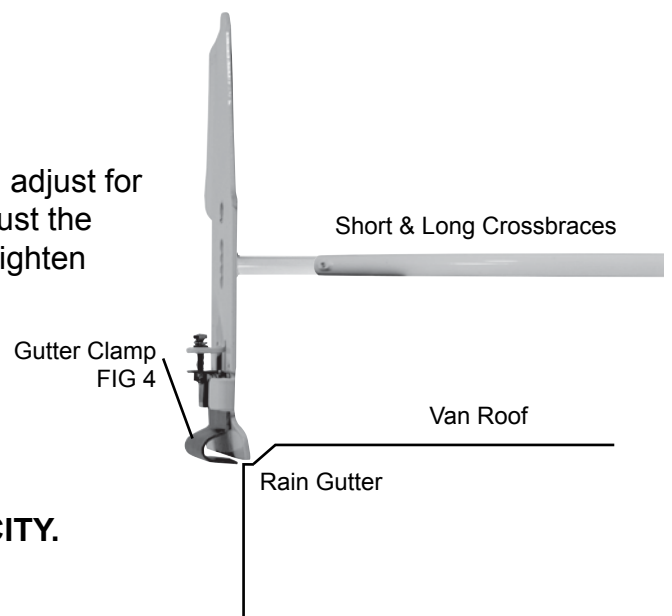

[View other commercial van equipment made by Buffalo Corporation on our website.](#)