



Installation Instructions
Part number 1094XX Frameless Soft Top
for
Jeep® Wrangler YJ 1992-1995
with Half Doors

NOTE: Installation of the top in warm weather is optimal for ease of installation. Ideal installation temperature should not be less than 70° (21C). Initial installation is the most difficult as the fabric has not been stretched. The top will loosen slightly with use and warm temperature. Allow about at least an hour for the initial installation.

*****Please follow instructions for ease of installation and correct fit.*****

Included:

- 1 x Top components (Top, side windows, Rear window, window storage bag, Door skins)
- 1 x Left Door surround assembly
- 1 x Right Door surround assembly
- 2 x Roll bar clamps w/Hex head bolts

Required Tools:

- 1/2" or 13mm combination wrench or socket.
- Phillips screw driver.

- Step 1.** Remove existing soft top. For OEM (original/factory) soft tops: remove header bar, remove tube frame hardware from roll bar, and remove the rear window/tailgate bar and set it aside for the new top. Keep the rear bar mounting hardware in place on the body as the rear bar will be re-used.
- Step 2.** Install a Rampage Windshield Channel per installation instructions.
- Step 3.** Use the included hardware to attach the clamp to the folding door surrounds. Look for the hole on the top section near the pivot, the clamp installs on the opposite side from the snaps. The knob installs from the top.
- Step 4.** Install the door surrounds by sliding the lower mount into the factory rail on the vehicle and inserting the windshield pin in place on the windshield upright. Loosen the clamp, place it so it is on the roll bar and then tighten. See Figure 0.
- Step 5.** Unfold your new Soft Top, set the windows aside for later use, taking care not to scratch windows. Place the top on the center of the roll bar and unfold. Spread the top out and taking care that the metal flat hooks at the end of the rear adjustment straps *do not damage paint, glass or cause injury*. See Figure 1.

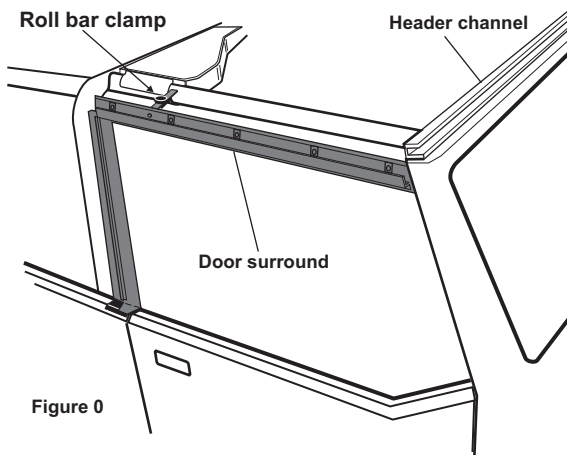

Figure 0

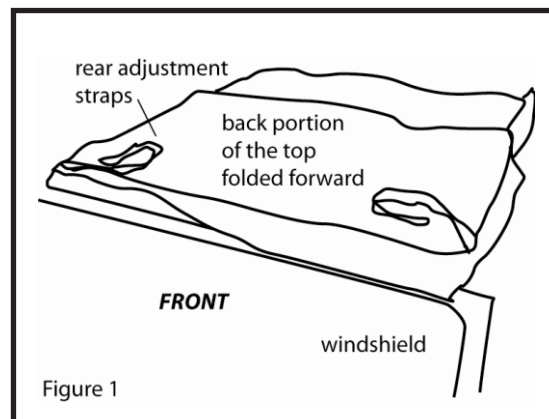

Figure 1

- Step 6.** This will center the top at the front. At the same time check that the front plastic is near the front of the windshield Channel.

Step 7. Insert front plastic into the groove of the Windshield Channel. The ends will match nearly to each end of the Windshield Channel. From the front of the vehicle, check to make sure that the top is even from side to side. Check the door surround sides and push the top towards the rear to make sure the fabric is seated tightly around the front corners. Now snap the front snaps on the door surrounds. See Figure 2.

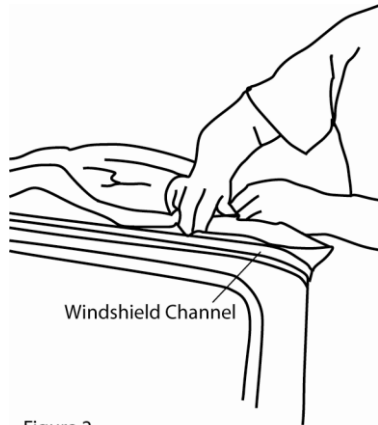

Figure 2

NOTE: If you have difficulty putting the plastic strip into the channel, try hooking the strap from the soundbar/roll bar to the footman loop first. This will give some tension across the channel and help keep the front of the top in place.

Step 8. Sitting in either front seat; find the center adjustment strap near the roll bar. Pull the strap around the back of the rollbar then toward the front. Thread the webbing through the factory footman loop above the windshield and tighten snug at the strap adjuster. Tighten snugly so there is some tension on this strap.
NOTE: So as not to over tighten, do not use any tools to tighten this strap. See Figure 3 & 4.

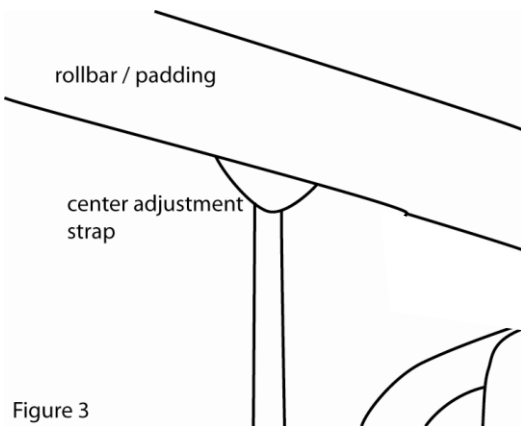

Figure 3

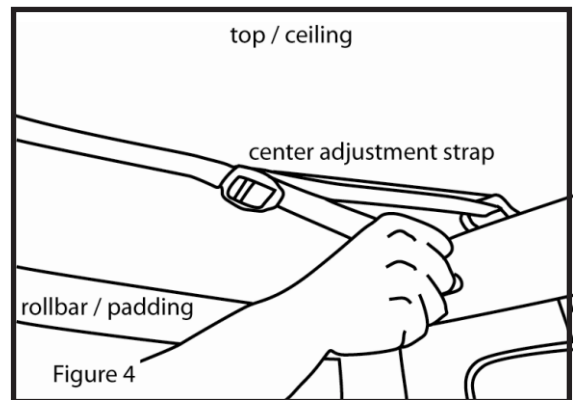

Figure 4

Step 9. Locate the ceiling adjustment straps (at rear corners on ceiling panel). Gently pull the strap over the rollbar, and around the seatbelt stud (toward the inside) and back up to the strap adjustment buckle. Tighten snug, and perform same procedure on the other side. Check top for evenness from side to side. See Figures 5, 6, 7, & 8.

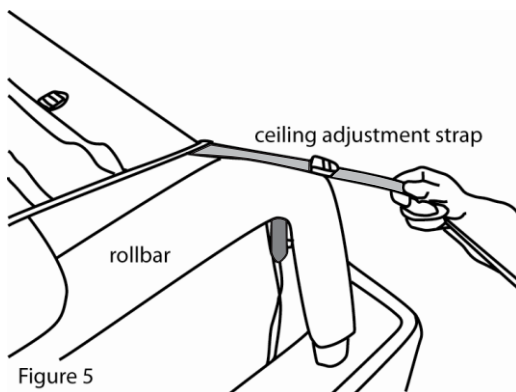

Figure 5

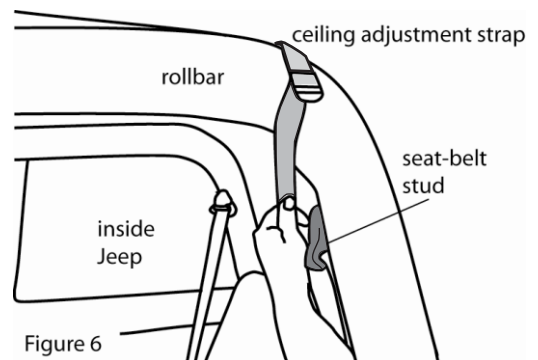
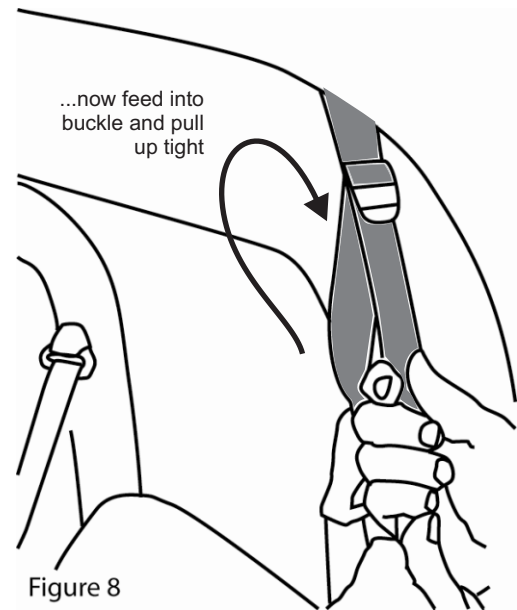
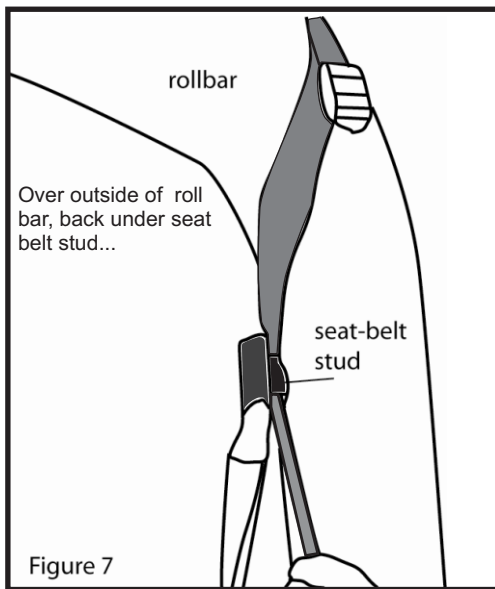

Figure 6



- Step 10.** Install the side windows by mating the zippers. Loosely attach the rear window to the three straps on top rear. Mate the rear window zippers to the top on both sides and zip the sliders down about 6”.
- Step 11.** Continue attaching the Belt Rail plastic of the side windows from front to back, starting on the back top of the door surrounds. Hook the Belt Rail plastic to the back section of the door surround.
- Step 12.** Prior to continuing; make sure rear door zippers have been started on both sides. Set the Belt Rail plastic even with the factory weather strip at the body gutter – directly behind the door. Continue fastening the plastic under the Belt Rail lip of the body until the top is fully attached around the back corners of the body.
- Step 13.** Slide rear bar into the tube plastic on the bottom of the rear window. Insert the Tailgate Bar into the side clips, check for evenness from side to side. Rotate the bar towards the inside to lock it in place same as the factory installation. Zip the rear window and pull the Hook and Loop a.k.a. “Velcro” closed.
- Step 14.** On top of the rear part of the roll bar pull the side to side adjustment straps snug, do not over tighten. Pull the three rear window straps snug.
- Step 15.** Pull the roof top down. Handle the metal hooks on the end of the straps with care to avoid damage or injury. Attach the flat hooks under the Belt Rail at the reinforced patches on each side of tailgate, and pull the straps down snug (WITH ONE HAND, NO TOOLS). While holding the straps in-line and secured to the hook and loop, close the cam buckle into the locked position.

The Front Bow inserts

The fiberglass bows in the front section of the top are intended primarily to keep water from pooling on the front section of the top in heavy rains. Without the bows it is possible for water to pool in the front section of the top and cause issues with the seams because of the weight. They will also keep the top from fluttering if it is installed properly. The bows are easily removed by flexing the inner rod and removing from the pockets. The top will function normally without them, however it is recommended they be used in heavy rains when parked.

Rear window bows

The fiberglass bows in the rear side windows are included to keep tension on the rear panels and improve fit. The front portion should rest on the door surround and the rear against the rear roll bar.

Storing Windows

To store your windows, begin by removing the hooks from the rear Belt Rail and flipping the top to expose the storage bag. Again, take care *not* to fling the top to avoid metal hooks causing damage or injury. Remove the windows and store them in the bag utilizing the window separation panels to protect the window.

Door Skin Installation

Step 1. After removing skins from packaging, leave the Door Skins out in the sunlight for at least 1 hour.



Step 2. Unzip the Door Skin Window.

Step 3. Insert the frame into the upper rear corner of the door skin and then insert the Frame into the upper front corner of the Door Skin. Press down the Velcro to secure the frame bar.

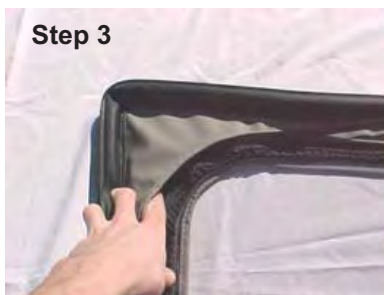

Step 4. Insert the lower front corner of the Frame into the Door Skin (tight fit).



Step 5. Wrap the Velcro around the Frame that runs the length of the bottom and secure.

Step 6. Make sure the three legs of the Frame are seated in the 3 cut-away parts of the Door Skin. Close the 2 large and 1 small flaps on the bottom of the Door Skin. Door Skin is now assembled.

Important Care Instructions:

Convertible tops and accessories require special care if you want to get the maximum usage and enjoyment from them. The following recommendations, if followed carefully, can extend the life of your top or accessory.

Hand wash using a mild non-detergent soap such as ivory. Use a non-abrasive cloth or sponge. Rinse thoroughly.

Do not wash in direct sunlight and avoid automatic car washes

When your top is clean, we recommend using "Ragg Topp" or "303 Protectant" on both the vinyl top and windows. This product contains a sunscreen that helps protect from the sun's damaging rays. Stay away from products containing alcohol, as it will cause the fabric and windows to lose their elasticity, thus reducing the life of your top or accessory.

Direct sunlight and heat are the biggest enemies of the windows. Park in the shade whenever possible. If you must park in the sunlight, rotate the direction that you park every few days so all windows get even exposure.

Our tops are designed so that you may roll up and/or store the rear curtain and side curtains. To prevent scratching of the windows, be sure that windows are completely clean and free of dust particles. Even a little dirt will badly scratch the windows. You may want to use a soft cloth when rolling up or storing your windows. Heat may build up on rolled up windows, so be sure to unroll them frequently. If you roll up the windows at the beginning of summer and leave them, they may be ruined by fall.

Do not open or roll up windows at temperatures below 45 degrees F this could cause them to crack or break.

Zipper Care.

DO NOT use pliers or other tools to pull on zippers. If the zipper requires more force than pulling with your fingers something is most likely out of alignment or improperly installed. Be sure the top is up to a temperature of 70 deg., and that the components are installed correctly and in the correct sequence to ensure protection of the zipper.

Zippers require periodic cleaning and lubrication to ensure longevity and ease of use. Clean by wiping with a towel soaked in soap and water, DO NOT USE HARSH CHEMICALS. Zipper lubricants are available at sporting goods stores and online for wetsuits. An occasional use will keep the zipper slides operating as new.

Warranty Information

Rampage products, Inc. warrants to the original purchaser of any top it manufactures, that the top will be free of defects in material or workmanship for a period of 2 year from date of purchase. Such obligations under this warranty shall be limited to the repair or replacement, at Rampage products discretion, of any assembly or parts which, upon examination by Rampage products, Inc. proves to be defective. All defective items must be returned with proof of purchase to Rampage products, Inc., freight prepaid. This warranty does not cover damage resulting from abuse, misuse, alteration, accident or damage in transit. Rampage products obligations under this warranty are limited to the aforementioned repair or replacement of warranty defects for which the return authorization has been received during the warranty period, and Rampage products, Inc. shall not be liable for any incidental or consequential damages arising from breach of this or any implied warranty.