

## Rear Parking Assist System

### User's Manual

Thank you for choosing BOYO

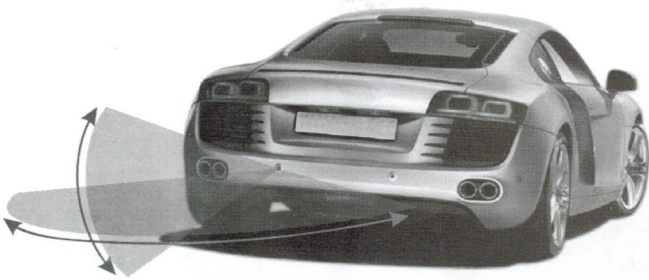

Take the time to read through this instruction manual. Familiarity with installation and operation procedures will help you obtain the best performance from your new Video Parking Sensor.

For your records: Record the serial number, found on the back of the unit, in the spaces designated on the warranty card.

Refer to the model and serial numbers whenever you call upon your BOYO dealer for information or service on the product.

Please note that all specifications and information contained herein are subject to change without prior notice.

Any changes will be integrated into the latest release. The manufacturer assumes no responsibility for any errors or omissions in this document.

#### Accessories

1. 22.9ft Buzzer cable x1
2. Control Box x1
3. 8.2ft Waterproof sensor x4
4. Power Cable x1
5. Sensor Drill x1
6. Double-Sided Tape x2
7. Warranty card, Registration Card, User's Manual

1

#### Key Features

- 4 rear parking sensors with waterproof connector
- Audible Buzzer with volume adjustment (Off, Low, High)
- Detective distance from 1.0ft to 5.9ft
- Include Metal Bumper Hole Saw
- Can be used with any aftermarket monitor and camera that uses standard RCA video plugs
- Distance readings are shown on monitor

#### Technical Data

Parking Sensor	Rated Voltage	DC12V
	Operating Range	DC9-16V
	Rated Current	20mA-200mA
	Detective Distance	1.0-5.9ft
	Ultrasonic Frequency	40KHZ
	Working Temperature	-22°F ~176°F

#### Sensing Characteristics

Stage	Condition	Distance	Audible Alarm
1	Safe Mode	4.9-5.9ft	Bi.....Bi.....
2	Alarm Mode	3.6-4.6ft	Bi.....Bi.....
3		3.3ft	Bi.....Bi.....
4		3.0ft	Bi.....Bi.....
5		2.6ft	Bi.....Bi.....
6	Danger Mode	2.3ft	Bi...Bi...
7		2.0ft	Bi...Bi...
8		1.6ft	Bi..Bi..
9		1.3ft	Bi..Bi..
10		0-1.0ft	Biii

#### Installation Instruction:



**Note:** Before installing system let the components of the exhaust system cool down. This will make the installation safer and preclude heat damage to the system wiring or components.

The following illustration shows the general location of the components of the system.

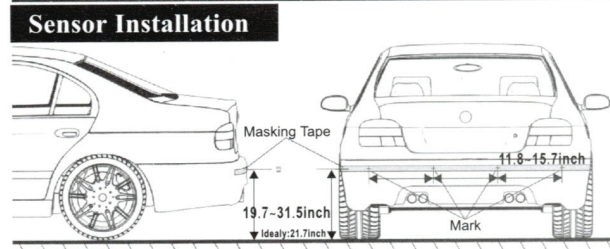
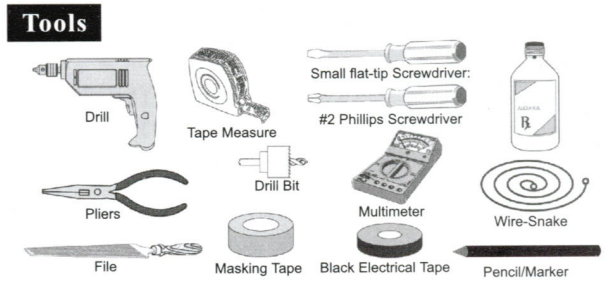
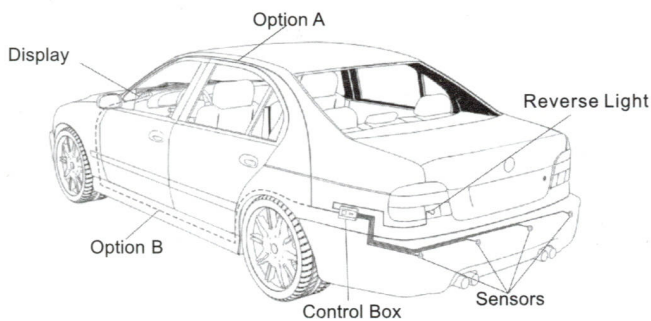

First locate where you are going to install the sensors and place a piece of masking tape. Measure and mark the positions of the holes.

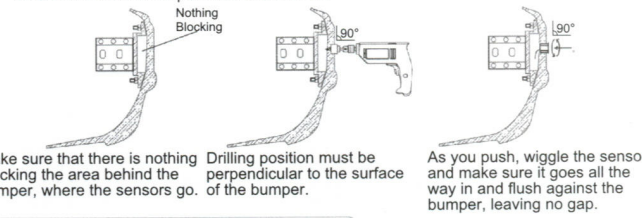

Make sure that there is nothing blocking the area behind the sensors go. Drilling position must be perpendicular to the surface of the bumper. As you push, wiggle the sensor and make sure it goes all the way in and flush against the bumper, leaving no gap.

Install the sensors vertically; the "UP" sign must be on upside.

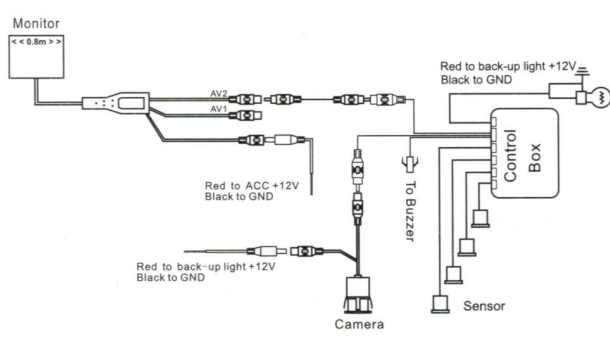

### Control Box Installation

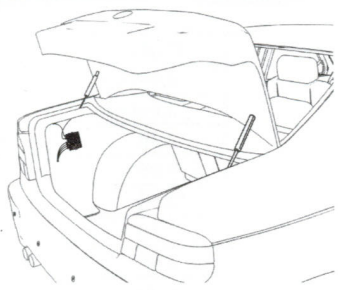

Remove the necessary back panels to mount the control box in a safe place, away from rain, heat or humidity.

### Test After Installation

Follow below steps to test and verify the operation of the system:

**Warning:** Do not stand behind a moving vehicle, death or injury may occur. Prior to testing, set the parking brake On, ignition key On (do not start), step foot on brake and shift the vehicle into reverse. Ensure that the engine is not running while proceeding with the following tests.

Test the system operation with a piece of wood (23.6\*11.8\*0.4inch) or other object (not too small) after the installation. Start with the wood more than 3.28ft away from the vehicle. Then move the wood closer the vehicle and ensure that the buzzer, LED, and distance indicators display correctly.

### Limitations

The sensors may not work if an object does not reflect the ultrasonic waves or it has an unusual shape, pole, cardboard carton, tire of bicycle, small or slender tree, rectangular lumber or curbs tone. The sensor may not detect another vehicle bumper if it is too high. Also note: This system has different detection distance to the different object. To the wall, the max detection distance is 1.8m; to the human body, the max detection distance is 1.0m; to the column is 0.40cm, the max detection distance is 1.2m.

In some special cases, the display may not be the same as the real condition due to the sensor position, obstacle shape, reflection condition and so on. Some examples are given below

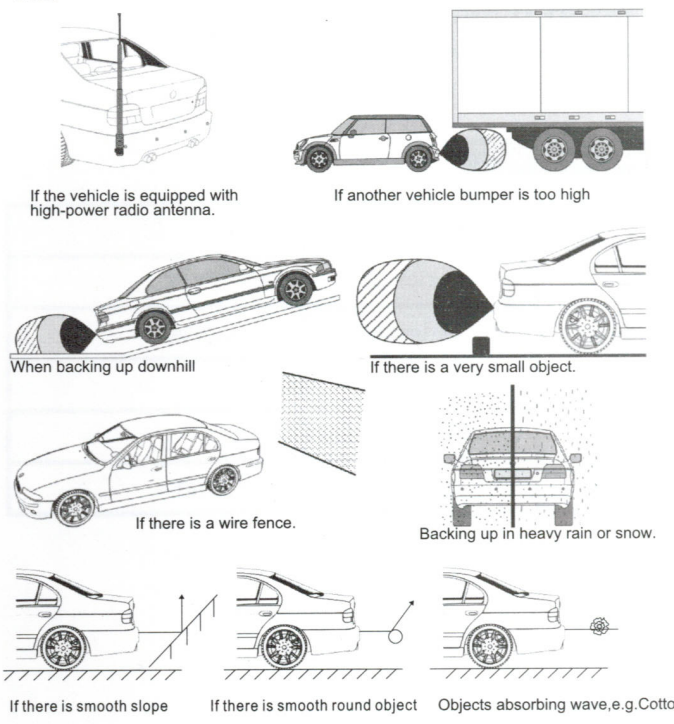

Find out more about cameras and driver safety we have.