

INSTALLATION INSTRUCTIONS



BOSCH

GENERAL MOUNTING INSTRUCTIONS

The manufacturer produces a full line of gauges with many different styles.

- 1-1/2" Gauges
- 2" Gauges
- 2-5/8" Gauges

Gauges allow you to monitor the condition of your vehicle and tell how well it is performing. If there are any problems, you can detect them immediately before they become severe. Warning lights only tell you when the problem already requires immediate attention. You will find that the addition of these gauges will add to your peace of mind and driving comfort.

MICROPROCESSOR-CONTROLLED ENGINES

Many newer vehicles employ microprocessors that control most of the engine and electrical functions. Microprocessors are very sensitive electrical components. Before installing any aftermarket equipment consult the vehicle's manufacturer or shop manual to make certain that no damage will result.

Some of these newer vehicles use electric cooling fans or microprocessor engine controls that depend on readings from the original equipment

sending units for correct operation. If your vehicle is one of these you CANNOT replace the sender(s) with any other. You can add an additional oil pressure sender with a "Tee Adapter Kit," but the only possible way to install a non OEM water temperature sender is to install the new sender in a different location, retaining the OEM unit in its original location. Check with the vehicle's manufacturer or dealer to see if this is possible.

INSTALLATION & SAFETY PRECAUTIONS

1. Read the entire instructions for your gauge before proceeding.
2. Be sure the gauge is suitable for your vehicle:
 - Does the gauge's range cover the vehicle's operating range?
 - Will the tubing of the mechanical gauges reach from the engine connection point to the gauge (temperature gauges cannot be lengthened)?
 - Is the vehicle's electrical system 12 volt and negatively grounded?
3. It is recommended that the battery ground cable be disconnected before any electrical work is performed, especially when installing Ammeters or Voltmeters.
4. Route all wiring and gauge tubing away from linkages, high heat or moving parts.
5. Never smoke while working on your vehicle and always keep a fire extinguisher nearby. It should be rated for gas/chemical/electrical fires.
6. Never lay tools on top of the battery or wear jewelry during electrical work to avoid severe electrical shorts.

GAUGE MOUNTING

All gauges can be mounted into a surface of your choice or into a panel. Single, dual & triple gauge mounting panels are produced for all size gauges. Some panels are in black or chrome finishes. A fully chromed mounting cup is available for the 2-5/8" gauges.

1. Choose a location to mount the gauge where it will be viewable from a normal driving position (fuel pressure gauges should never be mounted within the interior of the vehicle).
2. If you are using a mounting panel, mount it at the chosen location with the screws provided.

If you are creating a hole, use the following sizes:

Gauge Style	Hole Size
1-1/2"	1-5/8" (41 mm)
2"	2-1/16" (53 mm)
2-5/8"	2-5/8" (67 mm)

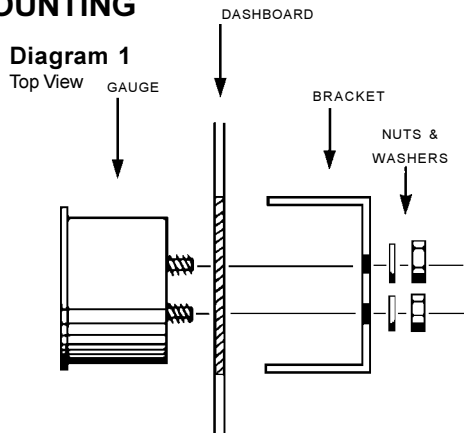

3. Dimmer Control.

For dash lighting dimmers that control the positive side (Diagram 2A) of the lighting circuit:

Diagram 2A

For Positive Dimmer Controls

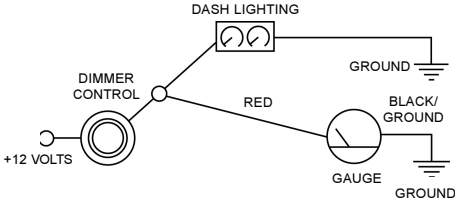

- For Two-wire Bulb Holder -

Connect the red wire into the circuit between the dimmer control and the dash lights. Connect the black wire to a good electrical ground.

- For One-wire Bulb Holder -

Connect the one wire into the circuit between the dimmer control and the dash lights. Obtain a length of 18-gauge insulated copper wire and connect one end of the wire to a good electrical ground source and the other end to one of the mounting bracket posts.

For dash lighting dimmers that control the grounded side (Diagram 2B) of the lighting circuit:

Diagram 2B

For Ground Dimmer Controls

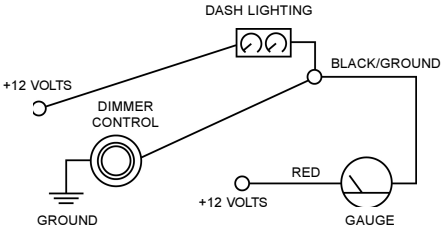

- For Two-wire Bulb Holder -

Connect the black wire into the circuit between the dimmer control and the dash lights. Connect the red wire to the fuse box so that the wire only receives +12-volt power when the dash lights are turned on.

- For One-wire Bulb Holder -

Connect the wire to the fuse box so it receives only +12-volt power when the dash lights are on. Obtain a length of 18-gauge insulated copper wire and connect one end to the gauge mounting bracket or panel. Connect the other end of the wire into the circuit between the dimmer control and the dash lights. **Insulate the gauge and bracket from grounded surfaces.**

4. Refer to specific instructions for the gauge you are installing. They explain other connections that should be made before mounting is completed.
5. Insert the gauge into the mounting panel or hole.
6. Insert the bulb holder into the bulb socket on the back of the gauge.
7. Install the appropriate mounting bracket (Diagram 1: insulated or non-insulated) over the mounting posts (Diagram 3), slide on washer, plus a lock washer if supplied, and tighten the nut with only light pressure. If the gauge is an electrical model, be sure you use a bracket that has grommets to insulate the posts from the mounting bracket. This does not apply to gauges using separate bracket mounting posts from the posts used for wire connections.
8. Position the gauge for best visibility and appearance, then tighten the bracket nuts with moderate pressure. Do not over-tighten these nuts when using an insulated bracket. Excess pressure can distort the grommets causing them to crack and short the wiring, even months after installation.
9. Refer to the specific instructions for the gauge you are now installing to complete any other connections.

Diagram 3

Electrical Gauges Shown

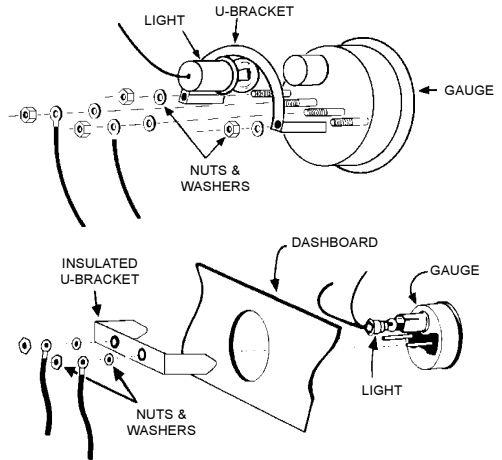

WATER/OIL TEMPERATURE GAUGE INSTRUCTIONS

Warning: If your car is microprocessor (computer) controlled or has an electric cooling fan, refer to the section in the installation instructions titled "Microprocessor Controlled Engines."

Temperature gauges measure the temperature of any liquid their sender tip is submerged in. An electrical temperature gauge is simpler and more versatile for installation than a mechanical gauge but is not quite as fast to respond to temperature changes.

PRECAUTIONS

1. A temperature gauge requires that its sender tip have a circulating flow around it to give an accurate reading. For this reason, a T-fitting cannot be used because it has no circulation therefore the original warning light sender cannot be operated off the same location. An additional location may be available on the cylinder head, intake manifold, or thermostat housing but caution should be used in that these locations may have different average temperatures than the original warning light sender location.
2. Do not over tighten the fittings or sender, particularly for mechanical gauges. The threads are designed to strip before the engine component can be damaged. The fittings use tapered self-sealing threads and do not require extreme force to seal properly.
3. Do not use sealing tapes or compounds on electrical senders as this will disturb their grounding connection to the engine resulting in false low readings.
4. Take caution when uncoiling and routing the mechanical gauge's capillary tubing that you do not bend it too sharply or flex it too often. Any break in the inner tube will make the gauge nonrepairable. A replacement service is available only at the factory service center.
5. Always install the adapter fitting into the engine first and then tighten the captive fitting (Diagram 1) on the capillary tube to avoid twisting the tubing.

6. Never install the captive fitting on the capillary tube directly into the engine without an adapter, as a proper seal will not be formed.

INSTALLATION

Note: If you are planning to use both an oil temperature gauge and an oil pressure gauge, some modifications may be necessary as there is only one available hole for both senders. Since the temperature gauge cannot use a T-fitting, we suggest that you install the oil temperature sender into the oil pressure warning light sender location in the engine block. Then obtain an adapter (which we do not manufacture) used for oil coolers which will give you an additional outlet for oil pressure.

FOR MECHANICAL GAUGES:

1. Drain the fluid level in the system to below the sender's mounting location which is normally the factory's warning light sender location.
2. Route the capillary tubing through the mounting

Diagram 1

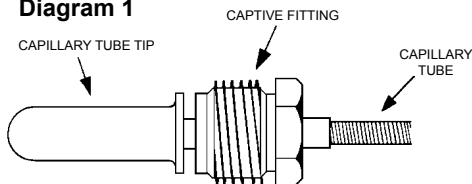

hole for the gauge and then through the firewall, protecting the tubing from rough edges. Form at least one 3" or larger loop of tubing as it comes through the firewall and route the remainder to the sender mounting locations.

- Remove the warning light sender and install the proper adapter fitting into the engine block. If the proper adapter fitting was not included with the gauge, obtain the CP7555 (NPT threads) adapter set.
- Insert the capillary tube tip into the adapter's hole and then tighten, with moderate pressure only, the captive fitting (Diagram 1) into the adapter. Do not over tighten. Sealing tape or compound may be used on either connection.
- Complete the mounting of the gauge.
- Refill the fluid level to its normal level.
- Start the engine and observe the fitting connections for leaks and the gauge for proper operation.
- Connect one end of another length of 18-gauge insulated copper wire to the center connection post, as shown in Diagram 2 and the other end of the wire to a good ground source.
- Connect a third length of 18-gauge insulated copper wire to the right connection post as shown in Diagram 2, and the other end of the wire should be connected to the fuse box where the wires will receive +12 volts of power whenever the ignition key is in a START, ON or ACCESSORY position.
- Refill the fluid level to its normal level.
- Start the engine and observe the fitting/sender connections for leaks and the gauge for proper operation.

FOR ELECTRICAL GAUGES:

- Drain the fluid level in the system to below the sender's mounting location, which is normally the factory's warning light sender location.
- Remove the warning light sender and insulate the end of the sender wire. Install the proper adapter fitting (not included) into the engine block, if needed. Obtain either the CP7553 (NPT threads) or CP7573 (metric threads) adapter set, if an adapter is needed.
- Install the gauge's sender into the warning light sender's mounting location in the engine block.
- Run a length of 18-gauge insulated copper wire from the gauge's mounting location to the sender's mounting location.
- Attach the 18-gauge wire onto the top of the gauge's sender.
- Facing the back of the gauge, the connection post on the right is for the +12-volt power, the center post is for the ground connection and the left post is for the sender connection. After you have mounted the gauge, connect the sender

TROUBLESHOOTING

If your electrical gauge reads lower than you would expect, check all electrical connections, particularly grounding connections. Any poor connection will increase electrical resistance resulting in a false low reading.

Diagram 2

