

Chevrolet Camaro (Gen6) Installation Guide

PN– 11920, 11921, 11924, 11925, 11926, 11927, 11930, 11931



Thank you for purchasing a Borla [Performance Exhaust System](#).

Borla Performance Exhaust Systems (PNs 11920, 11921, 11924, 11925) are designed for the Chevrolet Camaro 6.2L V8 engine with manual or automatic transmissions.

Borla Performance Exhaust Systems (PNs 11926, 11927, 11930, 11931) are designed for the Chevrolet Camaro 3.6L V6 engine with manual or automatic transmissions.

System installation requires cutting stock exhaust tubing.

Borla Performance Industries recommends that an exhaust shop or professional after market parts installer, who has all the necessary equipment, tools and experienced personnel needed for proper installation, should perform the installation of this system. However, if you decide to perform the installation, we recommend someone should help you. Ensure the installer uses all under car safety precautions including eye protection.

Please take time to read and understand the following...

By installing your Borla Performance Exhaust System, you indicate that you have read this document and you agree with the terms stated below.

It is the responsibility of the purchaser to follow all installation instruction guidelines and safety procedures supplied with your Borla Performance Exhaust System.

Borla Performance Industries assumes no responsibility for damages occurring from misuse, abuse, improper installation, improper operation, lack of responsible care, or all previously stated reasons resulting from incompatibility with other manufacturer's products and/or systems.

Included with your Borla Performance Exhaust System is a warranty card. Please read it carefully before you begin any work on your vehicle. If you should have any questions regarding our warranty policy, installation, or any other matter pertaining to your new Borla Performance Exhaust System, please give us a call at the number provided on the warranty card.

Minimum Required Tool List:

TOOLS:

1. 3/8” Drive Ratchet
2. 3/8” Drive Extension 9”
3. 15mm Socket
4. 15mm Wrench
5. 14mm Socket
6. 14mm Wrench
7. Pry Bar

SHOP SUPPLIES:

- 1 Spray Lubricant

Borla Performance - Bill of Materials

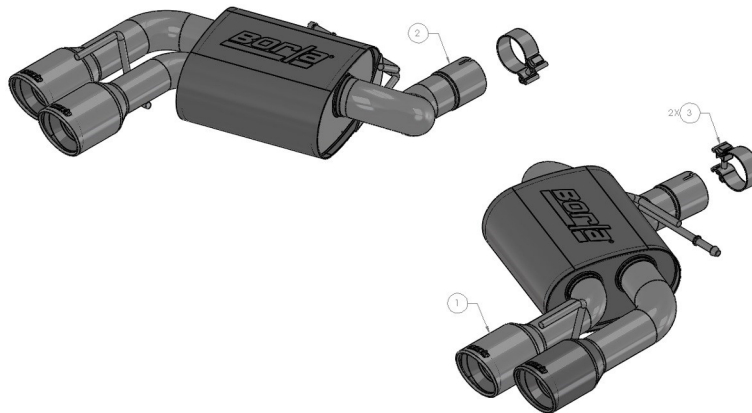

11920

ITEM NO.	QTY.	PART NUMBER	DESCRIPTION
1	1	55938	R/H MUFFLER ASSEMBLY
2	1	55939	L/H MUFFLER ASSEMBLY
3	2	90116	S/S ACCUSEAL CLAMP: Ø2.75

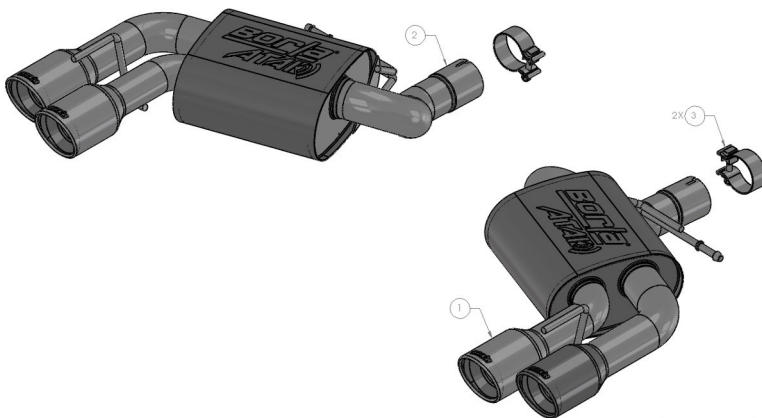

11921

ITEM NO.	QTY.	PART NUMBER	DESCRIPTION
1	1	55932	R/H MUFFLER ASSEMBLY
2	1	55933	L/H MUFFLER ASSEMBLY
3	2	90116	S/S ACCUSEAL CLAMP: Ø2.75

Minimum Required Tool List:

TOOLS:

1. 3/8" Drive Ratchet
2. 3/8" Drive Extension 9"
3. 15mm Socket
4. 15mm Wrench
5. 14mm Socket
6. 14mm Wrench
7. Pry Bar

SHOP SUPPLIES:

- 1 Spray Lubricant

Borla Performance - Bill of Materials

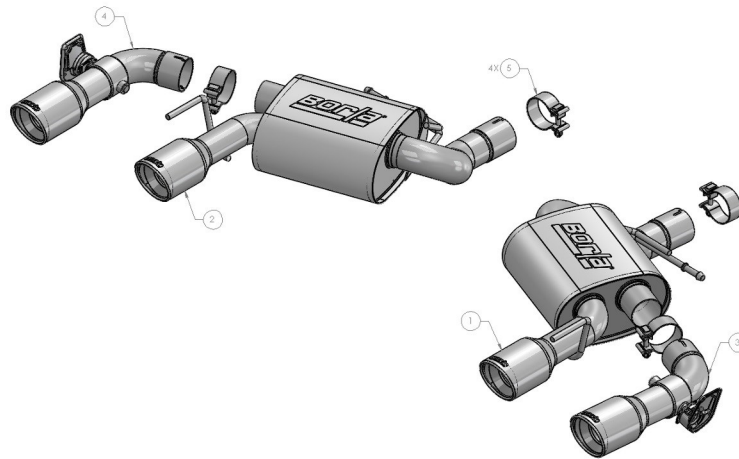

11924

ITEM NO.	QTY.	PART NUMBER	DESCRIPTION
1	1	55979	R/H MUFFLER ASSEMBLY
2	1	55980	L/H MUFFLER ASSEMBLY
3	1	55952	R/H TAILPIPE ASSEMBLY
4	1	55953	L/H TAILPIPE ASSEMBLY
5	4	90116	S/S ACCUSEAL CLAMP: Ø2.75

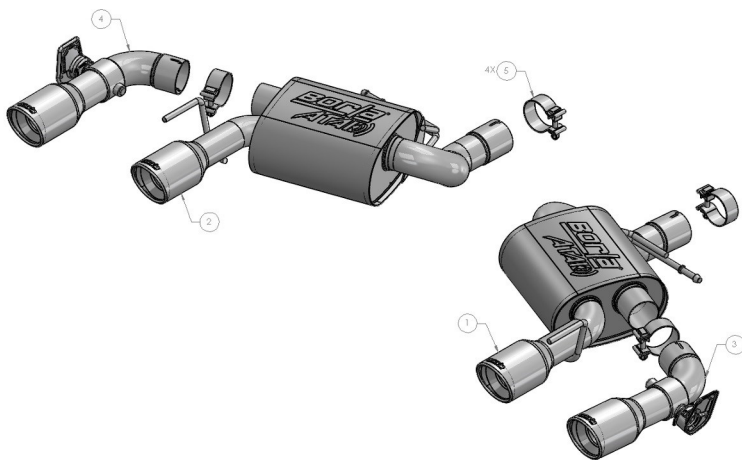

11925

ITEM NO.	QTY.	PART NUMBER	DESCRIPTION
1	1	55981	R/H MUFFLER ASSEMBLY
2	1	55982	L/H MUFFLER ASSEMBLY
3	1	55952	R/H TAILPIPE ASSEMBLY
4	1	55953	L/H TAILPIPE ASSEMBLY
5	4	90116	S/S ACCUSEAL CLAMP: Ø2.75

Minimum Required Tool List:

TOOLS:

1. 3/8” Drive Ratchet
2. 3/8” Drive Extension 9”
3. 15mm Socket
4. 15mm Wrench
5. 14mm Socket
6. 14mm Wrench
7. Pry Bar

SHOP SUPPLIES:

- 1 Spray Lubricant

Borla Performance - Bill of Materials

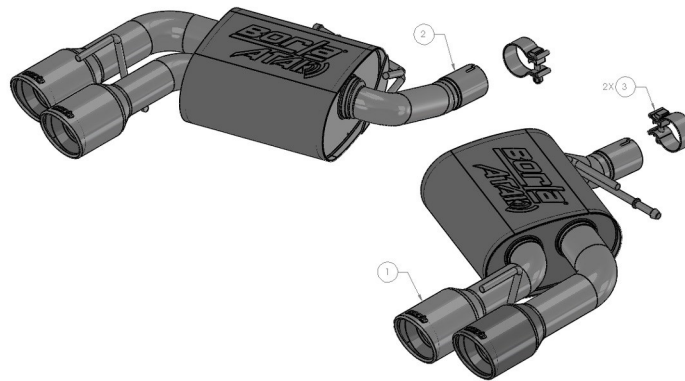

11927

ITEM NO.	QTY.	PART NUMBER	DESCRIPTION
1	1	56016	R/H MUFFLER ASSEMBLY
2	1	56017	L/H MUFFLER ASSEMBLY
3	2	90112	2.25 ACCUSEAL CLAMP

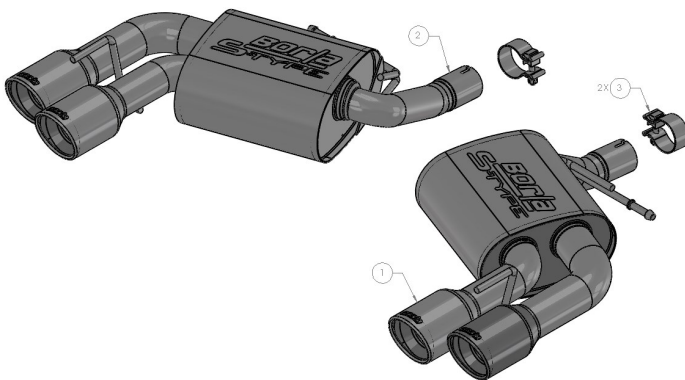

11926

ITEM NO.	QTY.	PART NUMBER	DESCRIPTION
1	1	56014	R/H MUFFLER ASSEMBLY
2	1	56015	L/H MUFFLER ASSEMBLY
3	2	90112	2.25 ACCUSEAL CLAMP

Minimum Required Tool List:

TOOLS:

1. 3/8" Drive Ratchet
2. 3/8" Drive Extension 9"
3. 15mm Socket
4. 15mm Wrench
5. 14mm Socket
6. 14mm Wrench
7. Pry Bar

SHOP SUPPLIES:

- 1 Spray Lubricant

Borla Performance - Bill of Materials

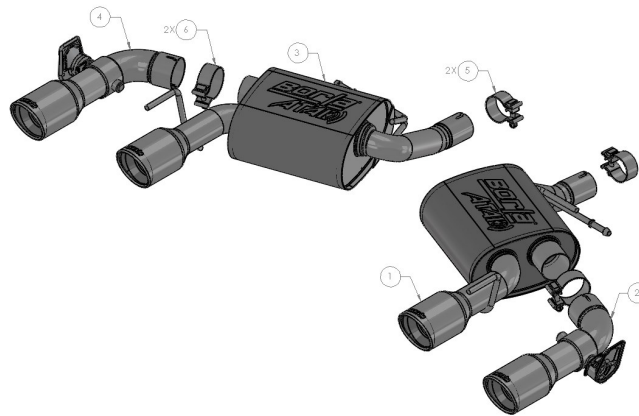

11931

ITEM NO.	QTY.	PART NUMBER	DESCRIPTION
1	1	56020	R/H MUFFLER ASSEMBLY
2	1	55982	R/H TAILPIPE ASSEMBLY
3	1	56021	L/H MUFFLER ASSEMBLY
4	1	55983	L/H TAILPIPE ASSEMBLY
5	2	90112	2.25 ACCUSEAL CLAMP
6	2	90116	3/8 ACCUSEAL CLAMP: Ø2.75

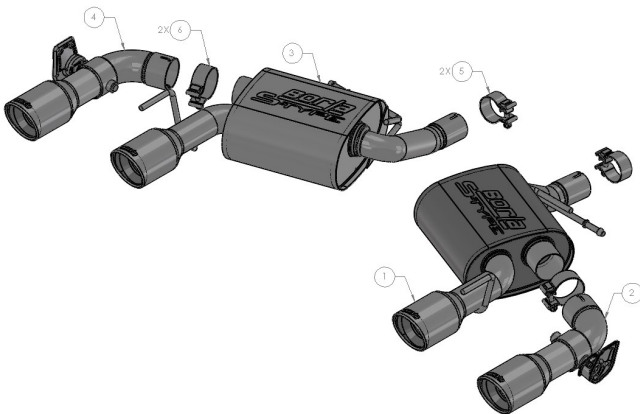

11930

ITEM NO.	QTY.	PART NUMBER	DESCRIPTION
1	1	56018	R/H MUFFLER ASSEMBLY
2	1	55952	R/H TAILPIPE ASSEMBLY
3	1	56019	L/H MUFFLER ASSEMBLY
4	1	55953	L/H TAILPIPE ASSEMBLY
5	2	90112	2.25 ACCUSEAL CLAMP
6	2	90116	3/8 ACCUSEAL CLAMP: Ø2.75

Caution!!! *Never work on a hot exhaust system. Serious injury in the form of burns can result if the vehicle has been in use and the exhaust system is hot, allow vehicle to cool for at least 1 hour. Always wear eye protection when working under any vehicle.*

Note: It is our recommendation that you use a hoist or hydraulic lift to facilitate the installation of your new Borla Performance Exhaust System.

Taking all under car safety precautions, lift the vehicle using a hoist or hydraulic lift. Once this has been done, you may begin the removal of your old exhaust system from your vehicle.

Note: Before removing the original exhaust system from your vehicle, please compare the parts you have received with the bill of materials provided on the previous page to assure that you have all the parts necessary for the installation of your new Borla Performance Exhaust System.

Note: With a used vehicle, we suggest a penetrating spray lubricant to be applied liberally to all exhaust fasteners and allowing a significant period of time for the chemical to lubricate the threads before attempting to disassemble.

Original Exhaust System Removal

1. Left Side and Right Side factory muffler tubing must be cut prior to installation. (See Fig. 1)
2. Sections of factory tubing is flattened for exhaust clearance below rear sub-frame. Begin with Left Side tube and locate intersection of round section and flattened area. Measure and mark cutting line 4-3/8" as shown. Cut tubing with metal-cutting bladed saw. (See Fig. 2A)
3. Repeat Step 2 for Right Side tube and locate intersection of round section and flattened area. Measure and mark cutting line 4-3/8" as shown. (See Fig. 2B)
4. On Left Side locate and remove (2) nuts on Hanger Bracket and remove hanger from bracket. Keep Hanger Bracket and hardware for reinstallation. (See Fig 3)
5. Repeat STEP 4 for Right Side Hanger.
6. Support muffler assembly with stand. Carefully remove hangers from rubber isolators and remove factory rear muffler assembly from vehicle.
7. Deburr sharp edges of cut tubing on vehicle. (See Fig. 4)

WARNING: Use extreme caution during installation. Torque all fasteners according to manufacturer's torque values and tightening sequence. **DO NOT** use air impact tools to tighten fasteners on Borla Performance Exhaust Systems. Use of such tools may result in bent flanges or gasket contact areas leading to exhaust leaks.

NOTE: When you first start your vehicle after the installation of your new Borla Performance Exhaust System, there may be some smoke and fumes coming from the system. This is a protective oil based coating used in the manufacturing of mandrel bent performance exhaust tubing. This is not a problem and will disappear within a very short period of time after the exhaust has reached normal operating temperatures.

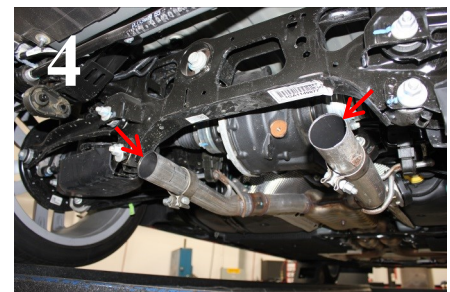
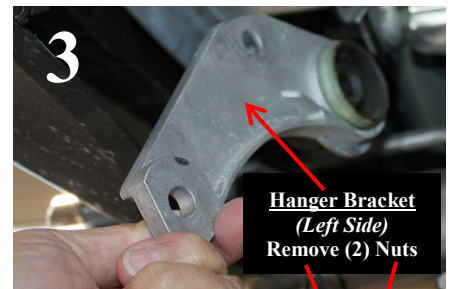
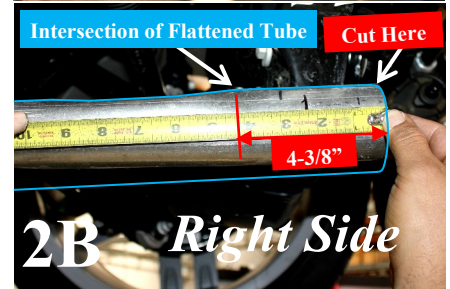
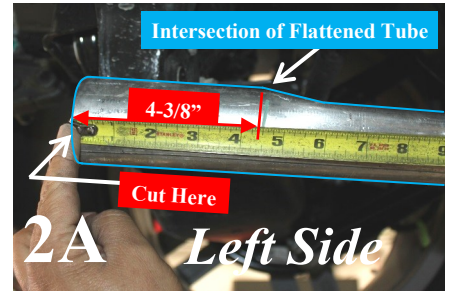
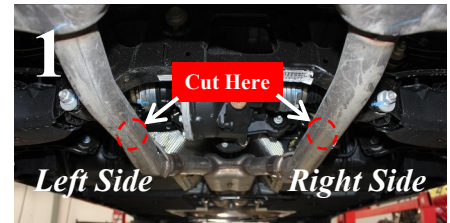

**PRE-ASSEMBLY FOR 11924, 11925,
11930, & 11931 ONLY**
L/S Tail Pipe Assembly
R/S Tail Pipe Assembly

1. Begin with **R/S Muffler Assembly**. Place a clamp on the expanded edge of the **R/S Tip Assembly** and place over the muffler tube. (See Figs. A & B) DO NOT TIGHTEN THE CLAMP BOLT.
2. Repeat STEP 1 for the **L/S Tip Assembly** to **R/S Muffler Assembly**.
3. Transfer both factory electronic actuators from factory exhaust to **L/S Tip Assembly** and **R/S Tip Assembly** using factory hardware. Verify alignment of components and tighten bolts 8 ft. lbs. (See Fig. C)

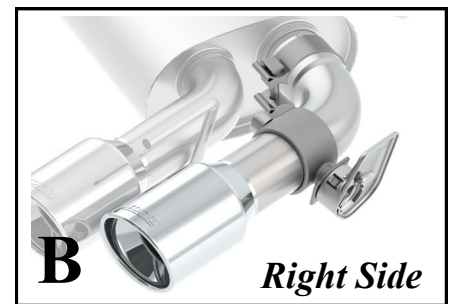
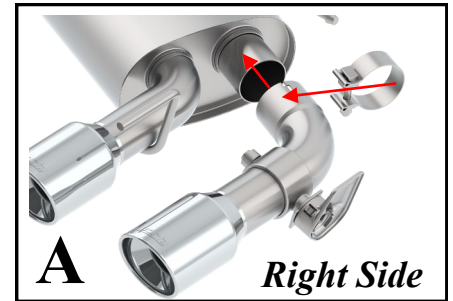

WARNING: Use extreme caution during installation. Torque all fasteners according to manufacturer's torque values and tightening sequence. **DO NOT** use air impact tools to tighten fasteners on Borla Performance Exhaust Systems. Use of such tools may result in bent flanges or gasket contact areas leading to exhaust leaks.

NOTE: When you first start your vehicle after the installation of your new Borla Performance Exhaust System, there may be some smoke and fumes coming from the system. This is a protective oil based coating used in the manufacturing of mandrel bent performance exhaust tubing. This is not a problem and will disappear within a very short period of time after the exhaust has reached normal operating temperatures.

Borla Performance Exhaust Installation

1. Starting on Left Side, place a clamp on expanded end of **L/H Muffler Assembly**. Carefully insert (2) hangers into rubber isolators. **DO NOT TIGHTEN CLAMP BOLTS** (See Figs. 5A & 5B)
2. Repeat Step 1 to install **R/S Muffler Assembly** to vehicle.
3. Reinstall **L/S Muffler Assembly** to vehicle using factory **Left Side Hanger Bracket** using factory hardware. Tighten nuts to 12 ft. lbs. (See Figs. 6A & 6B)
4. Repeat Step 3 to reinstall factory **R/S Muffler Assembly** to vehicle.
5. **11924, 11925, 11930, & 11931 ONLY: Reconnect left-side and right-side wire harness to factory electronic actuators.**
6. Check your exhaust system for proper clearance under the vehicle and also for tip centering to valence. (See Fig. 7)
7. Once position has been determined to be correct, tighten the Muffler Assembly inlet clamp bolts; then the Tailpipe Assembly Tip clamp bolts, 32-35 ft. lbs. (See Fig. 8)
8. Before starting your vehicle, make sure to check all wires, hoses, brake lines, body parts and tires for safe clearance from the exhaust system.
9. Start vehicle and check for any leaks. If any leaks are found, determine cause (such as loose or incorrectly positioned clamp) and repair as necessary.

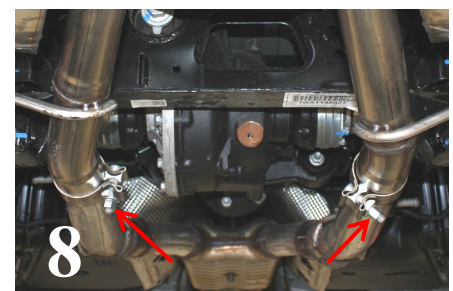
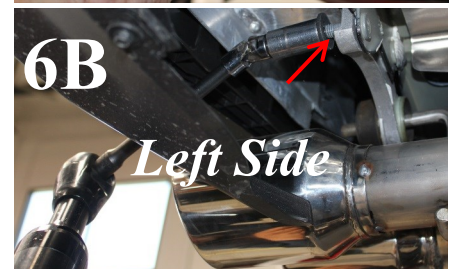
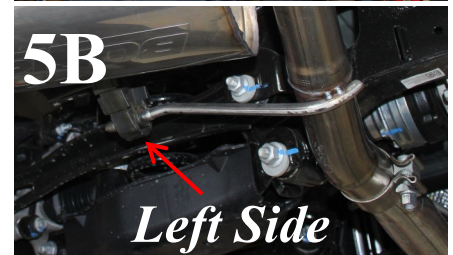

WARNING: Use extreme caution during installation. Torque all fasteners according to manufacturer's torque values and tightening sequence. **DO NOT** use air impact tools to tighten fasteners on Borla Performance Exhaust Systems. Use of such tools may result in bent flanges or gasket contact areas leading to exhaust leaks.

NOTE: When you first start your vehicle after the installation of your new Borla Performance Exhaust System, there may be some smoke and fumes coming from the system. This is a protective oil based coating used in the manufacturing of mandrel bent performance exhaust tubing. This is not a problem and will disappear within a very short period of time after the exhaust has reached normal operating temperatures.