

Chevrolet Camaro PN - 60622 Mid Pipe PN - 60623 Down Pipe* PN- 60624 Touring Resonator



******* Please compare the parts in the box with the bill of materials provided *****
(view the following pages) to assure that you have all the parts necessary for this installation.**

These instructions have been written to help you with the installation of your Borla Performance System. Please read this document completely before beginning the installation of your system.

Thank you for purchasing an Borla Performance Exhaust System.

Borla Performance Components (PNs 60622, 60623, & 60624) are designed for the Chevrolet Camaro equipped with a 2.0T 4-Cylinder Turbo engine, automatic or manual transmission.

PN-60623 IS NOT EMISSIONS COMPLIANT. ** FOR COMPETITION USE ONLY **

Borla Performance Industries recommends that an exhaust shop or professional after market parts installer, who has all the necessary equipment, tools and experienced personnel needed for proper installation, should perform the installation of this system. However, if you decide to perform the installation, we recommend someone should help you. Ensure the installer uses all under car safety precautions including eye protection.

Please take time to read and understand the following...

By installing your Borla Performance Exhaust System, you indicate that you have read this document and you agree with the terms stated below.

It is the responsibility of the purchaser to follow all installation instruction guidelines and safety procedures supplied with your Borla Performance Exhaust System.

Borla Performance Industries assumes no responsibility for damages occurring from misuse, abuse, improper installation, improper operation, lack of responsible care, or all previously stated reasons resulting from incompatibility with other manufacturer's products and/or systems.

Included with your Borla Performance Exhaust System is a warranty card. Please read it carefully before you begin any work on your vehicle. If you should have any questions regarding our warranty policy, installation, or any other matter pertaining to your new Borla Performance Exhaust System, please give us a call at the number provided on the warranty card.

Minimum Required Tool List:**TOOLS:**

1. 3/8" Drive Ratchet
2. 3/8" Drive Extension 6" & 9"
3. 7/8 Wrench
4. 15mm Socket
5. 15mm Wrench
6. 14mm Socket
7. 13mm Socket
8. 10mm Socket
9. Pry Bar

SHOP SUPPLIES:

- 1 Spray Lubricant

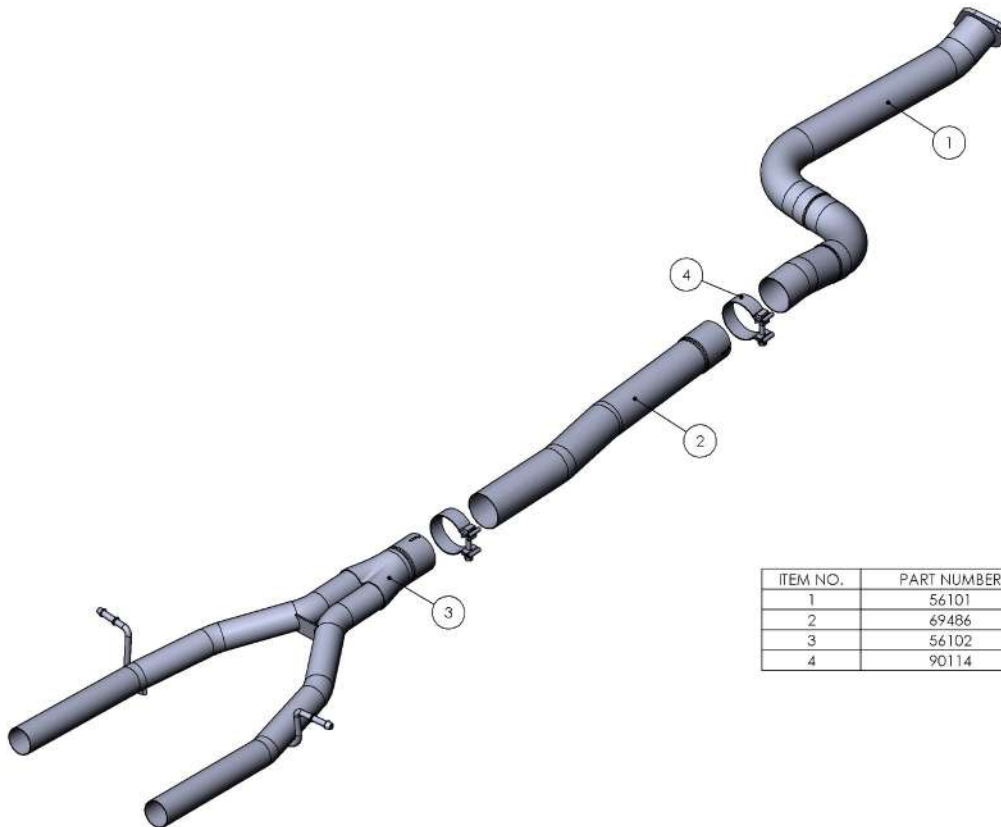
Borla Performance - Bill of Materials**60622**

ITEM NO.	PART NUMBER	DESCRIPTION	QTY.
1	56101	FRONT PIPE ASSEMBLY	1
2	69486	INTERMEDIATE PIPE: Ø3.00 X 26.58	1
3	56102	Y-PIPE ASSEMBLY	1
4	90114	3.00 ACCUSEAL CLAMP	2

Minimum Required Tool List:

TOOLS:

1. 3/8" Drive Ratchet
2. 3/8" Drive Extension 6" & 9"
3. 7/8 Wrench
4. 15mm Socket
5. 15mm Wrench
6. 14mm Socket
7. 13mm Socket
8. 10mm Socket
9. Pry Bar

SHOP SUPPLIES:

- 1 Spray Lubricant

Borla Performance - Bill of Materials

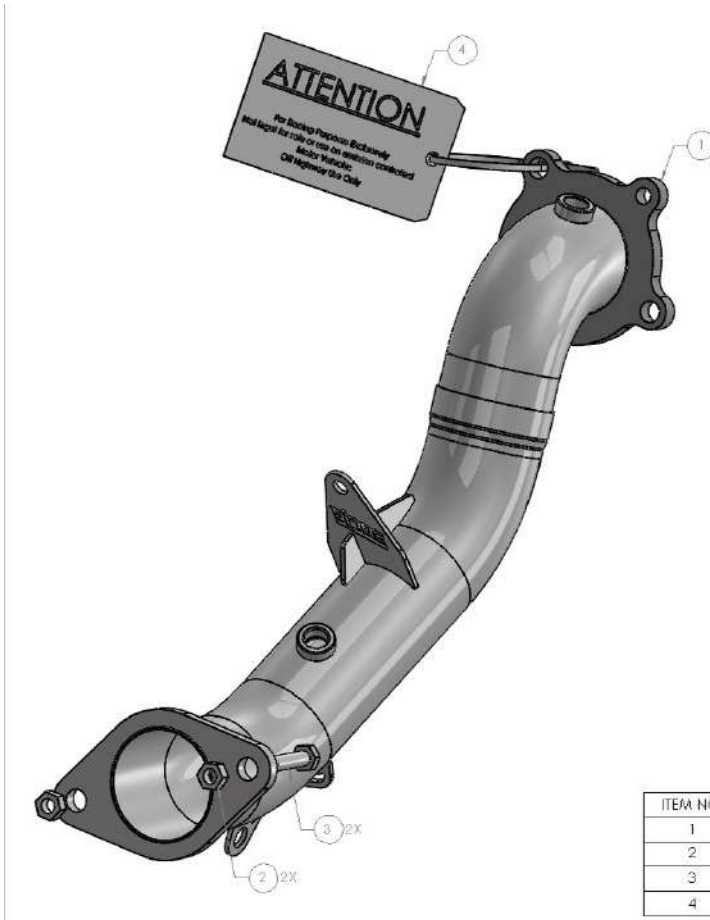

60623

ITEM NO.	QTY.	PART NUMBER	DESCRIPTION
1	1	56100	DOWNPIPE ASSEMBLY
2	2	11514597	NUT: HXHD, M10 X 1.50p
3	2	91030	SCREW: Cap, Hxhd, M10 x 40mm x 1.5p
4	1	96240	OFF HIGHWAY USE ONLY DISCLAIMER

Minimum Required Tool List:**TOOLS:**

1. 3/8" Drive Ratchet
2. 3/8" Drive Extension 6" & 9"
3. 7/8 Wrench
4. 15mm Socket
5. 15mm Wrench
6. 14mm Socket
7. 13mm Socket
8. 10mm Socket
9. Pry Bar

SHOP SUPPLIES:

- 1 Spray Lubricant

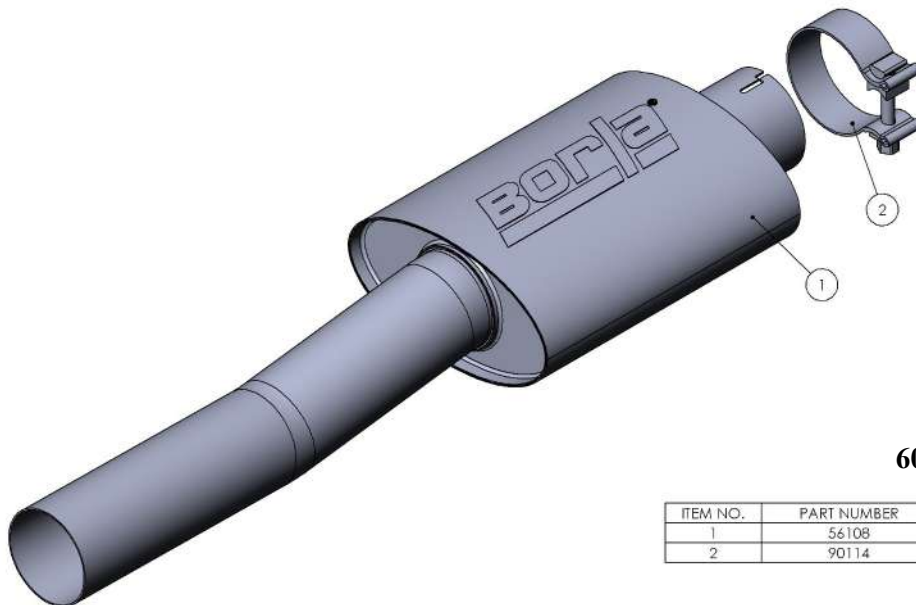
Borla Performance - Bill of Materials**60624**

ITEM NO.	PART NUMBER	DESCRIPTION	QTY.
1	56108	MUFFLER ASSEMBLY	1
2	90114	3.00 ACCUSEAL CLAMP	1

Caution!!! *Never work on a hot exhaust system. Serious injury in the form of burns can result. If the vehicle has been in use and the exhaust system is hot, allow vehicle to cool for at least 1 hour. Always wear eye protection when working under any vehicle.*

Note: *It is our recommendation that you use a hoist or hydraulic lift to facilitate the installation of your new Borla Performance Exhaust System.*

Taking all under car safety precautions, lift the vehicle using a hoist or hydraulic lift. Once this has been done, you may begin the removal of your old exhaust system from your vehicle.

Note: *Before removing the original exhaust system from your vehicle, please compare the parts you have received with the bill of materials provided on the previous page to assure that you have all the parts necessary for the installation of your new Borla Performance Exhaust System.*

Note: *With a used vehicle, we suggest a penetrating spray lubricant to be applied liberally to all exhaust fasteners and allowing a significant period of time for the chemical to lubricate the threads before attempting to disassemble.*

Original Exhaust System Removal

1. Remove Rear Mufflers (REFER TO BORLA REAR SECTION INSTALLATION GUIDE).
2. Remove factory cross brace and keep hardware for installation later. (See Fig. 1)
3. Loosen and remove hardware on factory Mid Pipe flange keeping hardware for installation later. (See Fig. 2)
4. On Left Side locate and remove (2) nuts on Hanger Bracket and remove hanger from bracket. Keep Hanger Bracket and hardware for reinstallation. (See Fig 3)
5. Repeat STEP 3 for Right Side removal.
6. Remove hangers from rubber isolators and carefully remove factory midpipe from vehicle. (See Fig. 4)

WARNING: *Use extreme caution during installation. Torque all fasteners according to manufacturer's torque values and tightening sequence. **DO NOT** use air impact tools to tighten fasteners on Borla Performance Exhaust Systems. Use of such tools may result in bent flanges or gasket contact areas leading to exhaust leaks.*

NOTE: *When you first start your vehicle after the installation of your new Borla Performance Exhaust System, there may be some smoke and fumes coming from the system. This is a protective oil based coating used in the manufacturing of mandrel bent performance exhaust tubing. This is not a problem and will disappear within a very short period of time after the exhaust has reached normal operating temperatures.*

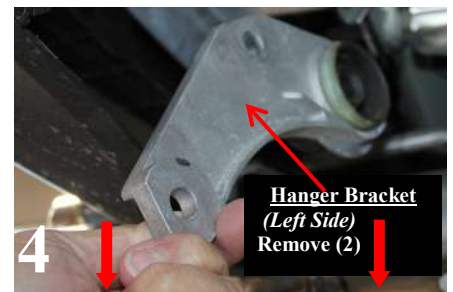

Caution!!! *Never work on a hot exhaust system. Serious injury in the form of burns can result if the vehicle has been in use and the exhaust system is hot, allow vehicle to cool for at least 1 hour. Always wear eye protection when working under any vehicle.*

Note: *It is our recommendation that you use a hoist or hydraulic lift to facilitate the installation of your new Borla Performance Exhaust System.*

Taking all under car safety precautions, lift the vehicle using a hoist or hydraulic lift. Once this has been done, you may begin the removal of your old exhaust system from your vehicle.

Note: *Before removing the original exhaust system from your vehicle, please compare the parts you have received with the bill of materials provided on the previous page to assure that you have all the parts necessary for the installation of your new Borla Performance Exhaust System.*

Note: *With a used vehicle, we suggest a penetrating spray lubricant to be applied liberally to all exhaust fasteners and allowing a significant period of time for the chemical to lubricate the threads before attempting to disassemble.*

Original Down Pipe Removal

1. Lubricate all hangers, robber isolators, bolts and nuts.
2. Loosen and remove hardware connecting OE down pipe to exhaust. Use a muffler stand to support exhaust front pipe. (See Fig. 6)
3. Remove heat shell kipping hardware for re-installation on your new down pipe. (See Fig. 7)
4. Loosen and remove (4) mounting nuts from the flange place hardware to aside, remove O2 sensor. (See Fig. 8)
5. Remove the down pipe assembly, but loosen and remove (1) mounting bolt on the bracket, for more clearance and disconnect O2 Sensor. (See Fig. 9)
6. Support down pipe assembly with stand. Carefully remove factory down pipe assembly from vehicle.
7. Original down pipe removed. (See Fig. 10)

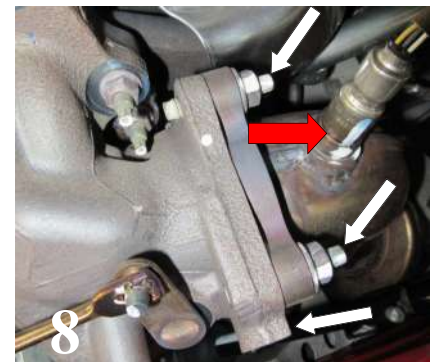
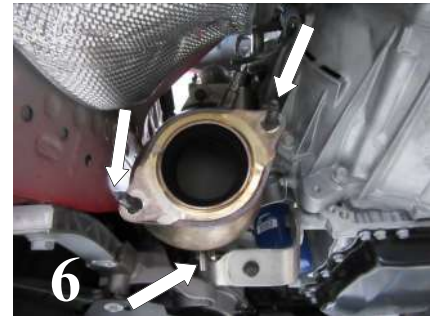

WARNING: *Use extreme caution during installation. Torque all fasteners according to manufacturer's torque values and tightening sequence. **DO NOT** use air impact tools to tighten fasteners on Borla Performance Exhaust Systems. Use of such tools may result in bent flanges or gasket contact areas leading to exhaust leaks.*

NOTE: *When you first start your vehicle after the installation of your new Borla Performance Exhaust System, there may be some smoke and fumes coming from the system. This is a protective oil based coating used in the manufacturing of mandrel bent performance exhaust tubing. This is not a problem and will disappear within a very short period of time after the exhaust has reached normal operating temperatures.*

Borla Performance Down Pipe Installation

1. Place down pipe into position, using the original hardware secure the flange. (See Fig. 11)
2. Secure down pipe using (2) original bolts on the bracket, and making sure to install OE 02 Sensor to 60623 **Down pipe Assembly**. (See Fig.12)
3. Transfer gasket to your new down pipe and use the hardware that is provided. (See Fig. 13)
4. Place front pipe into position using a muffler Stan or an additional person, to hold front pipe into position and place a Accuseal clamp. (See Fig. 14)
5. Install remaining exhaust system per manufacturer recommendations.
6. Check your exhaust system for proper clearance under the vehicle and also for tip centering to valence. Once position has been determined to be correct, tighten the Muffler Assembly inlet clamp bolts; then the Tailpipe Assembly Tip clamp bolts, 32-35 ft. lbs.
7. Before starting your vehicle, make sure to check all wires, hoses, brake lines, body parts and tires for safe clearance from the exhaust system. (See Fig. 15)
8. Start vehicle and check for any leaks. If any leaks are found, determine cause (such as loose or incorrectly positioned clamp) and repair as necessary.

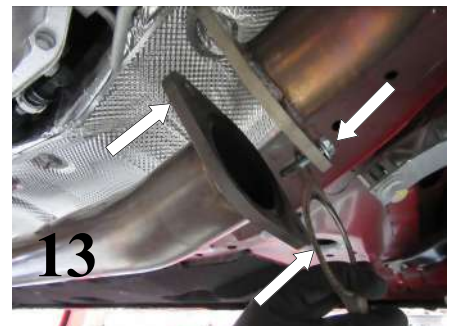
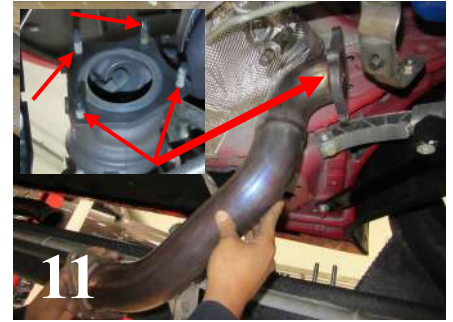

WARNING: Use extreme caution during installation. Torque all fasteners according to manufacturer's torque values and tightening sequence. **DO NOT** use air impact tools to tighten fasteners on Borla Performance Exhaust Systems. Use of such tools may result in bent flanges or gasket contact areas leading to exhaust leaks.

NOTE: When you first start your vehicle after the installation of your new Borla Performance Exhaust System, there may be some smoke and fumes coming from the system. This is a protective oil based coating used in the manufacturing of mandrel bent performance exhaust tubing. This is not a problem and will disappear within a very short period of time after the exhaust has reached normal operating temperatures.

Borla Performance Mid Pipe Installation

1. Place a clamp on each expanded end of the **Front Pipe Assembly** and insert to the cut outlet pipes.
2. Place one clamp on each expanded end of two **Mid Pipes** (or **Touring Resonator Option PN-60624**) and insert the ends into each outlet of installed **Front Pipe** outlet. (See Figs. 17 or 18)
3. Place a clamp on each expanded end of the **X-Pipe** and insert ends to the installed **Mid Pipe** (or **Touring Resonator Option PN-60608**) outlet. Place a clamp over each outlet of the **Mid Pipe**. (See Fig. 19)
4. *Refer to installation instructions for your Borla Rear Section Mufflers.*
5. *Its best to start tightening hardware from the front of the vehicle then moving to the rear.* Once position has been determined to be correct, tighten the clamp bolts, 32-35 ft. lbs. and flange hardware 15-17 ft. lbs. (See Fig. 20)
6. Before starting your vehicle, make sure to check all wires, hoses, brake lines, body parts and tires for safe clearance from the exhaust system.
7. Start vehicle and check for any leaks. If any leaks are found, determine cause (such as loose or incorrectly positioned clamp) and repair as necessary.



WARNING: Use extreme caution during installation. Torque all fasteners according to manufacturer's torque values and tightening sequence. **DO NOT** use air impact tools to tighten fasteners on Borla Performance Exhaust Systems. Use of such tools may result in bent flanges or gasket contact areas leading to exhaust leaks.

NOTE: When you first start your vehicle after the installation of your new Borla Performance Exhaust System, there may be some smoke and fumes coming from the system. This is a protective oil based coating used in the manufacturing of mandrel bent performance exhaust tubing. This is not a problem and will disappear within a very short period of time after the exhaust has reached normal operating temperatures.

Borla Performance Exhaust Installation

1. Starting on Left Side, place a clamp on expanded end of **L/H Muffler Assembly**. Carefully insert (2) hangers into rubber isolators. DO NOT TIGHTEN CLAMP BOLTS (See Figs. 21 & 22)
2. Repeat STEP 1 to install **R/S Muffler Assembly** to vehicle.
3. Reinstall **L/S Muffler Assembly** to vehicle using factory Left Side Hanger Bracket using factory hardware. Tighten nuts to 12 ft. lbs. (See Figs. 23 & 24)
4. Repeat STEP 3 to reinstall factory **R/S Muffler Assembly** to vehicle.
5. Check your exhaust system for proper clearance under the vehicle and also for tip centering to valence. (See Fig. 25)
6. Once position has been determined to be correct, tighten the Muffler Assembly inlet clamp bolts 32-35 ft. lbs. (See Fig. 26)
7. Before starting your vehicle, make sure to check all wires, hoses, brake lines, body parts and tires for safe clearance from the exhaust system.
8. Start vehicle and check for any leaks. If any leaks are found, determine cause (such as loose or incorrectly positioned clamp) and repair as necessary.

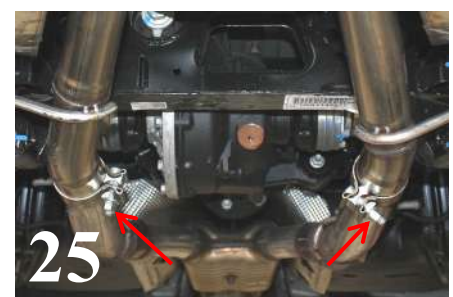

WARNING: Use extreme caution during installation. Torque all fasteners according to manufacturer's torque values and tightening sequence. **DO NOT** use air impact tools to tighten fasteners on Borla Performance Exhaust Systems. Use of such tools may result in bent flanges or gasket contact areas leading to exhaust leaks.

NOTE: When you first start your vehicle after the installation of your new Borla Performance Exhaust System, there may be some smoke and fumes coming from the system. This is a protective oil based coating used in the manufacturing of mandrel bent performance exhaust tubing. This is not a problem and will disappear within a very short period of time after the exhaust has reached normal operating temperatures.