

Chevrolet Camaro (Gen6) Installation Guide PN- 60605



******* Please compare the parts in the box with the bill of materials provided *****
(view the following pages) to assure that you have all the parts necessary for this installation.**

These instructions have been written to help you with the installation of your Borla Performance System. Please read this document completely before beginning the installation of your system.

Thank you for purchasing a Borla Performance Exhaust System.

The Borla Performance Exhaust Tail Pipe Assembly (PN 60605) is designed for Borla Mufflers for the Chevrolet Camaro with a 6.2L-V8 or 3.6L-V6 engines, manual or automatic transmissions.

Borla Performance Industries recommends that an exhaust shop or professional after market parts installer, who has all the necessary equipment, tools and experienced personnel needed for proper installation, should perform the installation of this system. However, if you decide to perform the installation, we recommend someone should help you. Ensure the installer uses all under car safety precautions including eye protection.

Please take time to read and understand the following...

By installing your Borla Performance Exhaust System, you indicate that you have read this document and you agree with the terms stated below.

It is the responsibility of the purchaser to follow all installation instruction guidelines and safety procedures supplied with your Borla Performance Exhaust System.

Borla Performance Industries assumes no responsibility for damages occurring from misuse, abuse, improper installation, improper operation, lack of responsible care, or all previously stated reasons resulting from incompatibility with other manufacturer's products and/or systems.

Included with your Borla Performance Exhaust System is a warranty card. Please read it carefully before you begin any work on your vehicle. If you should have any questions regarding our warranty policy, installation, or any other matter pertaining to your new Borla Performance Exhaust System, please give us a call at the number provided on the warranty card.

Minimum Required Tool List:

TOOLS:

1. 3/8" Drive Ratchet
2. 3/8" Drive Extension 9"
3. 15mm Socket
4. 15mm Wrench
5. 14mm Socket
6. 14mm Wrench
7. Pry Bar

SHOP SUPPLIES:

- 1 Spray Lubricant

Borla Performance - Bill of Materials

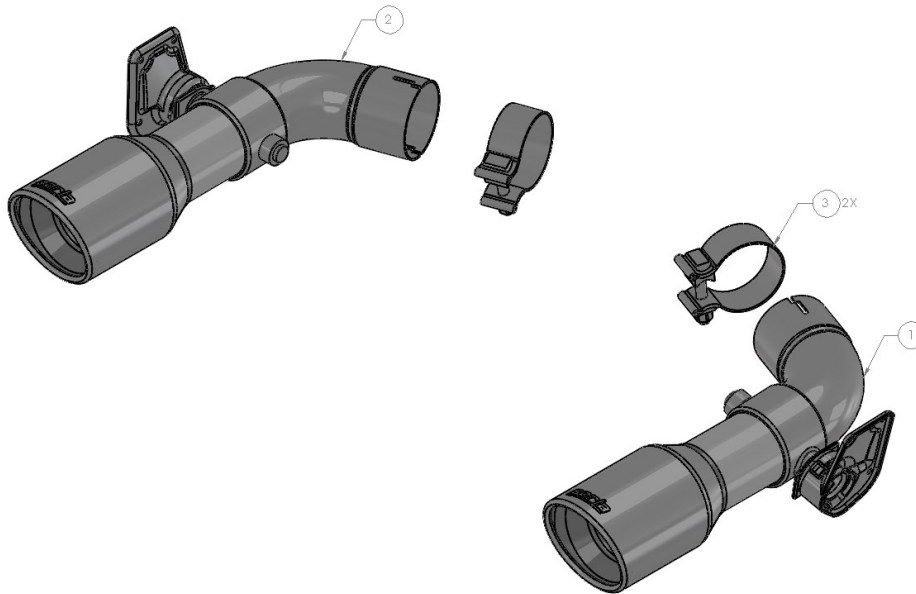

6065

ITEM NO.	QTY.	PART NUMBER	DESCRIPTION
1	1	55952	R/H TAILPIPE ASSEMBLY
2	1	55953	L/H TAILPIPE ASSEMBLY
3	2	90116	S/S ACCUSEAL CLAMP: Ø2.75

Caution!!! *Never work on a hot exhaust system. Serious injury in the form of burns can result. If the vehicle has been in use and the exhaust system is hot, allow vehicle to cool for at least 1 hour. Always wear eye protection when working under any vehicle.*

Note: *It is our recommendation that you use a hoist or hydraulic lift to facilitate the installation of your new Borla Performance Exhaust System.*

Taking all under car safety precautions, lift the vehicle using a hoist or hydraulic lift. Once this has been done, you may begin the removal of your old exhaust system from your vehicle.

Note: *Before removing the original exhaust system from your vehicle, please compare the parts you have received with the bill of materials provided on the previous page to assure that you have all the parts necessary for the installation of your new Borla Performance Exhaust System.*

Note: *With a used vehicle, we suggest a penetrating spray lubricant to be applied liberally to all exhaust fasteners and allowing a significant period of time for the chemical to lubricate the threads before attempting to disassemble.*

Original Exhaust System Removal

- 1. Disconnect left-side and right-side wire harness to factory electronic actuators.**
- Loosen (2) clamps on securing rear muffler assemblies. (See Figs. 1 & 2)
- Starting on the left-side, locate and remove (2) nuts on Hanger Bracket and remove hanger from bracket. Keep Hanger Bracket and hardware for reinstallation. (See Figs. 3A & 3B)
- Repeat STEP 2 for right-side Hanger.
- Support muffler assembly with stand. Carefully remove hangers from rubber isolators and remove both rear muffler assemblies from vehicle. (See Figs. 4A & 4B)

WARNING: *Use extreme caution during installation. Torque all fasteners according to manufacturer's torque values and tightening sequence. **DO NOT** use air impact tools to tighten fasteners on Borla Performance Exhaust Systems. Use of such tools may result in bent flanges or gasket contact areas leading to exhaust leaks.*

NOTE: *When you first start your vehicle after the installation of your new Borla Performance Exhaust System, there may be some smoke and fumes coming from the system. This is a protective oil based coating used in the manufacturing of mandrel bent performance exhaust tubing. This is not a problem and will disappear within a very short period of time after the exhaust has reached normal operating temperatures.*

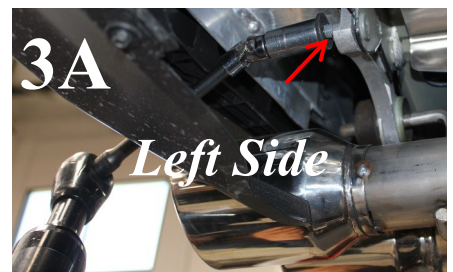
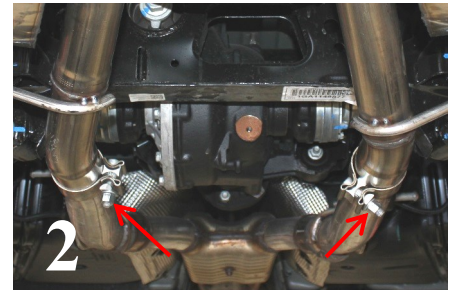

Replace Tail Pipe Assembly (60605)

1. Begin with **R/S Muffler Assembly**. Loosen clamp on right-side clamp and remove old R/S Tail Pipe Assembly from muffler assembly.
2. Remove the electronic actuator on vehicle right-side rear muffler assembly. (See Fig. A)
3. Transfer (removed) factory electronic actuator to new **R/S Tailpipe Assembly** using factory hardware. Verify alignment of components and tighten bolts 8 ft. lbs.
4. Place a clamp on the expanded edge of the **R/S Tailpipe Assembly** and place over the exposed muffler tube. (See Figs. B & C) DO NOT TIGHTEN THE CLAMP BOLT.
5. Repeat STEPS 1-4 to replace the **L/S Tailpipe Assembly** to **L/S Muffler**.

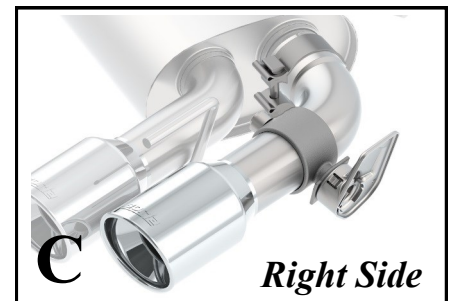
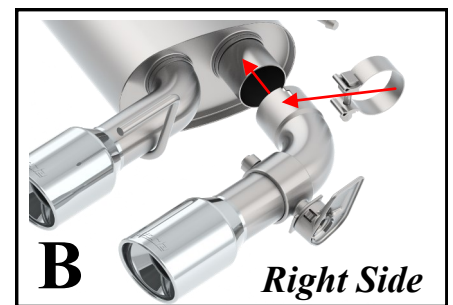

WARNING: Use extreme caution during installation. Torque all fasteners according to manufacturer's torque values and tightening sequence. **DO NOT** use air impact tools to tighten fasteners on Borla Performance Exhaust Systems. Use of such tools may result in bent flanges or gasket contact areas leading to exhaust leaks.

NOTE: When you first start your vehicle after the installation of your new Borla Performance Exhaust System, there may be some smoke and fumes coming from the system. This is a protective oil based coating used in the manufacturing of mandrel bent performance exhaust tubing. This is not a problem and will disappear within a very short period of time after the exhaust has reached normal operating temperatures.

Borla Performance Exhaust Installation

1. Starting on Left Side, place a clamp on expanded end of **L/H Muffler Assembly**. Carefully insert (2) hangers into rubber isolators. DO NOT TIGHTEN CLAMP BOLTS (See Figs. 5A & 5B)
2. Repeat Step 1 to install **R/S Muffler Assembly** to vehicle.
3. Reinstall **L/S Muffler Assembly** to vehicle using factory Left Side Hanger Bracket using factory hardware. Tighten nuts to 12 ft. lbs. (See Figs. 6A & 6B)
4. Repeat Step 3 to reinstall factory **R/S Muffler Assembly** to vehicle.
5. **Reconnect left-side and right-side wire harness to factory electronic actuators.**
6. Check your exhaust system for proper clearance under the vehicle and also for tip centering to valence. (See Fig. 7)
7. Once position has been determined to be correct, tighten the Muffler Assembly inlet clamp bolts; then the Tailpipe Assembly Tip clamp bolts, 32-35 ft. lbs. (See Fig. 8)
8. Before starting your vehicle, make sure to check all wires, hoses, brake lines, body parts and tires for safe clearance from the exhaust system.
9. Start vehicle and check for any leaks. If any leaks are found, determine cause (such as loose or incorrectly positioned clamp) and repair as necessary.

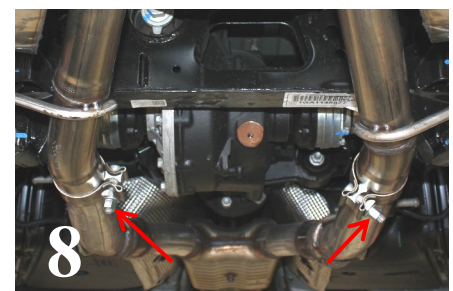
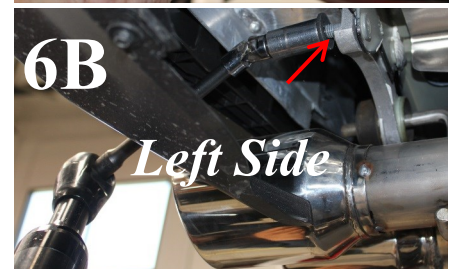
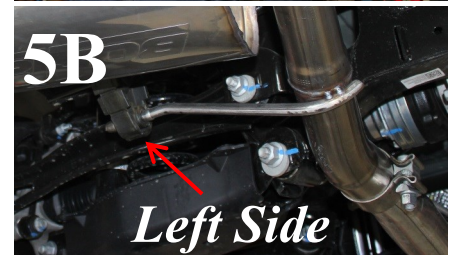

WARNING: Use extreme caution during installation. Torque all fasteners according to manufacturer's torque values and tightening sequence. **DO NOT** use air impact tools to tighten fasteners on Borla Performance Exhaust Systems. Use of such tools may result in bent flanges or gasket contact areas leading to exhaust leaks.

NOTE: When you first start your vehicle after the installation of your new Borla Performance Exhaust System, there may be some smoke and fumes coming from the system. This is a protective oil based coating used in the manufacturing of mandrel bent performance exhaust tubing. This is not a problem and will disappear within a very short period of time after the exhaust has reached normal operating temperatures.