

CrateMuffler™ Installation Guide

*** Required Inlet/Outlet Muffler Orientation ***

Borla Performance Industries, Inc. created the CrateMuffler™ specifically for the high-end hot rod builder market. The Borla CrateMuffler™ is an industry-first product tailored to specific engine displacement/power ratings. The Borla CrateMuffler™ is as unique as the engines they're matched to focusing on terrific sound, optimal performance, improved aesthetics, and minimal highway cruising cabin resonance. The materials and construction are Borla-proven T304 stainless steel with an upscale brush-finish and the Borla Million-Mile Warranty.

Borla Performance engineers spent hundreds of hours fabricating, installing, and sound-testing many prototypes on various popular vehicle/engine configurations. This process included the available muffler space, typical hanger placement, and overall muffler aesthetics. During the research and development we tested and evaluated each CrateMuffler™ on engines installed in numerous vehicle platforms. In summary we optimized each CrateMuffler™ to function in a specific directional-flow of vehicle exhaust.

While your CrateMuffler™ will work if installed in a reverse direction, sound attenuation will be compromised if the exhaust flow is reversed. Please verify the exhaust flow is exiting the ENDPLATE side for the best sound and overall performance.

We incorporated visual design elements to help ensure your CrateMuffler™ is properly installed. Please refer to this installation guide for planning and during the installation process.

Here is a quick overview of the features and *advantages* of the ENDPLATE on your CrateMuffler™:

The OUTLET TUBE is located on the same side of the ENDPLATE. The ENDPLATE is welded-in with a Borla logo displayed when viewed from the rear of the vehicle. *Whether you have Offset-Center or Offset-Offset CrateMuffler™, you'll get the best sound and aesthetic advantages using this orientation.*

The ENDPLATE can be used as a direct-weld mount for hangers or a removable hanger mount using Borla ENDPLATE BRACKETS (available separately*). *Either method ensures a terrific look and secure mount. *Please see pages 2-6 of this installation guide for further information.*

The ENDPLATE can be customized (by the customer) to match the vehicle in paint or polishing. *This option allows flexibility to the fabricator for a unique finish to compliment the vehicle.*

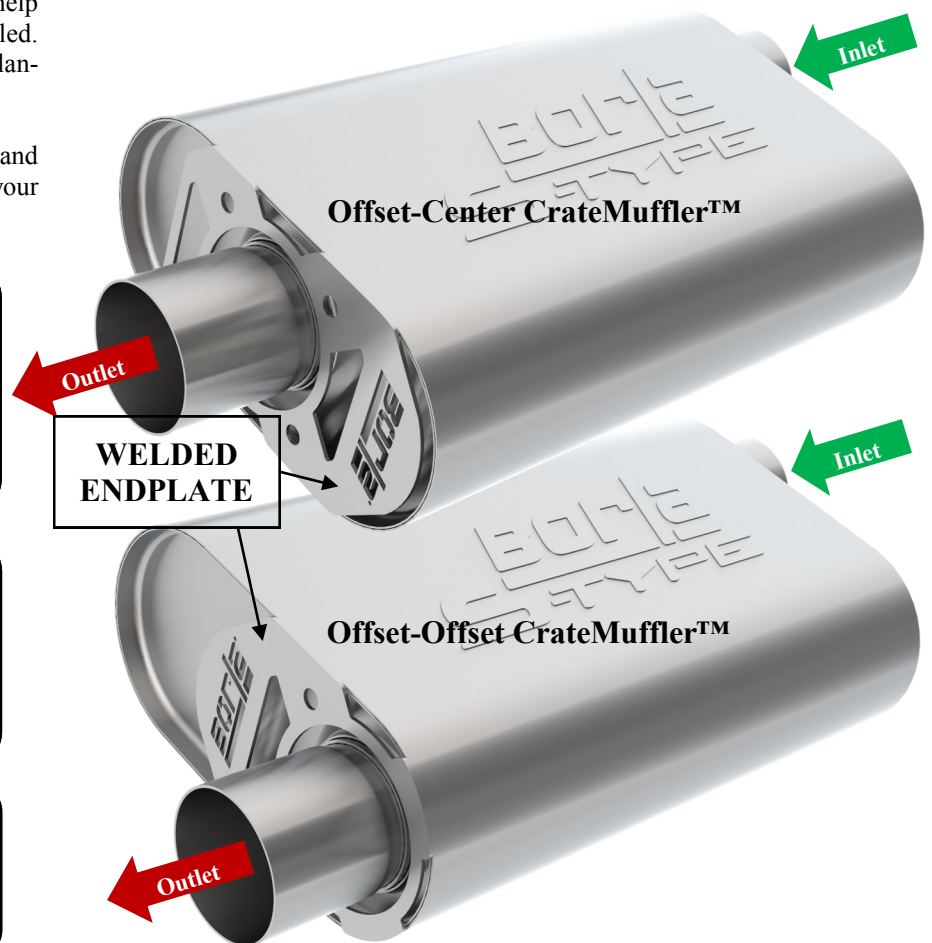

CrateMuffler™ Installation Guide

*** TOURING RESONATOR OPTION ***

At Borla Performance Industries, Inc. we understand what you hear in the exhaust note (engine sound and sound pressure levels) is a subjective topic. While we can identify and minimize unwanted cabin resonances, the loudness or Sound Pressure Level (SPL) is always a topic of discussion with a final decision determined by the vehicle owner.

Vehicle exterior SPL is measured in decibels (dB) using a calibrated instrument at a set distance, angle, and height from the exhaust system outlet. An interior SPL reading is a more complex measurement typically from the drivers seat using head-mounted microphones. Frequencies vary throughout the rpm band and these variations at higher SPL may cause uncomfortable resonances in the cabin. A solution to remedy this resonances is often fixed adding more muffler to attenuate the sound.

If you want to lower the SPL of your new CrateMuffler™, you can install the Borla Touring Resonator Option. The Touring Resonator Option is designed to attenuate overall sound. This is perfect for customers looking to reducing the sound level 2-3 dB(A). This straight-through design will not degrade the performance of your vehicle.

The Borla Touring Resonator Option is available in the same tubing diameters of your CrateMuffler™ and constructed in T304 stainless steel, and backed by the Borla Million-Mile Warranty. Borla recommends welding (not clamping) the Borla Touring Resonator Option for final installation.



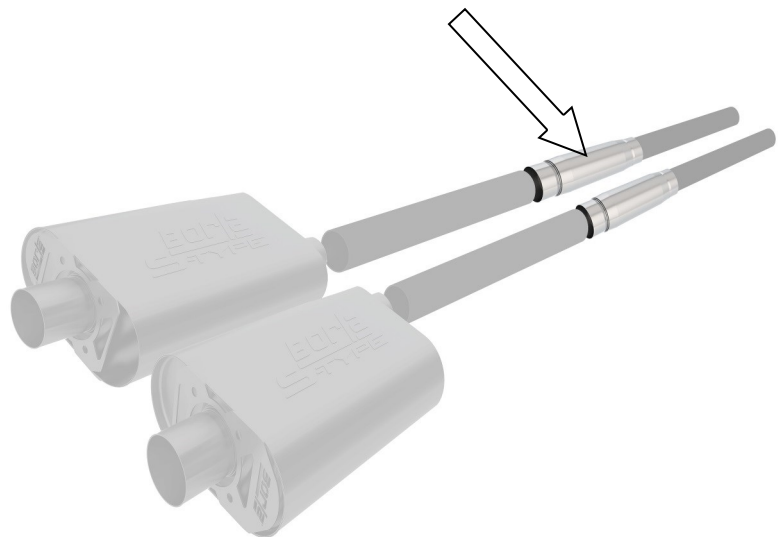

CrateMuffler™ Touring Resonator Option

The **BORLA TOURING RESONATOR OPTION** is available in 2.25", 2.50", and 3.00" tubing diameters. The outside diameter is 4.00" as it is designed to fit in the tight spaces of the current exhaust path. These are designed to be welded (not clamped) for installation and positioned in front of the CrateMuffler™ as shown.

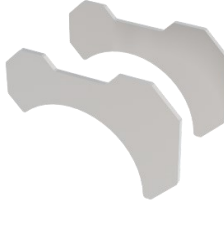
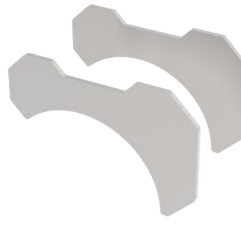
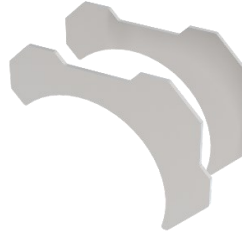

CrateMuffler™ Installation Guide

*** OPTIONAL ACCESSORIES (Available Separately)***

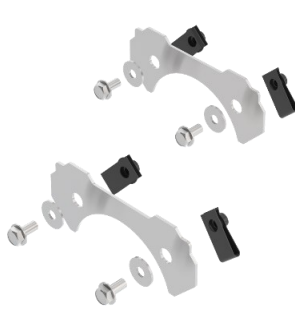
60578 (2.25" Dia. Tubing)	60579 (2.50" Dia. Tubing)	60580 (3.00" Dia. Tubing)
		
60582		60581
		

******* Please compare the parts in the box with the bill of materials provided *****
(view the following pages) to assure that you have all the parts necessary for this installation.**

These instructions have been written to help you with the installation of your Borla Performance System. Please read this document completely before beginning the installation of your system.

Borla Performance Industries recommends that an exhaust shop or professional after market parts installer perform the installation of this system. However, if you decide to perform the installation on your own it is recommended that two people work together. This installation should not be performed by one person due to the risk of injury. Ensure the installers use all under car safety precautions including eye protection.

Please take time to read and understand the following...

By installing your Borla Performance Exhaust Accessory, you indicate that you have read this document and you agree with the terms stated below.

It is the responsibility of the purchaser to follow all installation instruction guidelines and safety procedures supplied with your Borla Performance Accessory.

Borla Performance Industries assumes no responsibility for damages occurring from misuse, abuse, improper installation, improper operation, lack of responsible care, or all previously stated reasons resulting from incompatibility with other manufacturer's products and/or systems.

Included with your Borla Performance Accessory is a warranty card. Please read it carefully before you begin any work on your vehicle. If you should have any questions regarding our warranty policy, installation, or any other matter pertaining to your new Borla Performance Accessory, please give us a call at the number provided on the warranty card.

Borla Performance - Bill of Materials PN-60581

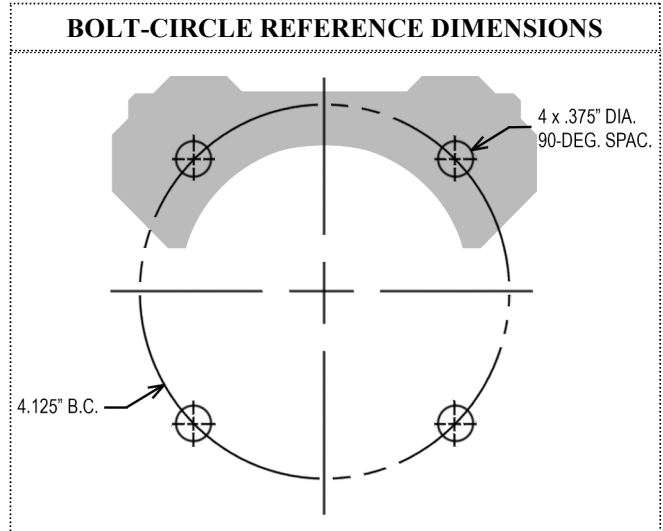
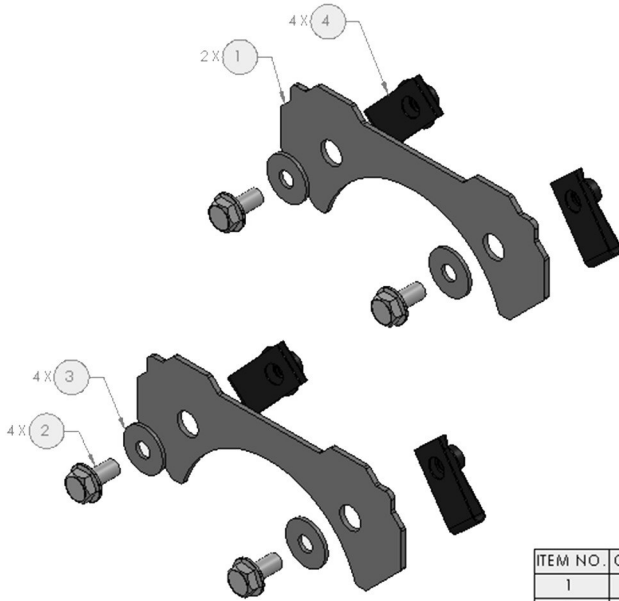

60581 Endplate Bracket Kit

ITEM NO.	QTY.	PART NUMBER	DESCRIPTION
1	2	22461	ENDPLATE BRACKET
2	4	92244444	BOLT/SCREW-EXH MANIF H/SHLD
3	4	92039	Flat Washer: M6 Screw Size, 1.8mm OD
4	4	93077	Clip-on Nut: M6 Size, 1mm Pitch

Borla Performance - Bill of Materials PN-60582

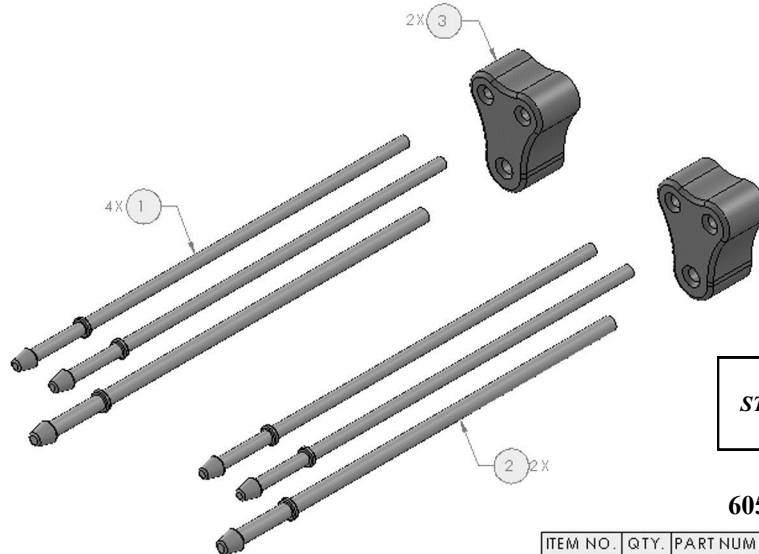

NOTE: HANGERS IN THIS KIT ARE IN STRAIGHT SECTIONS. BEND HANGERS AS REQUIRED FOR INSTALLATION.

60582 8-PC Hanger Kit

ITEM NO.	QTY.	PART NUMBER	DESCRIPTION
1	4	73227	HANGER: DIA.(8mm).31 X 12.00" LG
2	2	73228	HANGER: DIA.(9.5mm).38 X 12.00" LG
3	2	94273	ISOLATOR: 2.27 X 2.91 X 1.30"

Borla Performance - Bill of Materials PN-60578

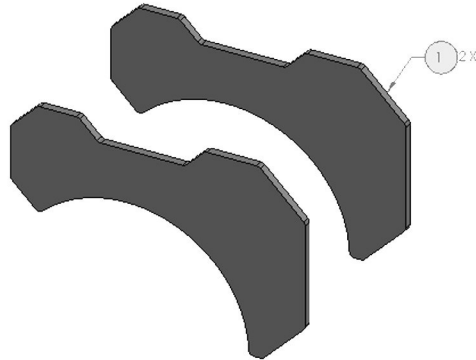

60578 2.25" Diameter Tube Brackets

ITEM NO.	QTY.	PART NUMBER	DESCRIPTION
1	2	22462	Ø2.25" TUBE BRACKET

Borla Performance - Bill of Materials PN-60579

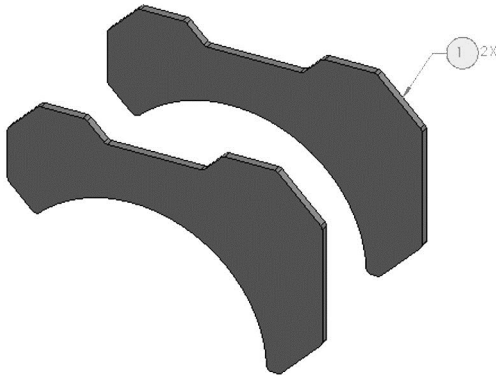

60579 2.50" Diameter Tube Brackets

ITEM NO.	QTY.	PART NUMBER	DESCRIPTION
1	2	22463	Ø2.50" TUBE BRACKET

Borla Performance - Bill of Materials PN-60580

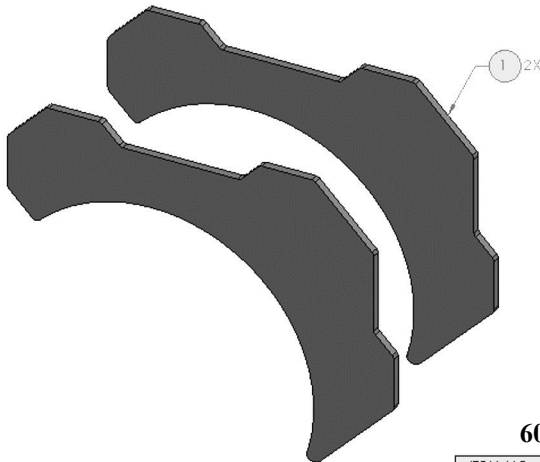

60580 3.00" Diameter Tube Brackets

ITEM NO.	QTY.	PART NUMBER	DESCRIPTION
1	2	22464	Ø3.00" TUBE BRACKET

ENDPLATE BRACKET KIT INSTALLATION

The Borla CrateMuffler™ Endplate Bracket Kit allow the fabricator to create a service-removable hanger system. This approach also allows unlimited customization (by the customer) in color-matching or polishing components for builders looking for creative detailing.

Borla Endplate Brackets bolt directly to the Borla CrateMuffler™ Endplates with slip-on U-Nuts and M6 bolts/washers. They can be rotated 90-degrees (4-positions) on **Center-Exit** Borla CrateMuffler™ allowing design flexibility. (*Note: Endplate Brackets have (1) single-position on Offset-Exit Borla CrateMuffler™.*)

Hangers are welded to Borla Endplate Brackets; hangers are inserted into rubber isolators (kit available separately, PN-60582). This system allows the fabricator to complete a styled hanger tailored to the vehicle.

RECOMMENDED HANGER WELDS for a CENTER-EXIT ENDPLATE BRACKET

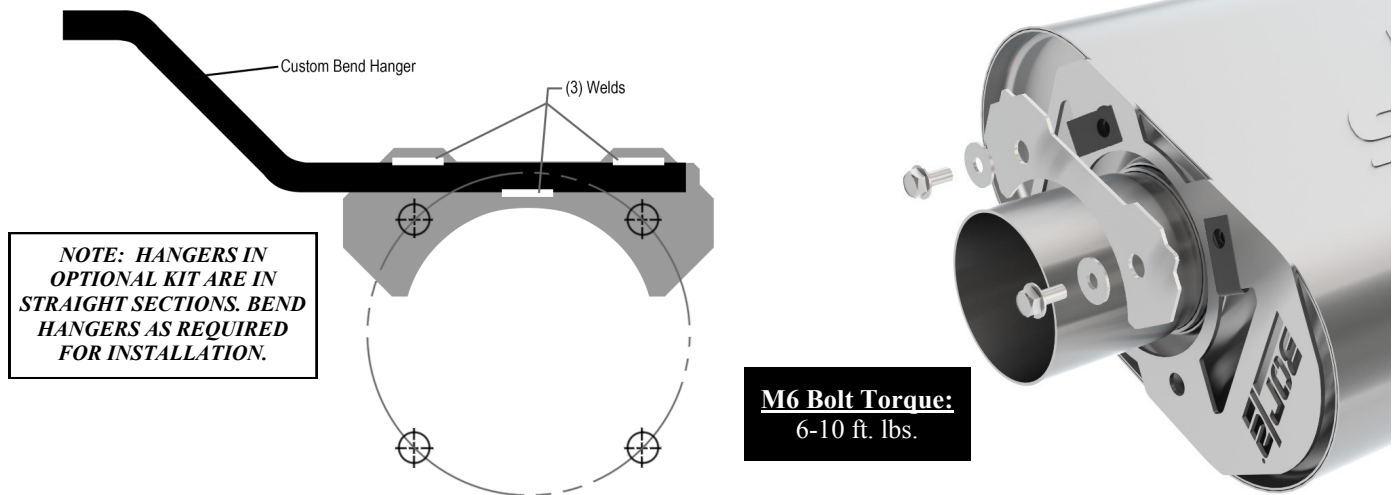

RECOMMENDED HANGER WELDS for a OFFSET-EXIT ENDPLATE BRACKET

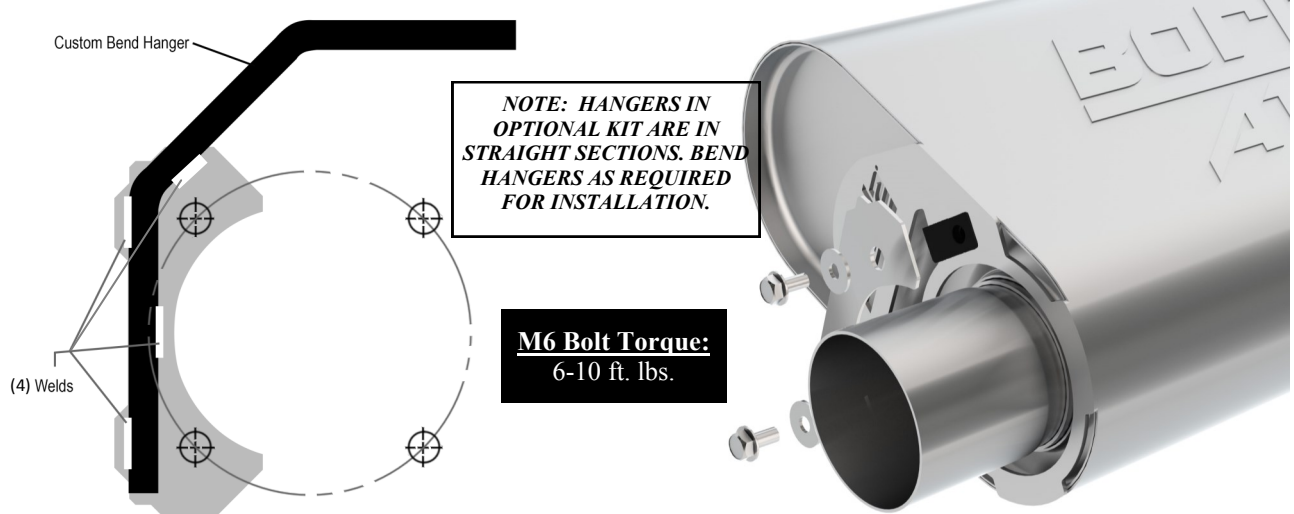

8-PIECE BRACKET KIT

The Borla 8-Piece Bracket Kit is designed to compliment Borla Endplate Brackets (PN-60581) and Borla Tubing Brackets (PNs 60578, 60579, or 60580) which completes the Borla CrateMuffler™ system. This system enables the fabricator to design a styled hanger tailored to the vehicle.

TYPICAL HANGER BEND LAYOUT - CENTER-EXIT CrateMuffler™ (LEFT-SIDE)

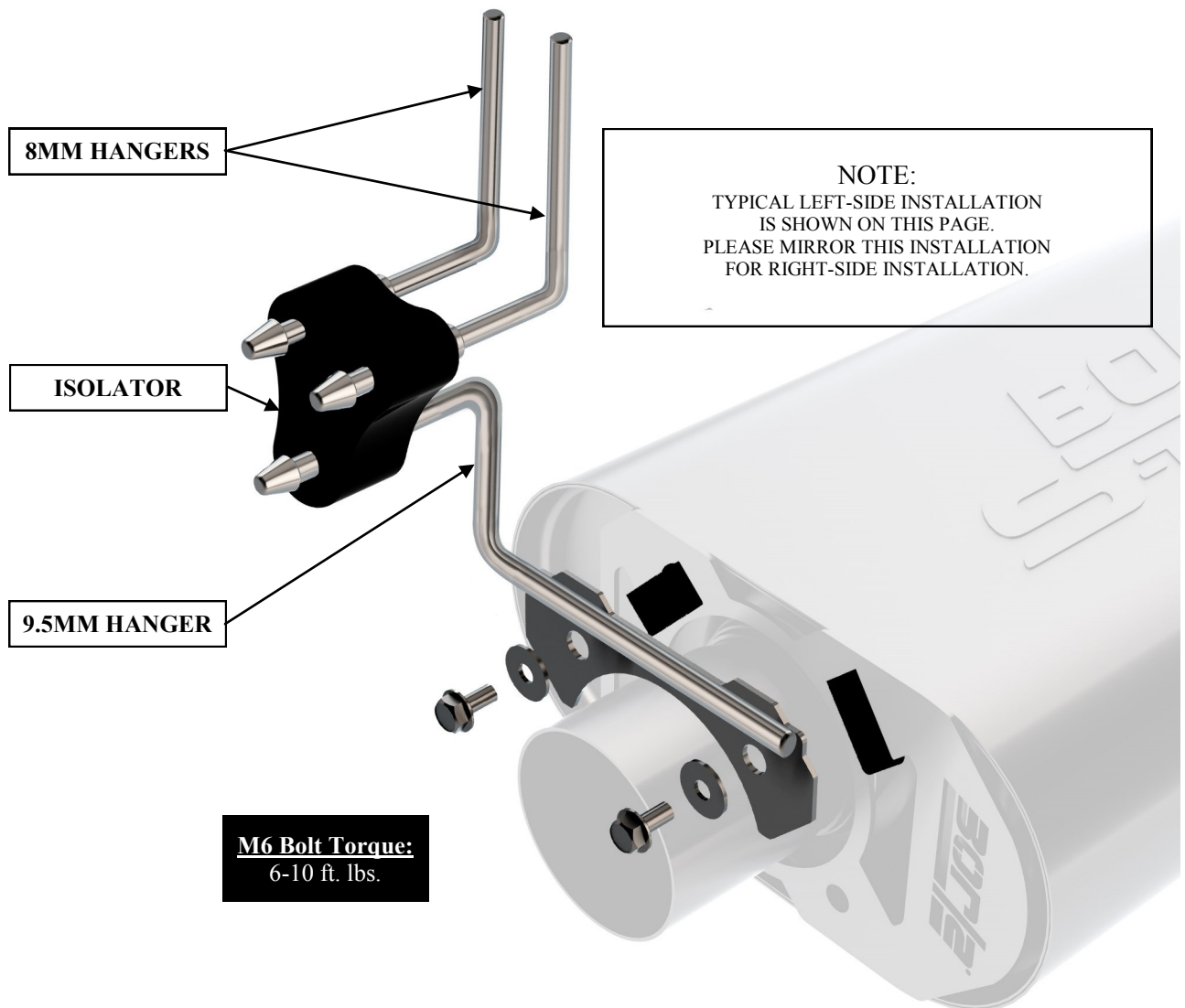

NOTE: HANGERS IN OPTIONAL KIT ARE IN STRAIGHT SECTIONS. BEND HANGERS AS REQUIRED FOR INSTALLATION.

TUBE BRACKETS

Borla Tube Brackets compliment Borla CrateMuffler™ aesthetics. They require less time to install (compared to bending hanger rod to match tubing diameter) and with some creativity, there is flexibility to create a custom look.

Exhaust tubing is secured with welded Borla Tube Brackets, welded hangers inserted into rubber isolators (kit available separately, PN-60582). This system allows the fabricator to complete a styled hanger tailored to the vehicle.

(RECOMMENDED) MINIMUM HANGER WELD LOCATIONS (BACK-SIDE)

60578 (2.25") & 60579 (2.50")

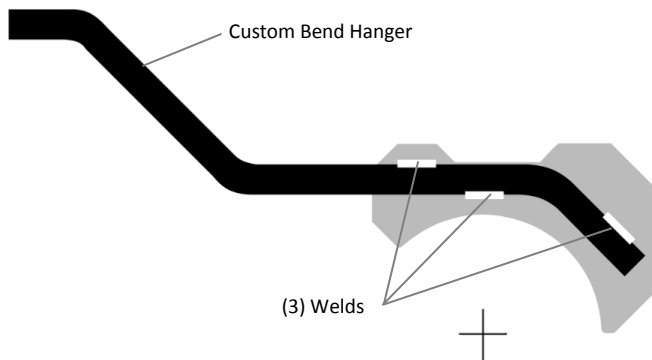

60580 (3.00")

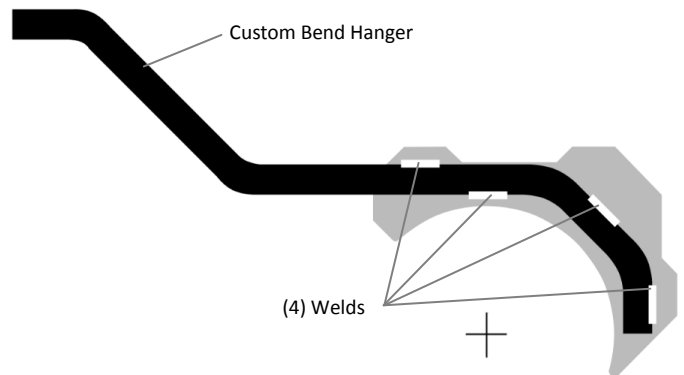

NOTE: HANGERS IN OPTIONAL KIT ARE IN STRAIGHT SECTIONS. BEND HANGERS AS REQUIRED FOR INSTALLATION.

FRONT-SIDE WELD EXAMPLE

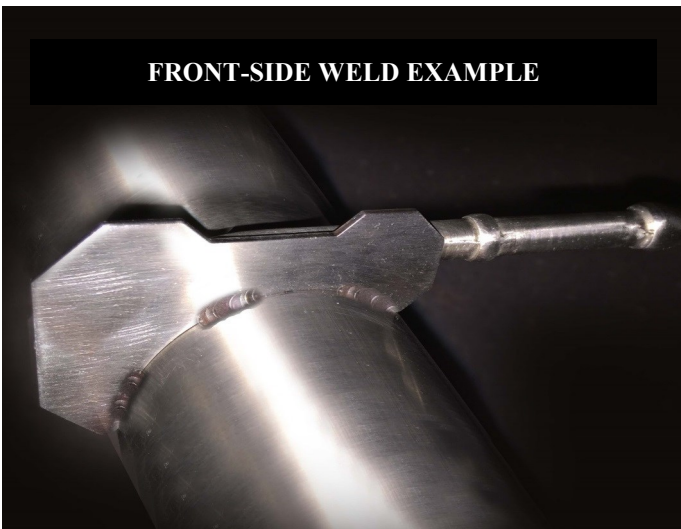

BACK-SIDE WELD EXAMPLE

