

Exhaust Component Installation for the Kia Stinger PN-20165



******* Please compare the parts in the box with the bill of materials provided *****
to assure that you have all the parts necessary for this installation.**

These instructions have been written to help you with the installation of your Borla Performance Exhaust Component. Please read this document completely before beginning the installation of your system.

Thank you for purchasing a Borla Performance Exhaust Component.

Borla Performance Exhaust Component (PN-20165) is designed to compliment your Borla Catback exhaust System replacing the valence tips on the Kia Stinger, 3.3TT or 2.0T engines.

Borla Performance Industries recommends that an exhaust shop or professional after market parts installer, who has all the necessary equipment, tools and experienced personnel needed for proper installation, should perform the installation of this system. However, if you decide to perform the installation, we recommend someone should help you. Ensure the installer uses all under car safety precautions including eye protection.

Please take time to read and understand the following...

By installing your Borla Performance Exhaust Component, you indicate that you have read this document and you agree with the terms stated below.

It is the responsibility of the purchaser to follow all installation instruction guidelines and safety procedures supplied with your Borla Performance Exhaust Component.

Borla Performance Industries assumes no responsibility for damages occurring from misuse, abuse, improper installation, improper operation, lack of responsible care, or all previously stated reasons resulting from incompatibility with other manufacturer's products and/or systems.

Minimum Required Tool List:

TOOLS:

1. 3/8” Drive Ratchet
2. 3/8” Drive Extension 3”
3. 15mm Deep Well Socket
4. 10mm Socket
5. 10mm End Wrench
6. Philips Screwdriver

SHOP SUPPLIES:

- 1 Spray Lubricant

Borla Performance - Bill of Materials

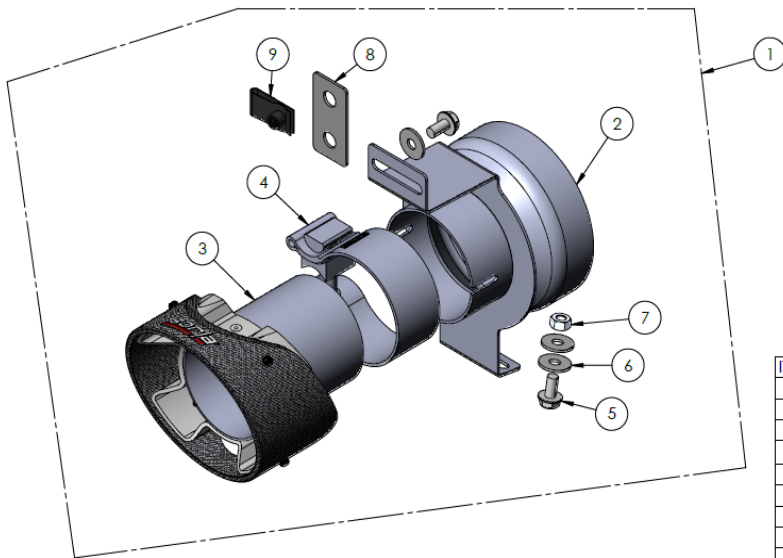

20165

ITEM NO.	PART NUMBER	DESCRIPTION	QTY
1	56718	CARBON FIBER SINGLE TIP	4
2	56719	BRACKET ASSEMBLY	4
3	480242	TIP ASSEMBLY	4
4	90113	S/S ACCUSEAL CLAMP Ø2.50	4
5	92244444	BOLT/SCREW-EXH MANIF H/SHLD	8
6	92039	Flat Washer: M6 Screw Size, 18mm OD	12
7	93004	NUT: HXHD, M6 X 1.00" PITCH, DIN 934	4
8	72396	EXTENSION PLATE: 1.00 X 2.00 X .06" THK	4
9	93077	Clip-on Nut: M6 Size, 1mm Pitch	4

Caution!!! *Never work on a hot exhaust system. Serious injury in the form of burns can result if the vehicle has been in use and the exhaust system is hot, allow vehicle to cool for at least 1 hour. Always wear eye protection when working under any vehicle.*

Note: *It is our recommendation that you use a hoist or hydraulic lift to facilitate the installation of your new Borla Performance Exhaust System.*

Taking all under car safety precautions, lift the vehicle using a hoist or hydraulic lift. Once this has been done, you may begin the removal of your old exhaust system from your vehicle.

Note: *Before removing the original exhaust system from your vehicle, please compare the parts you have received with the bill of materials provided on the previous page to assure that you have all the parts necessary for the installation of your new Borla Performance Exhaust System.*

Note: *With a used vehicle, we suggest a penetrating spray lubricant to be applied liberally to all exhaust fasteners and allowing a significant period of time for the chemical to lubricate the threads before attempting to disassemble.*

Original System Removal

NOTE: *Both rear mufflers need to be removed from vehicle prior to installation.*

1. Lubricated all hangers, rubber isolator, bolts and nuts.
2. Carefully loosen and remove hardware on flanges on rear muffler. Loosen and remove the hardware on the cross-brace. Keep the hardware for reinstallation of your new Borla system. (See Fig. 1)
3. Use a muffler stand or an additional person to hold the front exhaust assembly. Remove hangers from rubber isolators and carefully remove the left-side and right-side rear mufflers from the vehicle. (See Fig. 2 & 3)
4. Starting on the left-side tip bracket assembly, remove (2) top fasteners and (2) bottom fasteners as shown. Keep the top (2) fasteners for reinstallation. (See Figs. 4 & 5)
5. Remove left-side tip bracket assembly from vehicle.
6. Repeat STEP 4-5 to remove the right-side tip bracket assembly.

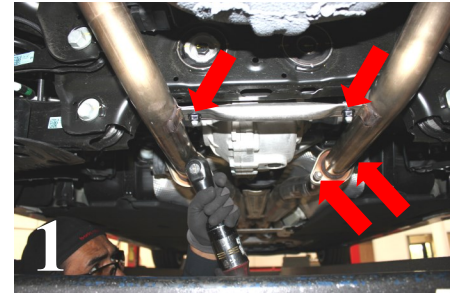

Borla Performance Exhaust Component Installation

*NOTE: **Bracket Assemblies** install separately (unlike the factory 1-piece bracket) on the inside of the valence. The **Carbon Fiber Tip Assembly** installs from the outside rear of the vehicle.*

1. Starting on the inside (left-side) of valence, insert and orient a **Clamp** on the tube of the **Bracket Assembly** and place the **Bracket Assembly** to the inside of the valence. (See Fig. 7)
2. Use original screw for the top of **Bracket Assembly** (See Fig. 8A) Do not tighten hardware.

NOTE: Use EXTENSION PLATE & PROVIDED HARDWARE installed for 2.0T vehicle. Do not tighten hardware. (See Fig. 8B)

3. Install provided **M6 Nut-Bolt** for the lower **Bracket Assembly**. Install both inside & outside **Bracket Assemblies** to left-hand valence. Do not tighten hardware. (See Fig. 9)
4. Carefully insert the **Tip Assembly** (from the outside) through the valence, through the **Clamp** and into the **Bracket Assembly**. Check orientation of the tip and gently snug the tip to the valence. Install both inside and outside **Tip Assemblies**. Do not tighten hardware. (See Fig. 10)
5. Repeat STEPS 1-2 for the right-side valence **Bracket Assemblies** & **Tip Assembly**.
6. Re-install left-side and right-side rear mufflers to vehicle.
7. Check your exhaust system for proper clearance under the vehicle and also for tip alignment to muffler outlets. Carefully tighten **Clamp** hardware bolts being mindful that the tips need to point straight back and centered to the muffler outlets. Orient position of bolt (on supplied clamps) and tighten to 35 ft. lbs. torque. (See Fig. 11)
8. Before starting your vehicle, make sure to check all wires, hoses, brake lines, body parts and tires for safe clearance from the exhaust system.

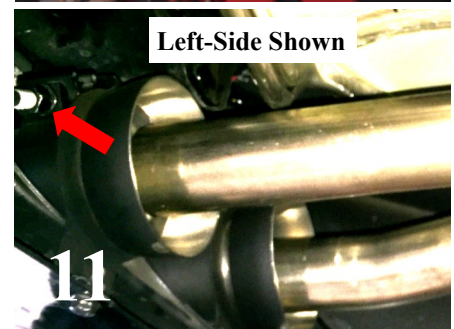
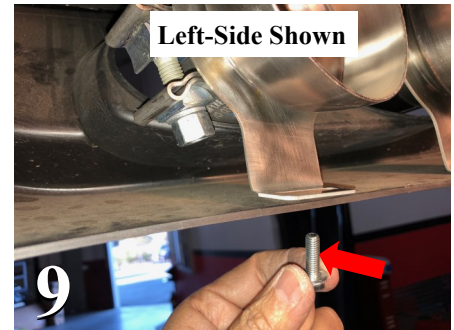

WARNING: Use extreme caution during installation. Torque all fasteners according to manufacturer's torque values and tightening sequence. DO NOT use air impact tools to tighten fasteners on Borla Performance Exhaust Systems. Use of such tools may result in bent flanges or gasket contact areas leading to exhaust leaks.

NOTE: When you first start your vehicle after the installation of your new Borla Performance Exhaust System, there may be some smoke and fumes coming from the system. This is a protective oil based coating used in the manufacturing of mandrel bent performance exhaust tubing. This is not a problem and will disappear within a very short period of time after the exhaust has reached normal operating temperatures.