

Installation Guide for Ford Mustang Shelby GT500 PNs 140837, 140837BC, 140837CF



******* Please compare the parts in the box with the bill of materials provided *****
to assure that you have all the parts necessary for this installation.**

These instructions have been written to help you with the installation of your Borla Performance Exhaust System. Please read this document completely before beginning the installation of your system.

Thank you for purchasing a Borla Performance Exhaust System.

These Borla Performance Cat-Back™ Exhaust Systems (PNs 140837, 140837BC, 140837CF) are designed for the Ford Mustang Shelby GT500 equipped with a 5.2L supercharged V8 engine and automatic transmission.

Borla Performance Industries recommends that an exhaust shop or professional after market parts installer, who has all the necessary equipment, tools and experienced personnel needed for proper installation, should perform the installation of this system. However, if you decide to perform the installation, we recommend someone should help you. Ensure the installer uses all under car safety precautions including eye protection.

Please take time to read and understand the following...

By installing your Borla Performance Exhaust System, you indicate that you have read this document and you agree with the terms stated below.

It is the responsibility of the purchaser to follow all installation instruction guidelines and safety procedures supplied with your Borla Performance Exhaust System.

Borla Performance Industries assumes no responsibility for damages occurring from misuse, abuse, improper installation, improper operation, lack of responsible care, or all previously stated reasons resulting from incompatibility with other manufacturer's products and/or systems.

Included with your Borla Performance Exhaust System is a warranty card. Please read it carefully before you begin any work on your vehicle. If you should have any questions regarding our warranty policy, installation, or any other matter pertaining to your new Borla Performance Exhaust System, please give us a call at the number provided on the warranty card.

Minimum Required Tool List:

TOOLS:

1. 3/8” drive ratchet
2. 3/8” drive extension 3”
3. 15mm deep well socket
4. 13mm socket
5. 10mm socket
6. 7mm socket
7. Pry bar

SHOP SUPPLIES:

1. Spray lubricant

Borla Performance - Bill of Materials

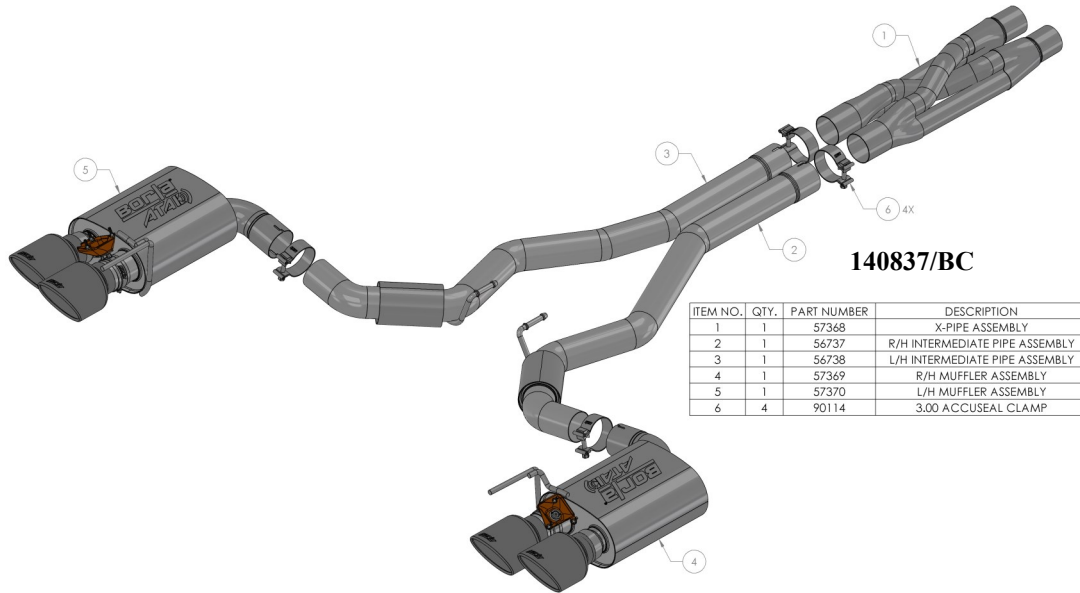

140837/BC

ITEM NO.	QTY.	PART NUMBER	DESCRIPTION
1	1	57368	X-PIPE ASSEMBLY
2	1	56737	R/H INTERMEDIATE PIPE ASSEMBLY
3	1	56738	L/H INTERMEDIATE PIPE ASSEMBLY
4	1	57369	R/H MUFFLER ASSEMBLY
5	1	57370	L/H MUFFLER ASSEMBLY
6	4	90114	3.00 ACCUSEAL CLAMP

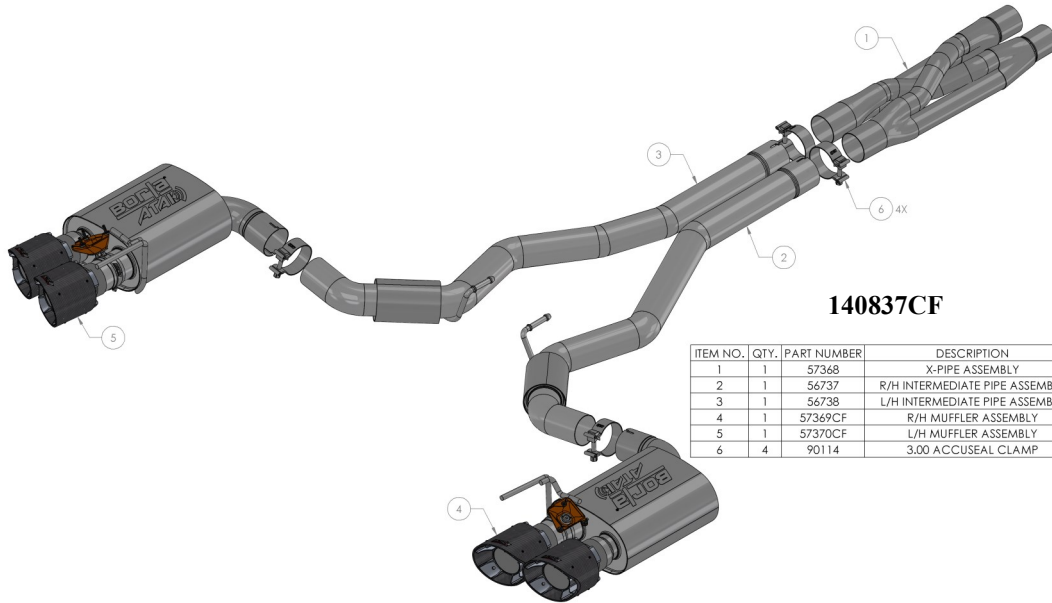

140837CF

ITEM NO.	QTY.	PART NUMBER	DESCRIPTION
1	1	57368	X-PIPE ASSEMBLY
2	1	56737	R/H INTERMEDIATE PIPE ASSEMBLY
3	1	56738	L/H INTERMEDIATE PIPE ASSEMBLY
4	1	57369CF	R/H MUFFLER ASSEMBLY
5	1	57370CF	L/H MUFFLER ASSEMBLY
6	4	90114	3.00 ACCUSEAL CLAMP

Caution!!! Never work on a hot exhaust system. Serious injury in the form of burns can result if the vehicle has been in use and the exhaust system is hot, allow vehicle to cool for at least 1 hour. Always wear eye protection when working under any vehicle.

Note: It is our recommendation that you use a hoist or hydraulic lift to facilitate the installation of your new Borla Performance Exhaust System.

Taking all under car safety precautions, lift the vehicle using a hoist or hydraulic lift. Once this has been done, you may begin the removal of your old exhaust system from your vehicle.

Note: Before removing the original exhaust system from your vehicle, please compare the parts you have received with the bill of materials provided on the previous page to assure that you have all the parts necessary for the installation of your new Borla Performance Exhaust System.

Note: With a used vehicle, we suggest a penetrating spray lubricant to be applied liberally to all exhaust fasteners and allowing a significant period of time for the chemical to lubricate the threads before attempting to disassemble.

Original Exhaust System Removal

1. Disconnect left and right side wire harness by pulling the pin and sliding out from electrical assembly (fig. 1).
2. Beginning on the left side of the vehicle, use a flat blade screwdriver to pull the clip and disengage it from the pipe (fig. 2)
3. REPEAT STEP 2 for the right side of the vehicle. Loosen the 4 clamp fasteners and retain the original clamps for re-installation.
4. Loosen the 2 factory bolts on both rear left-side and right-side rubber brackets. Leave rubber isolator assemblies on the muffler hangers (fig. 3).
5. Using a muffler stand or an additional person hold the muffler assembly in position, and carefully remove from vehicle (fig. 4).
6. Factory exhaust system removed (fig. 5).

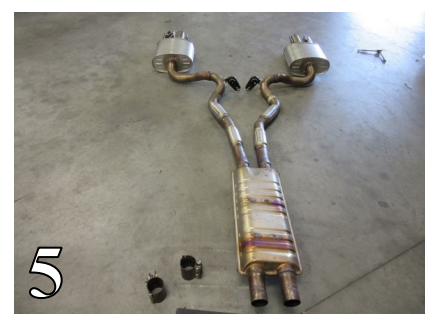
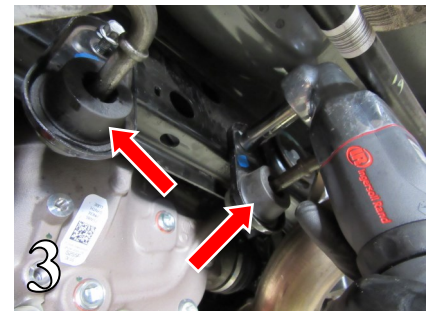
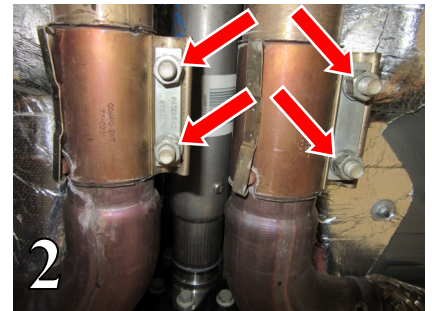

Borla Performance Cat-Back™ Exhaust System Installation

1. Orient the components on the floor referencing the drawing on page 2.
2. Transfer both rubber isolators from factory exhaust to the Borla intermediate pipes noting the correct orientation (fig. 6).
3. Slide the adapter pipes into the Borla X-pipe assembly using two 3" clamps and fasten the components together (fig. 7).
4. Install the Borla R/H intermediate pipe assembly inserting the hanger hook into the rubber isolator (fig. 9).
5. REPEAT STEP 5 for the L/H intermediate pipe assembly.

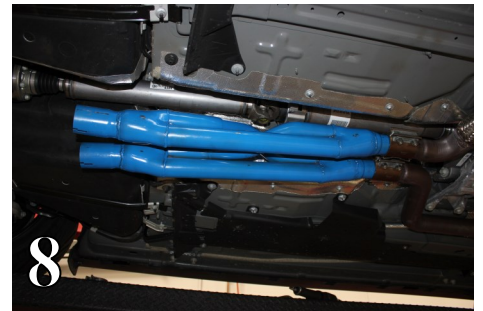

WARNING: Use extreme caution during installation. Torque all fasteners according to manufacturer's torque values and tightening sequence. **DO NOT** use air impact tools to tighten fasteners on Borla Performance Exhaust Systems. Use of such tools may result in bent flanges or gasket contact areas leading to exhaust leaks.

NOTE: When you first start your vehicle after the installation of your new Borla Performance Exhaust System, there may be some smoke and fumes coming from the system. This is a protective oil based coating used in the manufacturing of mandrel bent performance exhaust tubing. This is not a problem and will disappear within a very short period of time after the exhaust has reached normal operating temperatures.

Borla Performance Cat-Back™ Exhaust System Installation (Cont'd)

NOTE: The actuator gear on the electronic actuator needs to be aligned to the valve slot for proper engagement. Improper function of the valves, a CEL, or damage can occur if these aren't aligned.

- A. The valve plate needs to be in open position. Please rotate the valve prior to mounting factory actuator to R/H Borla muffler assembly (fig. 10).
- B. Orient the actuator gear to the valve slot then position the factory actuator bolt holes. Reuse 3 factory bolt/washer/nut assemblies in securing the factory actuator to the Borla muffler assembly (figs. B, C, D).
- C. Verify alignment of the actuator gear to the valve slot. Tighten the nut/bolt assemblies to 8-9 ft. lb. torque (fig. E).
- D. REPEAT STEPS A, B, & C for the L/H Borla muffler assembly factory actuator installation.
- E. **Reconnect the wire harnesses to the factory actuators, both left and right sides.**

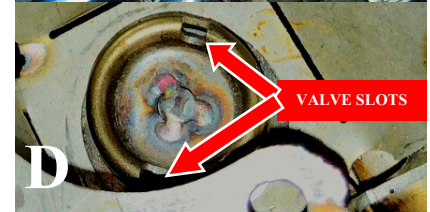
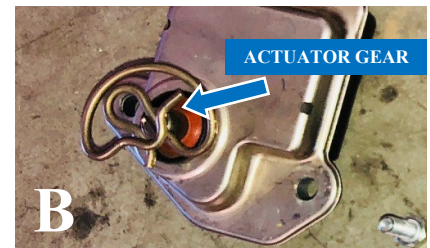
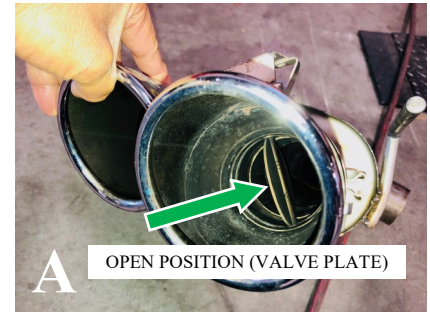

WARNING: Use extreme caution during installation. Torque all fasteners according to manufacturer's torque values and tightening sequence. **DO NOT** use air impact tools to tighten fasteners on Borla Performance Exhaust Systems. Use of such tools may result in bent flanges or gasket contact areas leading to exhaust leaks.

NOTE: When you first start your vehicle after the installation of your new Borla Performance Exhaust System, there may be some smoke and fumes coming from the system. This is a protective oil based coating used in the manufacturing of mandrel bent performance exhaust tubing. This is not a problem and will disappear within a very short period of time after the exhaust has reached normal operating temperatures.

Borla Performance Cat-Back™ Exhaust System Installation (Cont'd)

6. Starting on the left side of the vehicle, place a clamp on the L/H Borla muffler assembly inlet pipe and insert the inlet pipe into the L/H Borla intermediate pipe assembly. Insert the hanger into the rear rubber isolator (fig. 10). Do not tighten the clamps yet.
7. REPEAT STEP 7 for the R/H Borla muffler assembly. Do not tighten the clamps yet.
8. Check your exhaust system for proper clearance under the vehicle and also for tip alignment (fig. 11).
9. Starting at front flanges and moving to rear of vehicle, tighten flange hardware bolts. Orient position of bolt (on supplied clamps) between (not over) pipe notches and tighten to 35 ft. lbs. torque (fig. 12).
10. Before starting your vehicle, make sure to check all wires, hoses, brake lines, body parts and tires for safe clearance from the exhaust system.
11. Start vehicle and check for any leaks. If any leaks are found, determine cause (such as loose or incorrectly positioned clamp) and repair as necessary.

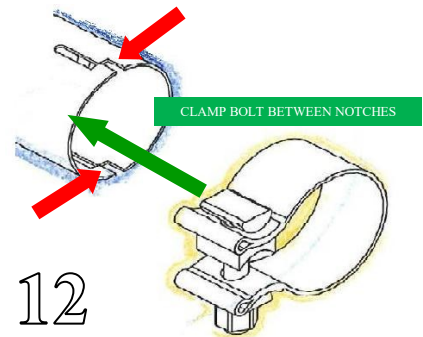

WARNING: Use extreme caution during installation. Torque all fasteners according to manufacturer's torque values and tightening sequence. **DO NOT** use air impact tools to tighten fasteners on Borla Performance Exhaust Systems. Use of such tools may result in bent flanges or gasket contact areas leading to exhaust leaks.

NOTE: When you first start your vehicle after the installation of your new Borla Performance Exhaust System, there may be some smoke and fumes coming from the system. This is a protective oil based coating used in the manufacturing of mandrel bent performance exhaust tubing. This is not a problem and will disappear within a very short period of time after the exhaust has reached normal operating temperatures.