

## Installation Guide for Ford Explorer XLT & Limited PNs 140824, 140825, 140825BC



**\*\*\*\*\* Please compare the parts in the box with the bill of materials provided \*\*\*\*\*  
to ensure that you have all the parts necessary for this installation.**

These instructions have been written to help you with the installation of your Borla Performance exhaust system. Please read this document completely before beginning the installation of your system.

Thank you for purchasing a Borla Performance Cat-Back™ exhaust system.

Borla Performance Cat-Back™ exhaust system PN 140824 is designed for the Ford Explorer XLT, equipped with a 2.3L turbocharged I4 engine and 2WD or AWD automatic transmission.

Borla Performance Cat-Back™ exhaust system PNs 140825 and 140825BC are designed for the Ford Explorer Limited, equipped with a 2.3L turbocharged I4 engine and 2WD or AWD automatic transmission.

Borla Performance Industries recommends that an exhaust shop or professional after market parts installer, who has all the necessary equipment, tools and experienced personnel needed for proper installation, should perform the installation of this system. However, if you decide to perform the installation, we recommend someone should help you. Ensure the installer uses all under car safety precautions including eye protection.

*Please take time to read and understand the following...*

By installing your Borla Performance exhaust system, you indicate that you have read this document and you agree with the terms stated below.

It is the responsibility of the purchaser to follow all installation instruction guidelines and safety procedures supplied with your Borla Performance exhaust system.

Borla Performance Industries assumes no responsibility for damages occurring from misuse, abuse, improper installation, improper operation, lack of responsible care, or all previously stated reasons resulting from incompatibility with other manufacturer's products and/or systems.

Included with your Borla Performance exhaust system is a warranty card. Please read it carefully before you begin any work on your vehicle. If you should have any questions regarding our warranty policy, installation, or any other matter pertaining to your new Borla Performance exhaust system, please give us a call at the number provided on the warranty card.

**Minimum Required Tool List:**

**TOOLS:**

1. 3/8" drive ratchet
2. 3/8" drive extension 6"
3. 15mm socket
4. 10mm socket

**SHOP SUPPLIES:**

1. Spray lubricant

**Borla Performance - Bill of Materials**

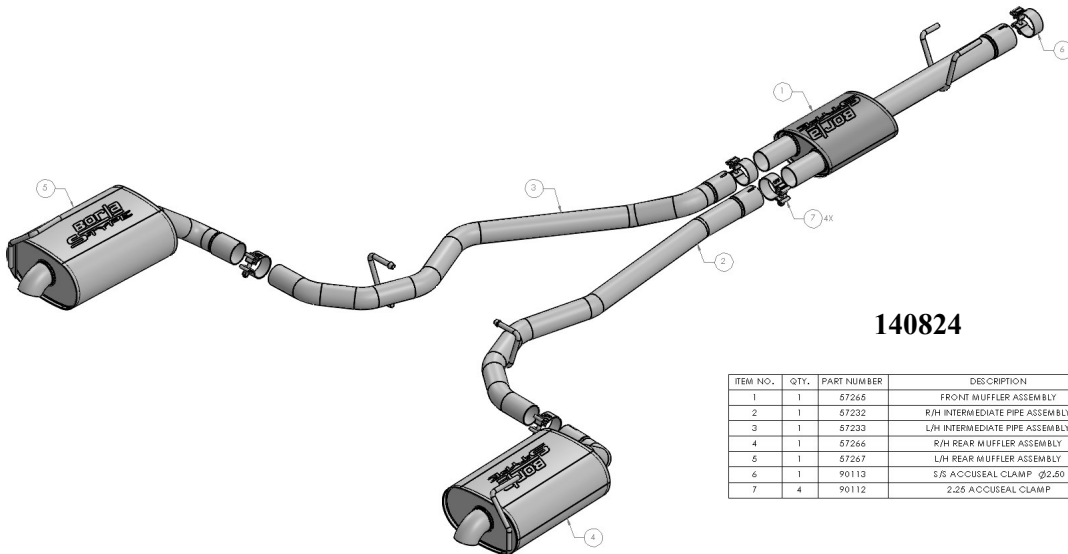

**140824**

ITEM NO.	QTY.	PART NUMBER	DESCRIPTION
1	1	57265	FRONT MUFFLER ASSEMBLY
2	1	57232	R/H INTERMEDIATE PIPE ASSEMBLY
3	1	57233	L/H INTERMEDIATE PIPE ASSEMBLY
4	1	57266	R/H REAR MUFFLER ASSEMBLY
5	1	57267	L/H REAR MUFFLER ASSEMBLY
6	1	90113	S/S ACCUSEAL CLAMP Ø2.50
7	4	90112	2.25 ACCUSEAL CLAMP

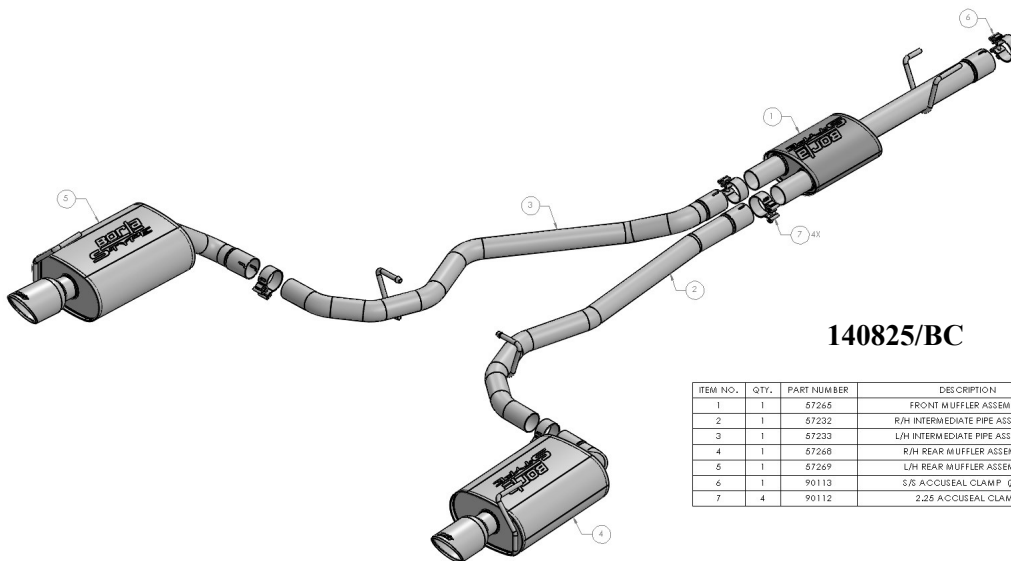

**140825/BC**

ITEM NO.	QTY.	PART NUMBER	DESCRIPTION
1	1	57265	FRONT MUFFLER ASSEMBLY
2	1	57232	R/H INTERMEDIATE PIPE ASSEMBLY
3	1	57233	L/H INTERMEDIATE PIPE ASSEMBLY
4	1	57268	R/H REAR MUFFLER ASSEMBLY
5	1	57269	L/H REAR MUFFLER ASSEMBLY
6	1	90113	S/S ACCUSEAL CLAMP Ø2.50
7	4	90112	2.25 ACCUSEAL CLAMP

**Caution!!!** *Never work on a hot exhaust system. Serious injury in the form of burns can result if the vehicle has been in use and the exhaust system is hot, allow vehicle to cool for at least 1 hour. Always wear eye protection when working under any vehicle.*

**Note:** *It is our recommendation that you use a hoist or hydraulic lift to facilitate the installation of your new Borla Performance Exhaust System.*

**Taking all under car safety precautions, lift the vehicle using a hoist or hydraulic lift. Once this has been done, you may begin the removal of your old exhaust system from your vehicle.**

**Note:** *Before removing the original exhaust system from your vehicle, please compare the parts you have received with the bill of materials provided on the previous page to assure that you have all the parts necessary for the installation of your new Borla Performance Exhaust System.*

**Note:** *With a used vehicle, we suggest a penetrating spray lubricant to be applied liberally to all exhaust fasteners and allowing a significant period of time for the chemical to lubricate the threads before attempting to disassemble.*

## Original Exhaust System Removal

1. Lubricate all hangers, rubber isolators, bolts and nuts.
2. Loosen the bolt on the rear muffler hanger brackets (figs. 1, 2).
3. Remove the over-axle pipe hangers from their rubber isolators (fig. 3).
4. Loosen the nuts on the front muffler clamps (fig. 4).
5. Using a muffler stand or an additional person, carefully remove the original exhaust system from the vehicle (fig. 5).
6. Original exhaust system removed.

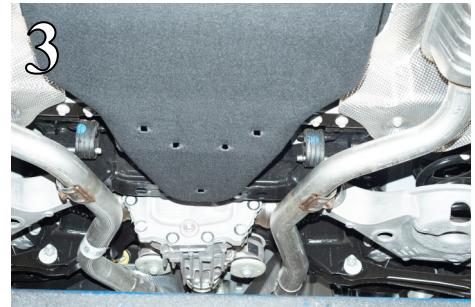

**Caution!!!** *Never work on a hot exhaust system. Serious injury in the form of burns can result. If the vehicle has been in use and the exhaust system is hot, allow vehicle to cool for at least 1 hour. Always wear eye protection when working under any vehicle.*

**Note:** *It is our recommendation that you use a hoist or hydraulic lift to facilitate the installation of your new Borla Performance Exhaust System.*

**Taking all under car safety precautions, lift the vehicle using a hoist or hydraulic lift. Once this has been done, you may begin the removal of your old exhaust system from your vehicle.**

**Note:** *Before removing the original exhaust system from your vehicle, please compare the parts you have received with the bill of materials provided on the previous page to assure that you have all the parts necessary for the installation of your new Borla Performance Exhaust System.*

**Note:** *With a used vehicle, we suggest a penetrating spray lubricant to be applied liberally to all exhaust fasteners and allowing a significant period of time for the chemical to lubricate the threads before attempting to disassemble.*

## Original Exhaust System Removal

7. With the original exhaust on the shop floor, remove the rear muffler hanger brackets. **Note which side each bracket belongs to, as they will be installed the on the opposite side in order to mount your Borla Performance exhaust system (figs. 6, 7).**



## Borla Performance Cat-Back™ Exhaust System Installation

1. Orient the components on shop floor according to the bill of materials drawing provided on page 2 or 3.
2. Place a clamp over the inlet of the front muffler assembly.
3. Connect the inlet of the front muffler assembly to the vehicle's front pipe (fig. 8). Do not tighten the clamp yet.
4. Insert the front muffler assembly's hangers into their rubber isolators.
5. Slide a clamp over the inlet of the L/H over-axle pipe assembly.
6. Connect the L/H over-axle pipe assembly to the outlet of the front muffler assembly (fig. 9). Do not tighten the clamp yet.
7. Repeat steps 5 and 6 for the R/H over-axle pipe assembly (figs. 10, 11).
8. Slide a clamp over the inlet of the L/H rear muffler assembly.
9. **Move the R/H rear hanger bracket to the L/H rear muffler assembly (figs. 12, 13).**
10. Repeat steps 8 and 9 for the R/H muffler assembly, using the L/H rear hanger bracket.

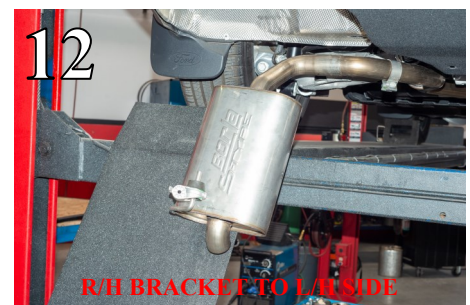
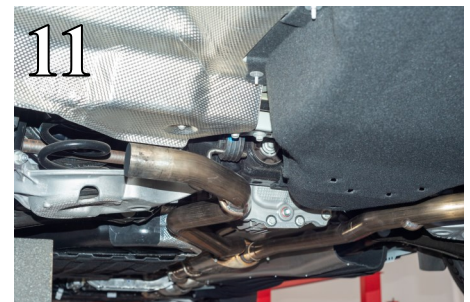

**WARNING:** Use extreme caution during installation. Torque all fasteners according to manufacturer's torque values and tightening sequence. **DO NOT** use air impact tools to tighten fasteners on Borla Performance Exhaust Systems. Use of such tools may result in bent flanges or gasket contact areas leading to exhaust leaks.

**NOTE:** When you first start your vehicle after the installation of your new Borla Performance Exhaust System, there may be some smoke and fumes coming from the system. This is a protective oil based coating used in the manufacturing of mandrel bent performance exhaust tubing. This is not a problem and will disappear within a very short period of time after the exhaust has reached normal operating temperatures.

## Borla Performance Cat-Back™ Exhaust System Installation Cont'd

11. Rotate the rear muffler assemblies up and tighten the bolt on the rear brackets (fig. 13).
12. Check your exhaust system for proper clearance under the vehicle and also for tip alignment. Starting at the front flanges and moving to the rear of vehicle, tighten the flange hardware/bolts. Orient the position of bolt (on supplied clamps) between (not over) pipe notches and tighten to 35 ft. lbs. torque (figs. 15-17).
13. Align tips and tighten hardware. Loosen clamps to rotate or slide pipe for better alignment.
14. Before starting your vehicle, make sure to check all wires, hoses, brake lines, body parts and tires for safe clearance from the exhaust system.
15. Start the vehicle and check for any leaks. If any leaks are found, determine cause (such as loose or incorrectly positioned clamp) and repair as necessary.

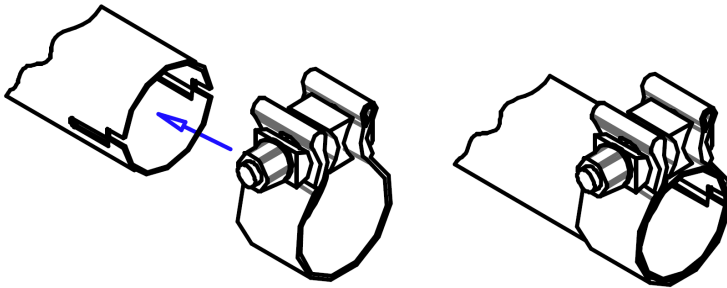

**WARNING:** Use extreme caution during installation. Torque all fasteners according to manufacturer's torque values and tightening sequence. **DO NOT** use air impact tools to tighten fasteners on Borla Performance Exhaust Systems. Use of such tools may result in bent flanges or gasket contact areas leading to exhaust leaks.

**NOTE:** When you first start your vehicle after the installation of your new Borla Performance Exhaust System, there may be some smoke and fumes coming from the system. This is a protective oil based coating used in the manufacturing of mandrel bent performance exhaust tubing. This is not a problem and will disappear within a very short period of time after the exhaust has reached normal operating temperatures.