

## Installation Guide for Jeep Gladiator PNs 140814CB, 140815CB, 140816CB



**\*\*\*\*\* Please compare the parts in the box with the bill of materials provided \*\*\*\*\*  
to ensure that you have all the parts necessary for this installation.**

These instructions have been written to help you with the installation of your Borla Performance exhaust system. Please read this document completely before beginning the installation of your system.

Thank you for purchasing a Borla Performance Cat-Back™ exhaust system.

These Borla Performance Cat-Back™ exhaust systems (PNs 140814CB, 140815CB, 140816CB) are designed for the Jeep Gladiator, equipped with a 3.6L V6 engine and 4X4 automatic or manual transmission.

Borla Performance Industries recommends that an exhaust shop or professional after market parts installer, who has all the necessary equipment, tools and experienced personnel needed for proper installation, should perform the installation of this system. However, if you decide to perform the installation, we recommend someone should help you. Ensure the installer uses all under car safety precautions including eye protection.

*Please take time to read and understand the following...*

By installing your Borla Performance exhaust system, you indicate that you have read this document and you agree with the terms stated below.

It is the responsibility of the purchaser to follow all installation instruction guidelines and safety procedures supplied with your Borla Performance exhaust system.

Borla Performance Industries assumes no responsibility for damages occurring from misuse, abuse, improper installation, improper operation, lack of responsible care, or all previously stated reasons resulting from incompatibility with other manufacturer's products and/or systems.

Included with your Borla Performance exhaust system is a warranty card. Please read it carefully before you begin any work on your vehicle. If you should have any questions regarding our warranty policy, installation, or any other matter pertaining to your new Borla Performance exhaust system, please give us a call at the number provided on the warranty card.

### Minimum Required Tool List:

#### TOOLS:

1. 3/8" drive ratchet
2. 3/8" drive extension 6"
3. 3/8" drive extension 3"
4. 17mm socket
5. 15mm socket
6. 13mm socket
7. 7/8" wrench

#### SHOP SUPPLIES:

1. Spray lubricant

### Borla Performance - Bill of Materials

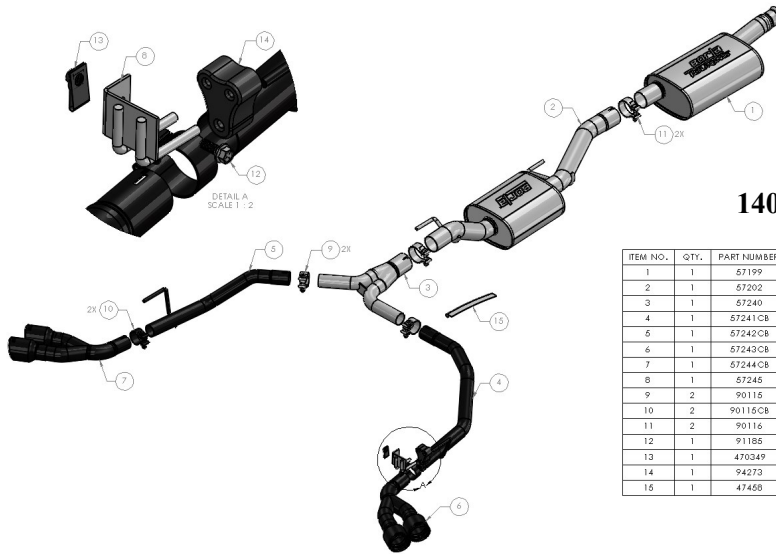

#### 140814CB

ITEM NO.	QTY.	PART NUMBER	DESCRIPTION
1	1	57199	FRONT MUFFLER ASSEMBLY
2	1	57202	REAR MUFFLER ASSEMBLY
3	1	57240	Y-PIPE ASSEMBLY
4	1	57241CB	R/H OVER-AXLE PIPE ASSEMBLY
5	1	57242CB	L/H OVER-AXLE PIPE ASSEMBLY
6	1	57243CB	R/H TAILPIPE ASSEMBLY
7	1	57244CB	L/H TAILPIPE ASSEMBLY
8	1	57245	HANGER/BRACKET ASSEMBLY
9	2	90115	S/S ACCUSEAL CLAMP Ø2.00
10	2	90115CB	S/S ACCUSEAL CLAMP Ø2.00
11	2	90116	S/S ACCUSEAL CLAMP: Ø2.75
12	1	91185	SCREW: FLNG., HWHD: .375" 16 THREAD, 1" LG.
13	1	470349	CLIP-ON NUT: .375" 16 THREAD
14	1	94273	ISOLATOR: 2.27 X 2.91 X 1.30"
15	1	47458	HEAT SHIELD: REFLEXWRAP 1463, 13MM X 254MM

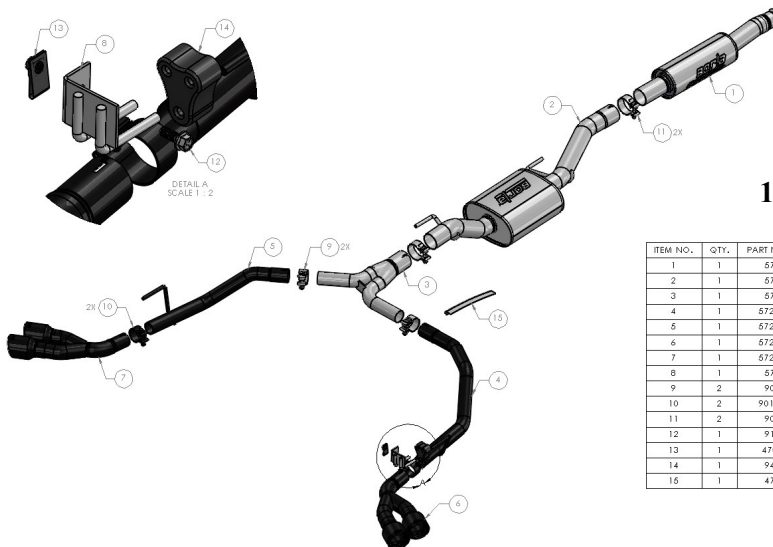

#### 140815CB

ITEM NO.	QTY.	PART NUMBER	DESCRIPTION
1	1	57200	FRONT MUFFLER ASSEMBLY
2	1	57202	REAR MUFFLER ASSEMBLY
3	1	57240	Y-PIPE ASSEMBLY
4	1	57241CB	R/H OVER-AXLE PIPE ASSEMBLY
5	1	57242CB	L/H OVER-AXLE PIPE ASSEMBLY
6	1	57243CB	R/H TAILPIPE ASSEMBLY
7	1	57244CB	L/H TAILPIPE ASSEMBLY
8	1	57245	HANGER/BRACKET ASSEMBLY
9	2	90115	S/S ACCUSEAL CLAMP Ø2.00
10	2	90115CB	S/S ACCUSEAL CLAMP Ø2.00
11	2	90116	S/S ACCUSEAL CLAMP: Ø2.75
12	1	91185	SCREW: FLNG., HWHD: .375" 16 THREAD, 1" LG.
13	1	470349	CLIP-ON NUT: .375" 16 THREAD
14	1	94273	ISOLATOR: 2.27 X 2.91 X 1.30"
15	1	47488	HEAT SHIELD: REFLEXWRAP 1463, 13MM X 254MM

#### INSTALLATION INSTRUCTIONS

Jeep Gladiator 3.6L PNs 140814CB, 140815CB, 140816CB

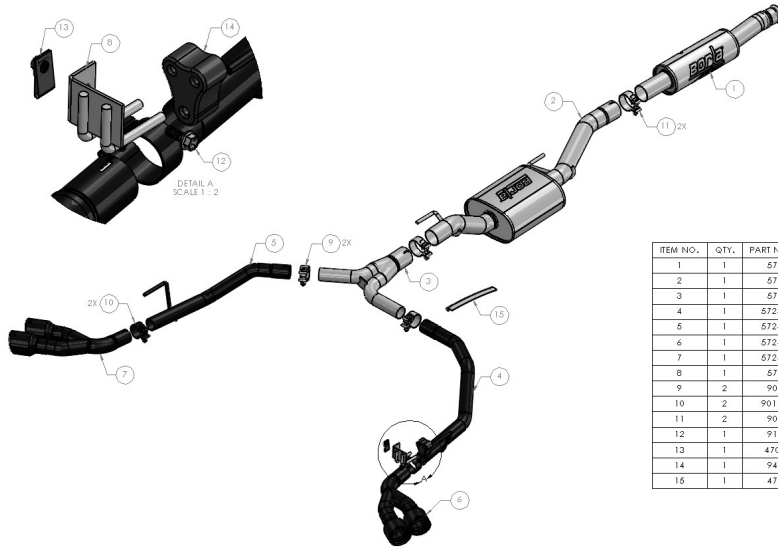

**140816CB**

ITEM NO.	QTY.	PART NUMBER	DESCRIPTION
1	1	57201	FRONT MUFFLER ASSEMBLY
2	1	57202	REAR MUFFLER ASSEMBLY
3	1	57240	Y-PIPE ASSEMBLY
4	1	57241CB	R/H OVER-AXLE PIPE ASSEMBLY
5	1	57242CB	L/H OVER-AXLE PIPE ASSEMBLY
6	1	57243CB	R/H TAILPIPE ASSEMBLY
7	1	57244CB	L/H TAILPIPE ASSEMBLY
8	1	57245	HANGER/RACKET ASSEMBLY
9	2	90115	5/8 ACQUISAL CLAMP Ø2.00
10	2	90115CB	5/8 ACQUISAL CLAMP Ø2.00
11	2	90116	5/8 ACQUISAL CLAMP Ø2.75
12	1	91185	SCREW/FLANG., HWHD., 3/75" 1/4 THREAD, 1" LG.
13	1	470349	CUP-ON NUT, 3/75" 1/4 THREAD
14	1	94273	ISOLATOR: 2.27 X 2.91 X 1.20"
15	1	47458	HEAT SHIELD: REFLEXWRAP 1463, 13MM X 254MM

**INSTALLATION INSTRUCTIONS**

Jeep Gladiator 3.6L PNs 140814CB, 140815CB, 140816CB

**Caution!!!** *Never work on a hot exhaust system. Serious injury in the form of burns can result if the vehicle has been in use and the exhaust system is hot, allow vehicle to cool for at least 1 hour. Always wear eye protection when working under any vehicle.*

*Note: It is our recommendation that you use a hoist or hydraulic lift to facilitate the installation of your new Borla Performance Exhaust System.*

*Taking all under car safety precautions, lift the vehicle using a hoist or hydraulic lift. Once this has been done, you may begin the removal of your old exhaust system from your vehicle.*

*Note: Before removing the original exhaust system from your vehicle, please compare the parts you have received with the bill of materials provided on the previous page to assure that you have all the parts necessary for the installation of your new Borla Performance Exhaust System.*

*Note: With a used vehicle, we suggest a penetrating spray lubricant to be applied liberally to all exhaust fasteners and allowing a significant period of time for the chemical to lubricate the threads before attempting to disassemble.*

## Original Exhaust System Removal

1. Lubricate all hangers, rubber isolators, bolts and nuts.
2. Make a cut directly behind the front muffler assembly so that the original exhaust system can be removed in two pieces (fig. 1).
3. Remove the bolts holding the rear muffler assembly hanger bracket (fig. 2). Keep the hardware for later reinstallation.
4. Remove the bolts holding the front of the rear muffler assembly hanger (fig. 3). Keep the hardware for later reinstallation.
5. Carefully remove the rear muffler assembly from the vehicle (fig. 4).
6. Rear muffler assembly and hanger brackets removed (fig. 5).

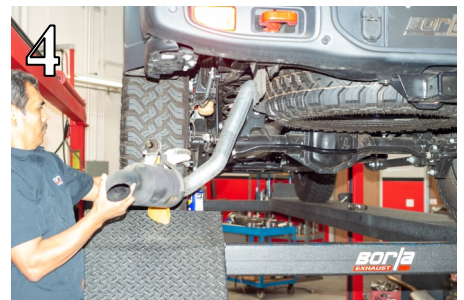
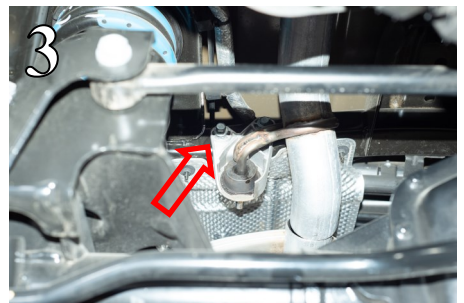
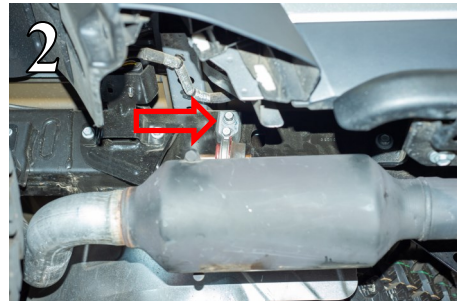

**Caution!!!** *Never work on a hot exhaust system. Serious injury in the form of burns can result if the vehicle has been in use and the exhaust system is hot, allow vehicle to cool for at least 1 hour. Always wear eye protection when working under any vehicle.*

**Note:** *It is our recommendation that you use a hoist or hydraulic lift to facilitate the installation of your new Borla Performance Exhaust System.*

**Taking all under car safety precautions, lift the vehicle using a hoist or hydraulic lift. Once this has been done, you may begin the removal of your old exhaust system from your vehicle.**

**Note:** *Before removing the original exhaust system from your vehicle, please compare the parts you have received with the bill of materials provided on the previous page to assure that you have all the parts necessary for the installation of your new Borla Performance Exhaust System.*

**Note:** *With a used vehicle, we suggest a penetrating spray lubricant to be applied liberally to all exhaust fasteners and allowing a significant period of time for the chemical to lubricate the threads before attempting to disassemble.*

## Original Exhaust System Removal

7. Loosen the nut securing the front muffler assembly clamp to the vehicle (fig. 6). Keep the hardware and clamp for later reinstallation.
8. Using a muffler stand or an additional person, carefully remove the front muffler assembly from the vehicle (fig. 7).
9. Original exhaust system removed (fig. 8).

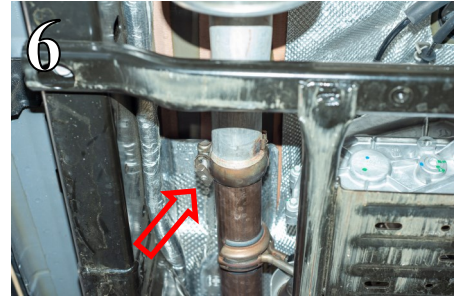

## Borla Performance Cat-Back™ Exhaust System Installation

1. Orient the components on shop floor according to the bill of materials drawing provided on page 2, 3, or 4.
2. Remove the clamp from the front of the stock exhaust system and transfer it to the front of the front muffler assembly (fig. 9). Please be aware that the front muffler assembly you received may differ in appearance depending on the part number you have.
3. Attach the front muffler assembly to the rear muffler assembly, ensuring that there is a clamp over the connecting point (fig. 10). Do not tighten the clamp yet.
4. Install the front and rear muffler assemblies together onto the vehicle (fig. 11).
5. Place the hanger from the previous step into its rubber isolator (fig. 12).
6. Reinstall the rubber isolator that came off with the stock exhaust system to secure the rear hanger of the Borla rear muffler assembly to the vehicle (fig. 13).

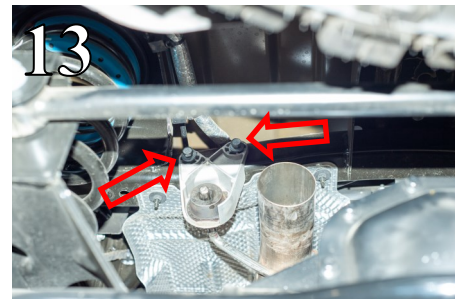
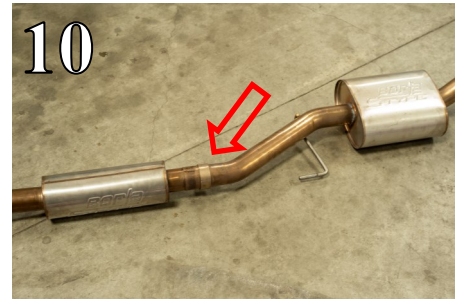
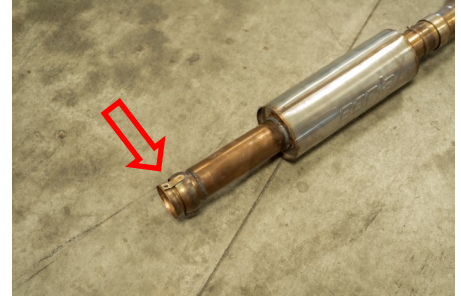

**WARNING:** Use extreme caution during installation. Torque all fasteners according to manufacturer's torque values and tightening sequence. **DO NOT** use air impact tools to tighten fasteners on Borla Performance Exhaust Systems. Use of such tools may result in bent flanges or gasket contact areas leading to exhaust leaks.

**NOTE:** When you first start your vehicle after the installation of your new Borla Performance Exhaust System, there may be some smoke and fumes coming from the system. This is a protective oil based coating used in the manufacturing of mandrel bent performance exhaust tubing. This is not a problem and will disappear within a very short period of time after the exhaust has reached normal operating temperatures.

## Borla Performance Cat-Back™ Exhaust System Installation Cont'd

7. Slide a clamp over the inlet of the Y-pipe assembly and connect it to the outlet of the rear muffler assembly (fig. 14).
8. Place a clamp over the inlet of the R/H over-axle pipe assembly and connect it to the R/H outlet of the Y-pipe assembly (fig. 15). **Note: the parts provided will be different in appearance (black coating) than those pictured in this document.**
9. Attach the provided rubber isolator to the provided hanger bracket (fig. 16).
10. Install the provided tab onto the R/H side of the rear frame rail (fig. 17).
11. Insert the R/H over-axle pipe assembly's hanger into the rubber isolator (fig. 18).

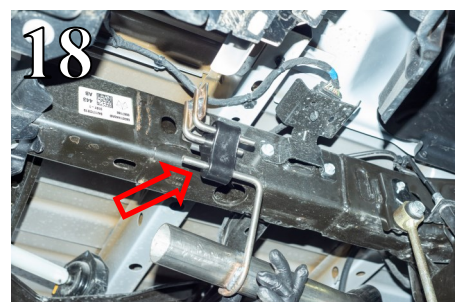
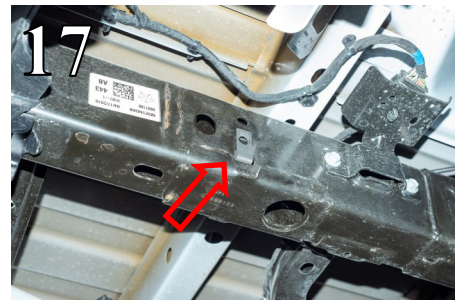
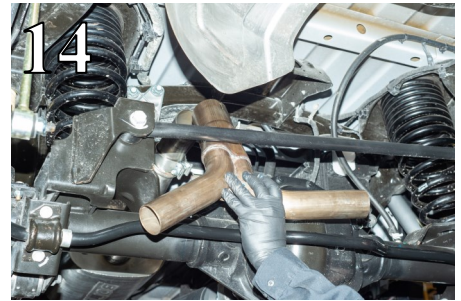

**WARNING:** Use extreme caution during installation. Torque all fasteners according to manufacturer's torque values and tightening sequence. **DO NOT** use air impact tools to tighten fasteners on Borla Performance Exhaust Systems. Use of such tools may result in bent flanges or gasket contact areas leading to exhaust leaks.

**NOTE:** When you first start your vehicle after the installation of your new Borla Performance Exhaust System, there may be some smoke and fumes coming from the system. This is a protective oil based coating used in the manufacturing of mandrel bent performance exhaust tubing. This is not a problem and will disappear within a very short period of time after the exhaust has reached normal operating temperatures.

## Borla Performance Cat-Back™ Exhaust System Installation Cont'd

12. Reinstall the stock hanger bracket onto the L/H rear frame rail (fig. 19).
13. Slide a clamp over the inlet of the L/H over-axle pipe assembly and connect it to the L/H outlet of the Y-pipe (fig. 20).
14. Insert the L/H over-axle pipe hanger into the rubber isolator (fig. 20).
15. L/H and R/H over-axle pipes installed (fig. 21).
16. Slide clamps over the inlets of the L/H and R/H tailpipe assemblies and connect them to the outlets of the over-axle pipe assemblies (fig. 22).
17. Check your exhaust system for proper clearance under the vehicle and also for tip alignment. Starting at the front flanges and moving to the rear of vehicle, tighten the flange hardware/bolts. Orient the position of bolt (on supplied clamps) between (not over) pipe notches and tighten to 35 ft. lbs. torque.
18. Align tips and tighten hardware. Loosen clamps to rotate or slide pipe for better alignment.
19. Before starting your vehicle, make sure to check all wires, hoses, brake lines, body parts and tires for safe clearance from the exhaust system.
20. Start the vehicle and check for any leaks. If any leaks are found, determine cause (such as loose or incorrectly positioned clamp) and repair as necessary.

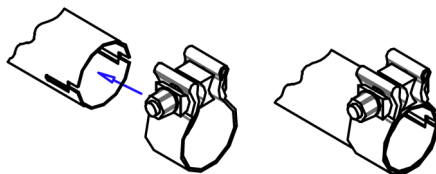
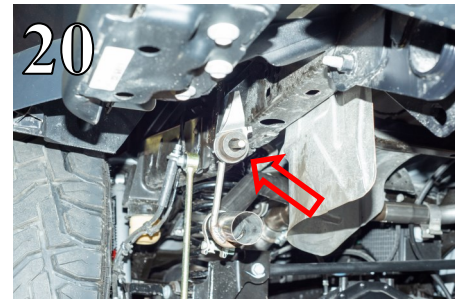
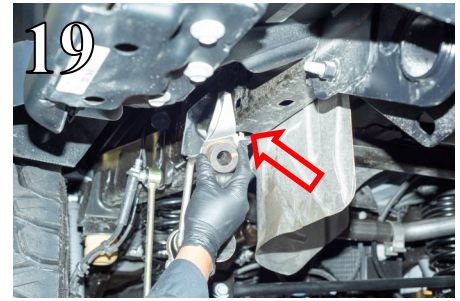

**WARNING:** Use extreme caution during installation. Torque all fasteners according to manufacturer's torque values and tightening sequence. **DO NOT** use air impact tools to tighten fasteners on Borla Performance Exhaust Systems. Use of such tools may result in bent flanges or gasket contact areas leading to exhaust leaks.

**NOTE:** When you first start your vehicle after the installation of your new Borla Performance Exhaust System, there may be some smoke and fumes coming from the system. This is a protective oil based coating used in the manufacturing of mandrel bent performance exhaust tubing. This is not a problem and will disappear within a very short period of time after the exhaust has reached normal operating temperatures.

### INSTALLATION INSTRUCTIONS

Jeep Gladiator 3.6L PNs 140814CB, 140815CB, 140816CB