

Jeep Wrangler Climber PNs 140747, 140787



******* Please compare the parts in the box with the bill of materials provided *****
(view the following pages) to assure that you have all the parts necessary for this installation.**

These instructions have been written to help you with the installation of your Borla Performance System. Please read this document completely before beginning the installation of your system.

Thank you for purchasing a Borla Performance exhaust system.

Borla Performance exhaust system PN 140747 is designed for the Jeep Wrangler Unlimited equipped with a 3.6L V6 engine, 4WD automatic or manual transmission.

Borla Performance exhaust system PN 140787 is designed for the Jeep Wrangler Unlimited equipped with a 2.0L I4 engine, 4WD automatic transmission.

Borla Performance Industries recommends that an exhaust shop or professional after market parts installer, who has all the necessary equipment, tools and experienced personnel needed for proper installation, should perform the installation of this system. However, if you decide to perform the installation, we recommend someone should help you. Ensure the installer uses all under car safety precautions including eye protection.

Please take time to read and understand the following...

By installing your Borla Performance exhaust system, you indicate that you have read this document and you agree with the terms stated below.

It is the responsibility of the purchaser to follow all installation instruction guidelines and safety procedures supplied with your Borla Performance exhaust system.

Borla Performance Industries assumes no responsibility for damages occurring from misuse, abuse, improper installation, improper operation, lack of responsible care, or all previously stated reasons resulting from incompatibility with other manufacturer's products and/or systems.

Included with your Borla Performance exhaust system is a warranty card. Please read it carefully before you begin any work on your vehicle. If you should have any questions regarding our warranty policy, installation, or any other matter pertaining to your new Borla Performance exhaust system, please give us a call at the number provided on the warranty card.

Minimum Required Tool List:

TOOLS:

1. 3/8" drive ratchet
2. 3/8" drive extension 3"
3. 15mm socket
4. 13mm socket
5. Pry bar

SHOP SUPPLIES:

1. Spray lubricant

Borla Performance - Bill of Materials

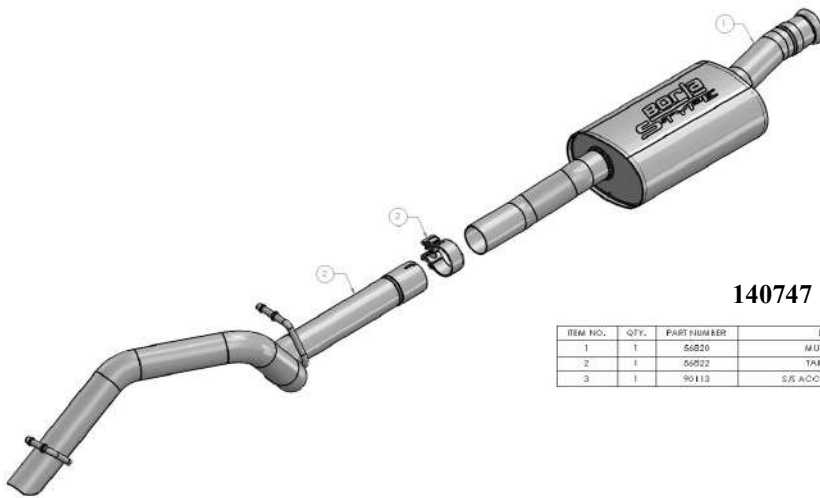

140747

ITEM NO.	QTY.	PART NUMBER	DESCRIPTION
1	1	56920	MUFFLER ASSEMBLY
2	1	56922	TAILPIPE ASSEMBLY
3	1	90113	S/S ACCESSAL CLAMP Ø2.60

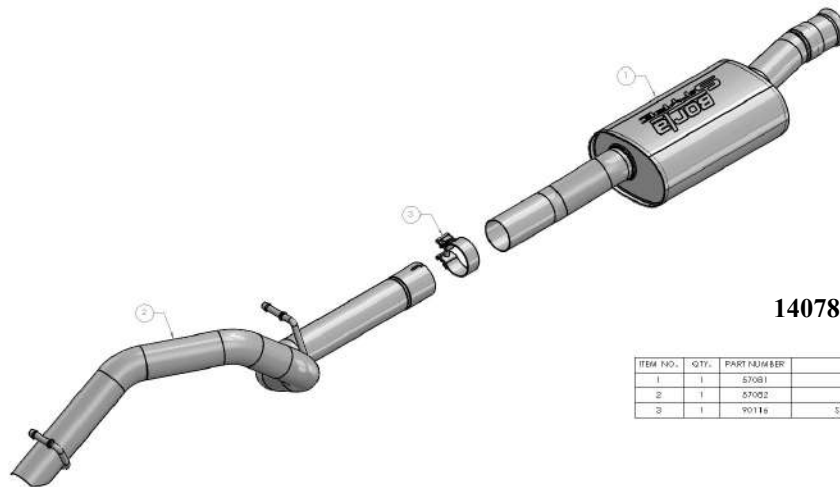

140787

ITEM NO.	QTY.	PART NUMBER	DESCRIPTION
1	1	57081	MUFFLER ASSEMBLY
2	1	57082	TAILPIPE ASSEMBLY
3	1	90116	S/S ACCESSAL CLAMP Ø2.75

Caution!!! *Never work on a hot exhaust system. Serious injury in the form of burns can result if the vehicle has been in use and the exhaust system is hot, allow vehicle to cool for at least 1 hour. Always wear eye protection when working under any vehicle.*

Note: *It is our recommendation that you use a hoist or hydraulic lift to facilitate the installation of your new Borla Performance Exhaust System.*

Taking all under car safety precautions, lift the vehicle using a hoist or hydraulic lift. Once this has been done, you may begin the removal of your old exhaust system from your vehicle.

Note: *Before removing the original exhaust system from your vehicle, please compare the parts you have received with the bill of materials provided on the previous page to assure that you have all the parts necessary for the installation of your new Borla Performance Exhaust System.*

Note: *With a used vehicle, we suggest a penetrating spray lubricant to be applied liberally to all exhaust fasteners and allowing a significant period of time for the chemical to lubricate the threads before attempting to disassemble.*

Original Exhaust System Removal

1. Loosen clamp on rear muffler pipe above the rear axle. (See Fig. 1)
2. Remove the two hangers located on the rubber brackets. (See Fig. 2)
3. Remove rear muffler assembly from vehicle. (See Figs. 3A & 3B)
4. Using a muffler stand or an additional person to support the center muffler assembly.
5. Loosen clamp on front muffler assembly. Remove (2) hangers from the rubber isolators and this assembly from vehicle. (See Fig. 4)
6. Remove mid pipe assembly from vehicle. (See Fig. 5)

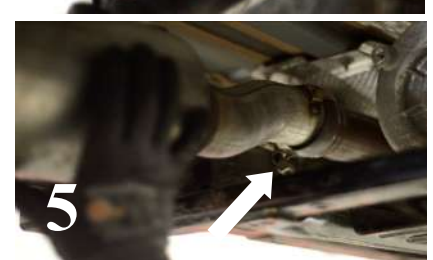
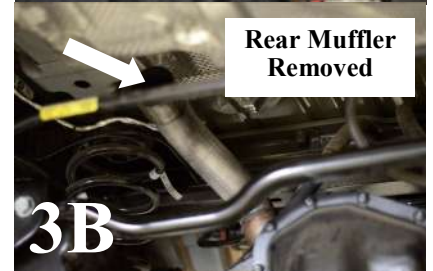
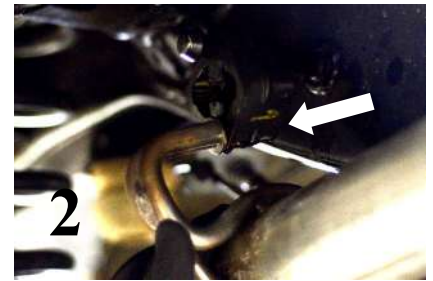

Borla Performance System Installation

1. Orient the components on the shop floor according to the page-2 drawing.
2. For 2.0L Wranglers, remove the crossmember as pictured. (See Fig. 6)
3. Place a clamp over the expanded end of **Muffler Assembly** and slip over the front pipe. (See Fig. 7) **DO NOT TIGHTEN CLAMP.**
4. Place a clamp over expanded end of **Tail-Pipe Assembly** and slip end over the **Muffler Assembly** outlet inserting hanger into rubber isolator. **DO NOT TIGHTEN CLAMPS.** (See Fig. 8)
5. Check your exhaust system for proper clearance under the vehicle. (See Fig. 9)
6. Once position has been determined to be correct, tighten the hardware (starting at the front clamp and working to the rear clamp) tightening clamp bolts to 32-35ft. lbs. (See Fig. 10)
7. **Before starting your vehicle, make sure to check all wires, hoses, brake lines, body parts and tires for safe clearance from the exhaust system.**
8. Start vehicle and check for any leaks. If any leaks are found, determine cause (such as loose or incorrectly positioned clamp) and repair as necessary.

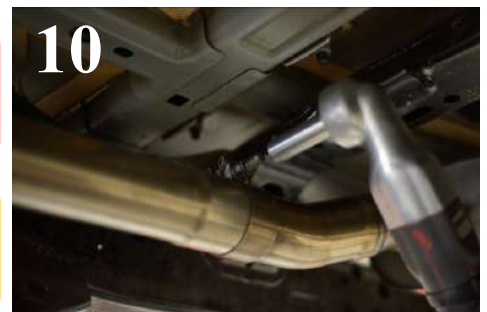

WARNING: Use extreme caution during installation. Torque all fasteners according to manufacturer's torque values and tightening sequence. **DO NOT** use air impact tools to tighten fasteners on Borla Performance Exhaust Systems. Use of such tools may result in bent flanges or gasket contact areas leading to exhaust leaks.

NOTE: When you first start your vehicle after the installation of your new Borla Performance Exhaust System, there may be some smoke and fumes coming from the system. This is a protective oil based coating used in the manufacturing of mandrel bent performance exhaust tubing. This is not a problem and will disappear within a very short period of time after the exhaust has reached normal operating temperatures.