

Honda Accord Sport 1.5L & 2.0L PN 140786



******* Please compare the parts in the box with the bill of materials provided *****
to assure that you have all the parts necessary for this installation.**

These instructions have been written to help you with the installation of your Borla Performance exhaust system. Please read this document completely before beginning the installation of your system.

Thank you for purchasing a Borla Performance Cat-Back™ exhaust system.

This Borla Performance Cat-Back™ exhaust system (PN 140786) is designed for the Honda Accord, equipped with a 1.5L or 2.0L I4 turbocharged engine and FWD automatic or manual transmission.

Borla Performance Industries recommends that an exhaust shop or professional after market parts installer, who has all the necessary equipment, tools and experienced personnel needed for proper installation, should perform the installation of this system. However, if you decide to perform the installation, we recommend someone should help you. Ensure the installer uses all under car safety precautions including eye protection.

Please take time to read and understand the following...

By installing your Borla Performance exhaust system, you indicate that you have read this document and you agree with the terms stated below.

It is the responsibility of the purchaser to follow all installation instruction guidelines and safety procedures supplied with your Borla Performance Exhaust System.

Borla Performance Industries assumes no responsibility for damages occurring from misuse, abuse, improper installation, improper operation, lack of responsible care, or all previously stated reasons resulting from incompatibility with other manufacturer's products and/or systems.

Included with your Borla Performance exhaust system is a warranty card. Please read it carefully before you begin any work on your vehicle. If you should have any questions regarding our warranty policy, installation, or any other matter pertaining to your new Borla Performance exhaust system, please give us a call at the number provided on the warranty card.

Minimum Required Tool List:

TOOLS:

1. 3/8" drive ratchet
2. 3/8" drive extension 6"
3. 15mm deep well socket
4. 14mm socket
5. 12mm socket
6. Pry bar

SHOP SUPPLIES:

1. Spray lubricant

Borla Performance - Bill of Materials

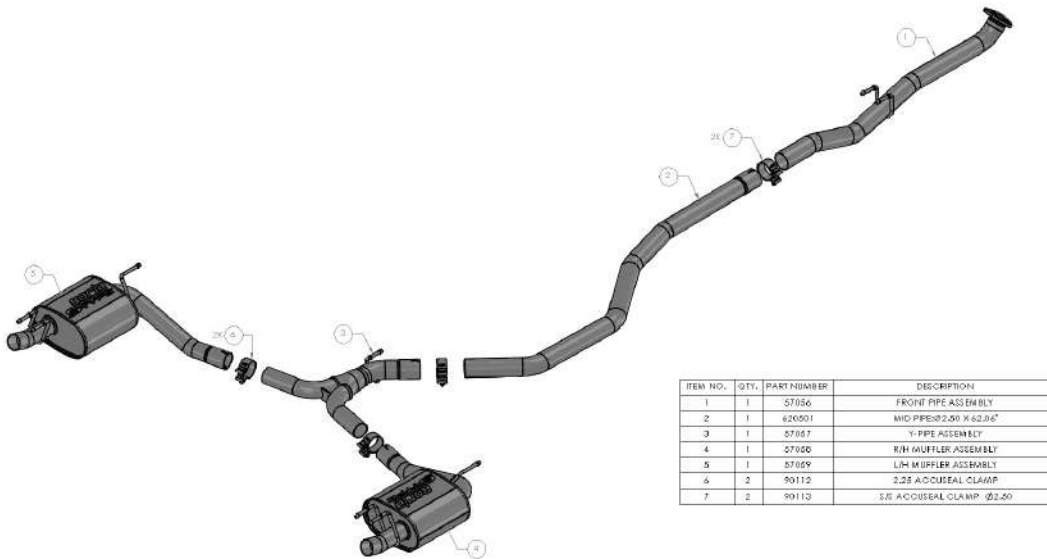

ITEM NO.	QTY.	PART NUMBER	DESCRIPTION
1	1	57056	FRONT PIPE ASSEMBLY
2	1	62001	MID-PPE#2.50 X 62.06"
3	1	57007	Y-PIPE ASSEMBLY
4	1	57006	R/H MUFFLER ASSEMBLY
5	1	57009	L/H MUFFLER ASSEMBLY
6	2	90112	2.25 ACOUSEAL CLAMP
7	2	90113	S/S ACOUSEAL CLAMP Ø2.50

Caution!!! *Never work on a hot exhaust system. Serious injury in the form of burns can result if the vehicle has been in use and the exhaust system is hot, allow vehicle to cool for at least 1 hour. Always wear eye protection when working under any vehicle.*

Note: It is our recommendation that you use a hoist or hydraulic lift to facilitate the installation of your new Borla Performance Exhaust System.

Taking all under car safety precautions, lift the vehicle using a hoist or hydraulic lift. Once this has been done, you may begin the removal of your old exhaust system from your vehicle.

Note: Before removing the original exhaust system from your vehicle, please compare the parts you have received with the bill of materials provided on the previous page to assure that you have all the parts necessary for the installation of your new Borla Performance Exhaust System.

Note: With a used vehicle, we suggest a penetrating spray lubricant to be applied liberally to all exhaust fasteners and allowing a significant period of time for the chemical to lubricate the threads before attempting to disassemble.

Original Exhaust System Removal

1. Lubricate all hangers, rubber isolators, bolts and nuts.
2. Remove the mounting bolt from the L/H rearmost tailpipe hanger (fig. 1). Keep hardware for later reinstallation.
3. Remove hanger from rubber isolator near front resonator (fig. 2).
4. Remove the crossmember and keep hardware for later reinstallation (fig. 4).
5. Remove hangers from rubber isolators near rear muffler assembly (fig. 5). Please note that not all hangers are pictured in this document.
6. Use a flat screwdriver to remove the original ring gasket from the stock system.

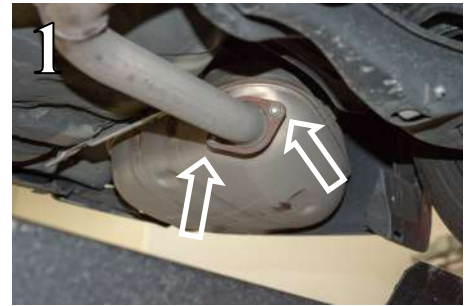

Caution!!! *Never work on a hot exhaust system. Serious injury in the form of burns can result if the vehicle has been in use and the exhaust system is hot, allow vehicle to cool for at least 1 hour. Always wear eye protection when working under any vehicle.*

Note: *It is our recommendation that you use a hoist or hydraulic lift to facilitate the installation of your new Borla Performance Exhaust System.*

Taking all under car safety precautions, lift the vehicle using a hoist or hydraulic lift. Once this has been done, you may begin the removal of your old exhaust system from your vehicle.

Note: *Before removing the original exhaust system from your vehicle, please compare the parts you have received with the bill of materials provided on the previous page to assure that you have all the parts necessary for the installation of your new Borla Performance Exhaust System.*

Note: *With a used vehicle, we suggest a penetrating spray lubricant to be applied liberally to all exhaust fasteners and allowing a significant period of time for the chemical to lubricate the threads before attempting to disassemble.*

Original Exhaust System Removal Cont'd

7. Remove hanger from rubber isolator near front resonator (fig. 6). You may need to remove this isolator with the stock exhaust and then transfer it to the Borla system.
8. Carefully remove exhaust from the vehicle (fig. 7).
9. Original exhaust system removed.
10. Note: you may need to loosen the fasteners on the lower engine cover to access the front pipe flange (fig. 8).

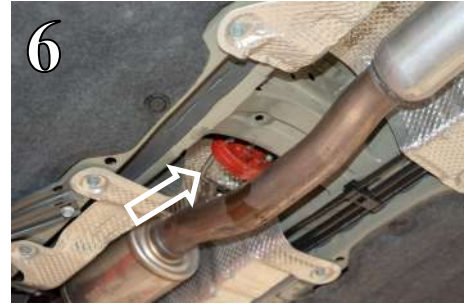

Borla Performance Cat-Back™ Exhaust System Installation

1. Orient components on shop floor according to page-2 drawing.
2. Install original ring gasket onto Borla front flange assembly.
3. Install the stock front pipe rubber isolator onto the Borla **front pipe assembly** (fig. 9).
4. Install the **front pipe assembly** flange to the outlet of the stock downpipe using the original hardware (fig. 10).
5. Tighten the hardware on the **front pipe assembly** (fig. 11).
6. Re-install the **crossmember** using the original hardware (fig. 12).
7. Place a clamp on the **mid pipe** and slide the inlet over the outlet of the front pipe assembly.

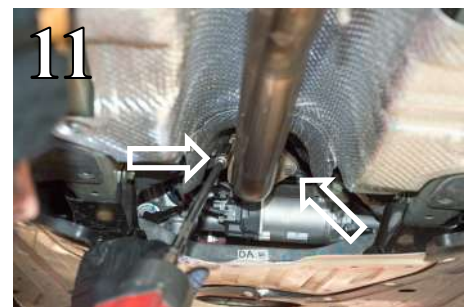
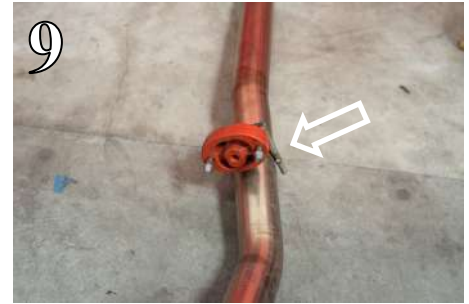

WARNING: Use extreme caution during installation. Torque all fasteners according to manufacturer's torque values and tightening sequence. **DO NOT** use air impact tools to tighten fasteners on Borla Performance Exhaust Systems. Use of such tools may result in bent flanges or gasket contact areas leading to exhaust leaks.

NOTE: When you first start your vehicle after the installation of your new Borla Performance Exhaust System, there may be some smoke and fumes coming from the system. This is a protective oil based coating used in the manufacturing of mandrel bent performance exhaust tubing. This is not a problem and will disappear within a very short period of time after the exhaust has reached normal operating temperatures.

Borla Performance Cat-Back™ Exhaust System Installation Cont'd

1. Place a clamp on the **y-pipe assembly** and slide the inlet over the outlet of the mid pipe (fig. 14).
2. Insert **rear muffler assembly hangers** into rubber isolators if they were removed with the stock exhaust (fig. 11). Please note that not all hangers are pictured in this document.
3. Slide a clamp over the inlet of the **rear muffler assembly** and place it over the outlet of the y-pipe assembly.
4. Insert **rear muffler assembly outlet** into bumper valance exit (fig. 17).
5. Check your exhaust system for proper clearance under the vehicle and also for tip alignment. Starting at front flanges and moving to rear of vehicle, tighten flange hardware bolts. Orient position of bolt (on supplied clamps) between (not over) pipe notches and tighten to 35 ft. lbs. torque.
6. Align tips and tighten hardware. Loosen clamps to rotate or slide pipe for better alignment.
7. Before starting your vehicle, make sure to check all wires, hoses, brake lines, body parts and tires for safe clearance from the exhaust system.
8. Start vehicle and check for any leaks. If any leaks are found, determine cause (such as loose or incorrectly positioned clamp) and repair as necessary.



WARNING: Use extreme caution during installation. Torque all fasteners according to manufacturer's torque values and tightening sequence. **DO NOT** use air impact tools to tighten fasteners on Borla Performance Exhaust Systems. Use of such tools may result in bent flanges or gasket contact areas leading to exhaust leaks.

NOTE: When you first start your vehicle after the installation of your new Borla Performance Exhaust System, there may be some smoke and fumes coming from the system. This is a protective oil based coating used in the manufacturing of mandrel bent performance exhaust tubing. This is not a problem and will disappear within a very short period of time after the exhaust has reached normal operating temperatures.