

Exhaust System Installation for the Toyota 4Runner PNs 140379, 140760



******* Please compare the parts in the box with the bill of materials provided *****
(view the following pages) to assure that you have all the parts necessary for this installation.**

These instructions have been written to help you with the installation of your Borla Performance System. Please read this document completely before beginning the installation of your system.

Thank you for purchasing a Borla Performance Cat-Back™ exhaust system.

Borla Performance Cat-Back™ exhaust system PNs 140379 and 140760 are designed for the Toyota 4Runner equipped with a 4.0L engine 2WD or 4WD and automatic or manual transmissions.

Borla Performance Industries recommends that an exhaust shop or professional after market parts installer perform the installation of this system. However, if you decide to perform the installation on your own it is recommended that two people are used. This installation should not be performed by one person due to the risk of injury. Ensure the installers use all under car safety precautions including eye protection.

Please take time to read and understand the following...

By installing your Borla Performance exhaust system, you indicate that you have read this document and you agree with the terms stated below. It is the responsibility of the purchaser to follow all installation instruction guidelines and safety procedures supplied with your Borla Performance exhaust system.

Borla Performance Industries assumes no responsibility for damages occurring from misuse, abuse, improper installation, improper operation, lack of responsible care, or all previously stated reasons resulting from incompatibility with other manufacturer's products and/or systems.

Included with your Borla Performance exhaust system is a warranty card. Please read it carefully before you begin any work on your vehicle. If you should have any questions regarding our warranty policy, installation, or any other matter pertaining to your new Borla Performance Exhaust System, please give us a call at the number provided on the warranty card.

Minimum Required Tool List:

TOOLS:

1. 3/8” drive ratchet
2. 3/8” drive extension 3”
3. 15mm socket
4. Pry bar

SHOP SUPPLIES:

1. Spray lubricant

Borla Performance Cat-back™ - Bill of Materials

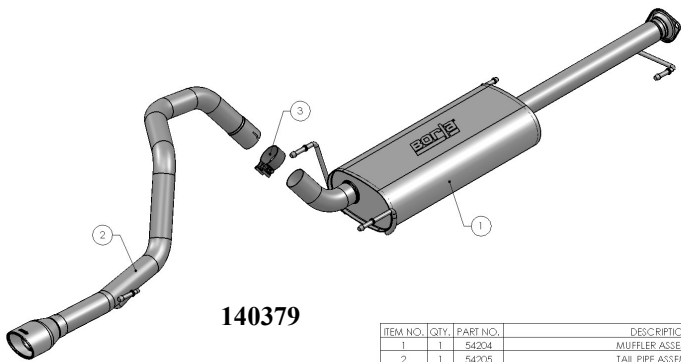

140379

ITEM NO.	QTY.	PART NO.	DESCRIPTION
1	1	54204	MUFFLER ASSEMBLY
2	1	54205	TAIL PIPE ASSEMBLY
3	1	90113	S/S ACCUSEAL CLAMP Ø2.50

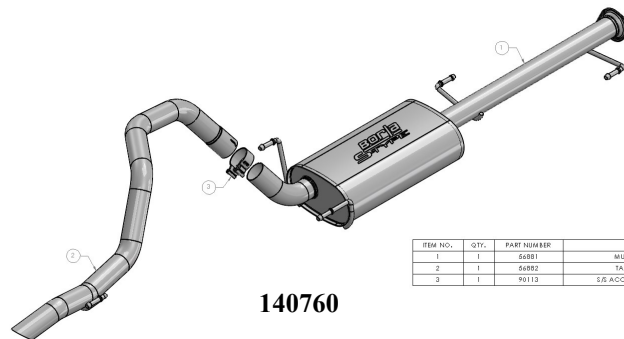

140760

ITEM NO.	QTY.	PART NUMBER	DESCRIPTION
1	1	64881	MUFFLER ASSEMBLY
2	1	64882	TAILPIPE ASSEMBLY
3	1	90113	S/S ACCUSEAL CLAMP Ø2.50

Caution!!! Never work on a hot exhaust system. Serious injury in the form of burns can result if the vehicle has been in use and the exhaust system is hot, allow vehicle to cool for at least 1 hour. Always wear eye protection when working under any vehicle.

Note: It is our recommendation that you use a hoist or hydraulic lift to facilitate the installation of your new Borla Performance Exhaust System.

Taking all under car safety precautions, lift the vehicle using a hoist or hydraulic lift. Once this has been done, you may begin the removal of your old exhaust system from your vehicle.

Note: Before removing the original exhaust system from your vehicle, please compare the parts you have received with the bill of materials provided on the previous page to assure that you have all the parts necessary for the installation of your new Borla Performance Exhaust System.

Note: With a used vehicle, we suggest a penetrating spray lubricant to be applied liberally to all exhaust fasteners and allowing a significant period of time for the chemical to lubricate the threads before attempting to disassemble.

Original Exhaust System Removal

1. Lubricate all hangers and rubber isolators. Unbolt two (2) bolts on front flange behind the rear axle (fig. 1). Remove the rear tail-pipe section from hangers and remove tailpipe (fig. 2).
2. Use a muffler stand or an additional person to hold the center muffler into position. Remove (2) bolts from flange in front of the muffler (fig. 3). Remove the hangers from the rubber isolators and carefully remove center exhaust from the vehicle.

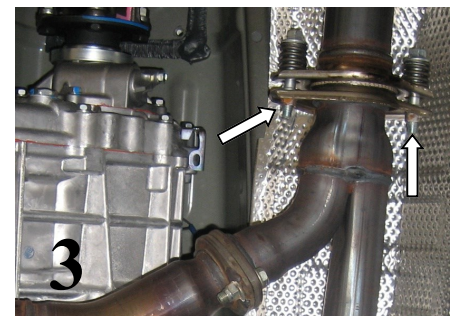
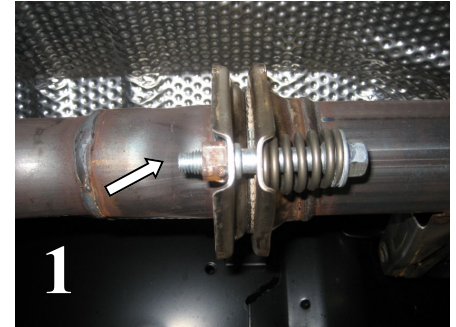

WARNING: Use extreme caution during installation. Torque all fasteners according to manufacturer's torque values and tightening sequence. **DO NOT** use air impact tools to tighten fasteners on Borla Performance Exhaust Systems. Use of such tools may result in bent flanges or gasket contact areas leading to exhaust leaks.

NOTE: When you first start your vehicle after the installation of your new Borla Performance Exhaust System, there may be some smoke and fumes coming from the system. This is a protective oil based coating used in the manufacturing of mandrel bent performance exhaust tubing. This is not a problem and will disappear within a very short period of time after the exhaust has reached normal operating temperatures.

Borla Performance Cat-Back™ Exhaust System Installation

1. Install the Muffler Assembly into rubber isolators. Using original hardware, attached Muffler Assembly to front flange keeping bolt hardware loose (figs. 4 & 5).
2. Slide the supplied Clamp over the notched-end of the Tail-Pipe Assembly and install Tail-Pipe Assembly over rear axle and into front Muffler Assembly pipe. Install hangars into the rubber isolators.
3. Check your exhaust system for proper clearance under the vehicle and also for tip alignment (fig. 7). Note: 140760 will differ in appearance to system in image.
4. Once position has been determined to be correct, tighten the flange hardware to 18-22 ft. lbs. (fig. 6).
5. Verify clamp bolt is rotated between tubing notches (see image on right). Tighten clamp bolt 33-35 ft. lb.
6. Before starting your vehicle, make sure to check all wires, hoses, brake lines, body parts and tires for safe clearance from the exhaust system.
7. Start vehicle and check for any leaks. If any leaks are found, determine cause and repair as necessary.

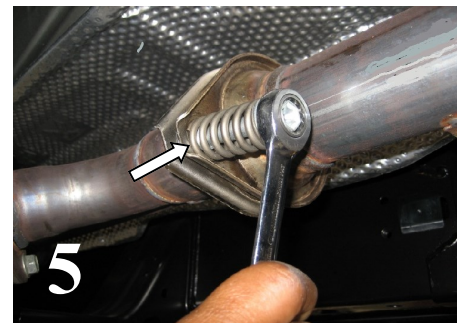
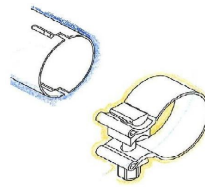

WARNING: Use extreme caution during installation. Torque all fasteners according to manufacturer's torque values and tightening sequence. **DO NOT** use air impact tools to tighten fasteners on Borla Performance Exhaust Systems. Use of such tools may result in bent flanges or gasket contact areas leading to exhaust leaks.

NOTE: When you first start your vehicle after the installation of your new Borla Performance Exhaust System, there may be some smoke and fumes coming from the system. This is a protective oil based coating used in the manufacturing of mandrel bent performance exhaust tubing. This is not a problem and will disappear within a very short period of time after the exhaust has reached normal operating temperatures.