

## Installation for Jeep Grand Cherokee Trackhawk PNs 140755, 140756, 60672BC, 60673CF, 60674, and 60675



**\*\*\*\*\* Please compare the parts in the box with the bill of materials provided \*\*\*\*\*  
to assure that you have all the parts necessary for this installation.**

These instructions have been written to help you with the installation of your Borla Performance exhaust system. Please read this document completely before beginning the installation of your system.

Thank you for purchasing a Borla Performance exhaust system.

Borla Performance Cat-Back™ exhaust systems (PNs 140755 and 140756) are designed for the Jeep Grand Cherokee Trackhawk equipped with a 6.2L supercharged V8 engine, automatic transmission.

Borla Performance optional tip assemblies (PNs 60672BC and 60673CF) are designed to replace OE tip assemblies when paired with Borla Cat-Back™ exhaust systems 140755 & 140756 *only*. (Not for use with OE trailer hitch installed on vehicle.)

Borla Performance front muffler sections (PNs 60674 and 60675) are designed to replace front mufflers of Borla Cat-Back™ exhaust systems 140755 & 140756 *only*.

Borla Performance Industries recommends that an exhaust shop or professional after market parts installer, who has all the necessary equipment, tools and experienced personnel needed for proper installation, should perform the installation of this system. However, if you decide to perform the installation, we recommend someone should help you. Ensure the installer uses all under car safety precautions including eye protection.

*Please take time to read and understand the following...*

By installing your Borla Performance exhaust system, you indicate that you have read this document and you agree with the terms stated below.

It is the responsibility of the purchaser to follow all installation instruction guidelines and safety procedures supplied with your Borla Performance exhaust system.

Borla Performance Industries assumes no responsibility for damages occurring from misuse, abuse, improper installation, improper operation, lack of responsible care, or all previously stated reasons resulting from incompatibility with other manufacturer's products and/or systems.

Included with your Borla Performance exhaust system is a warranty card. Please read it carefully before you begin any work on your vehicle. If you should have any questions regarding our warranty policy, installation, or any other matter pertaining to your new Borla Performance Exhaust System, please give us a call at the number provided on the warranty card.

**Minimum Required Tool List:**

**TOOLS:**

1. 3/8" drive ratchet
2. 3/8" drive extension 6"
3. 15mm socket
4. 13mm socket
5. 15mm wrench
6. Pry bar

**SHOP SUPPLIES:**

1. Spray Lubricant

**Borla Performance - Bill of Materials**

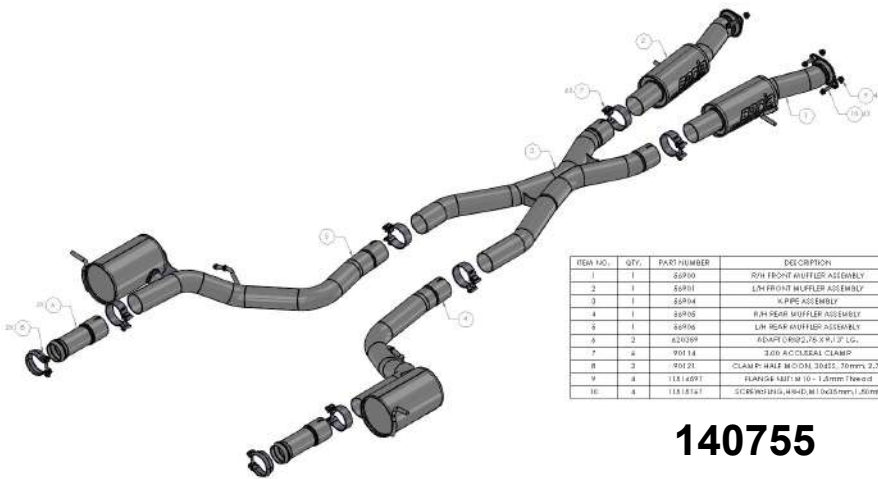

| ITEM NO. | QTY. | PART NUMBER | DESCRIPTION                                 |
|----------|------|-------------|---|
| 1        | 1    | 66900       | R/R FRONT MUFFLER ASSEMBLY                  |
| 2        | 1    | 66901       | L/R FRONT MUFFLER ASSEMBLY                  |
| 3        | 1    | 66904       | K-PIPE ASSEMBLY                             |
| 4        | 1    | 66905       | R/R REAR MUFFLER ASSEMBLY                   |
| 5        | 1    | 66906       | L/R REAR MUFFLER ASSEMBLY                   |
| 6        | 2    | 820269      | ADAPT ORING 2.75 X 9.12" LG.                |
| 7        | 4    | 90114       | 3.00" ACCESSORY CLAMP                       |
| 8        | 3    | 90121       | CLAMP HALF MODL 20433, 70MM X 2.75"         |
| 9        | 4    | 11814991    | FLANGE NUT/SAE - 1.875" Thread              |
| 10       | 4    | 11815767    | SCREW/FLG, 1/8" DIA, 8.11 X 0.25mm, 1.20cmP |

**140755**

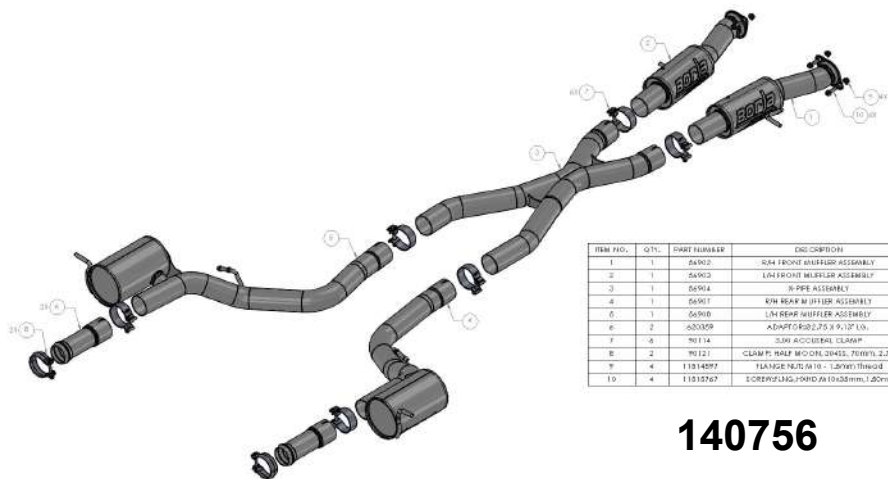

| ITEM NO. | QTY. | PART NUMBER | DESCRIPTION                                 |
|----------|------|-------------|---|
| 1        | 1    | 66902       | R/R FRONT MUFFLER ASSEMBLY                  |
| 2        | 1    | 66903       | L/R FRONT MUFFLER ASSEMBLY                  |
| 3        | 1    | 66904       | K-PIPE ASSEMBLY                             |
| 4        | 1    | 66907       | R/R REAR MUFFLER ASSEMBLY                   |
| 5        | 1    | 66908       | L/R REAR MUFFLER ASSEMBLY                   |
| 6        | 2    | 820269      | ADAPT ORING 2.75 X 9.12" LG.                |
| 7        | 4    | 90114       | 3.00" ACCESSORY CLAMP                       |
| 8        | 2    | 90121       | CLAMP HALF MODL 20433, 70MM X 2.75"         |
| 9        | 4    | 11814997    | FLANGE NUT/SAE - 1.875" Thread              |
| 10       | 4    | 11815767    | SCREW/FLG, 1/8" DIA, 8.11 X 0.25mm, 1.20cmP |

**140756**



**60672BC**

| ITEM NO. | QTY. | PART NUMBER | DESCRIPTION      |
|----------|------|-------------|------------------|
| 1        | 1    | 56909BC     | R/H TIP ASSEMBLY |
| 2        | 1    | 56910BC     | L/H TIP ASSEMBLY |

Borla Performance tip assemblies (PNs 60672BC, 60673CF) are designed to fit Borla Cat-Back™ exhaust systems 140756 & 140756 only and are not compatible with the stock exhaust system.

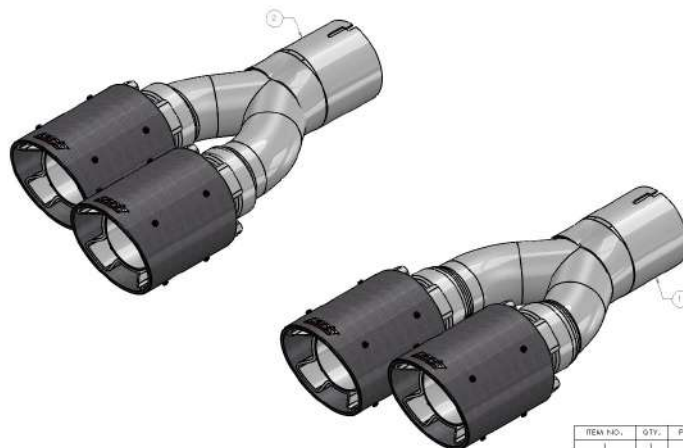

**60673CF**

| ITEM NO. | QTY. | PART NUMBER | DESCRIPTION      |
|----------|------|-------------|------------------|
| 1        | 1    | 56911CF     | R/H TIP ASSEMBLY |
| 2        | 1    | 56912CF     | L/H TIP ASSEMBLY |

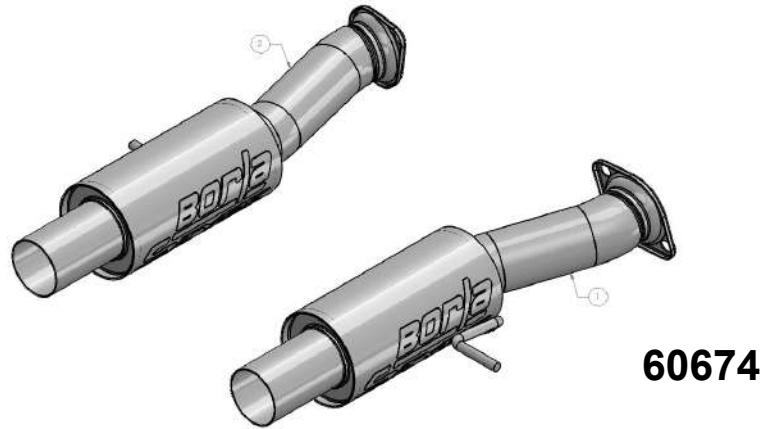

**60674**

| ITEM NO. | QTY. | PART NUMBER | DESCRIPTION                |
|----------|------|-------------|----------------------------|
| 1        | 1    | 56900       | R/H FRONT MUFFLER ASSEMBLY |
| 2        | 1    | 56901       | L/H FRONT MUFFLER ASSEMBLY |

**Borla Performance front muffler sections (PNs 60674, 60675) are designed to replace front mufflers of Borla Cat-Back™ exhaust systems 140756 & 140756 only.**

*For ease of installation please remove R/H and L/H front mufflers and the X-pipe assembly from the vehicle. (Refer to page 6 of this manual.)*

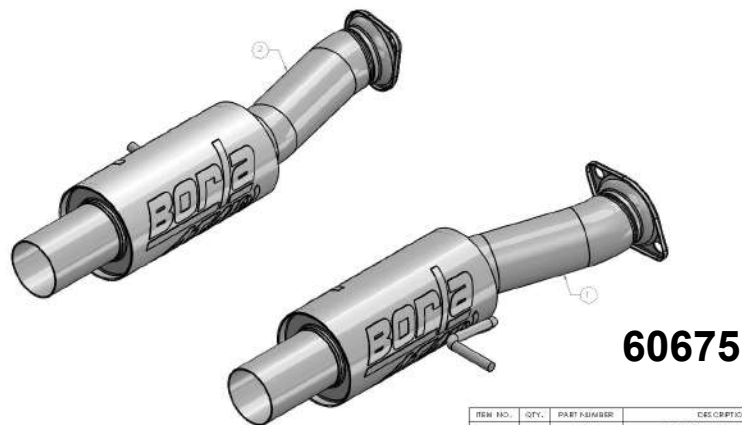

**60675**

| ITEM NO. | QTY. | PART NUMBER | DESCRIPTION                |
|----------|------|-------------|----------------------------|
| 1        | 1    | 56902       | R/H FRONT MUFFLER ASSEMBLY |
| 2        | 1    | 56903       | L/H FRONT MUFFLER ASSEMBLY |

**Caution!!!** *Never work on a hot exhaust system. Serious injury in the form of burns can result if the vehicle has been in use and the exhaust system is hot, allow vehicle to cool for at least 1 hour. Always wear eye protection when working under any vehicle.*

**Note:** *It is our recommendation that you use a hoist or hydraulic lift to facilitate the installation of your new Borla Performance Exhaust System.*

**Taking all under car safety precautions, lift the vehicle using a hoist or hydraulic lift. Once this has been done, you may begin the removal of your old exhaust system from your vehicle.**

**Note:** *Before removing the original exhaust system from your vehicle, please compare the parts you have received with the bill of materials provided on the previous page to assure that you have all the parts necessary for the installation of your new Borla Performance Exhaust System.*

**Note:** *With a used vehicle, we suggest a penetrating spray lubricant to be applied liberally to all exhaust fasteners and allowing a significant period of time for the chemical to lubricate the threads before attempting to disassemble.*

## Original Exhaust System Removal

1. Lubricate all hangers, rubber isolators, bolts and nuts.
2. Loosen clamp on L/H rear muffler assembly (fig. 1) and remove from vehicle.
3. Remove fasteners on L/H and R/H front muffler assembly flanges (fig. 2).
4. Remove fasteners on L/H and R/H front muffler assembly rubber isolator brackets (fig. 3). Keep hardware for later reinstallation.
5. Remove grounding strap (fig. 4) from L/H and R/H muffler assemblies. Place strap out of the way of Borla Performance exhaust system installation on vehicle.
6. Remove all original exhaust system hangers from rubber isolators. Using a muffler stand or an additional person, remove original exhaust system from vehicle (fig. 5).
7. Original exhaust system removed.

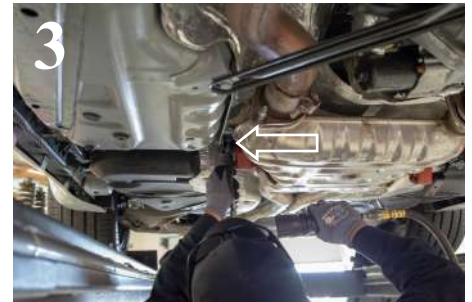



## Borla Performance Cat-Back™ Exhaust System Installation

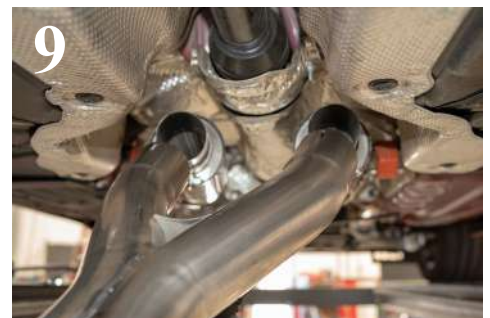

1. Orient components on floor referencing the page-2 drawing.
2. Install **L/H and R/H front muffler assemblies**, carefully inserting the hangers into the OE rubber isolators (fig. 6).
3. Hand-tight the four (4) flange bolt assemblies of the **L/H and R/H front muffler assemblies** with the provided hardware (fig. 7). Do not tighten the clamps. *The springs from the stock front muffler assembly are not required here.*
4. Place a clamp over each outlet of the **front muffler assemblies** (fig. 8). Do not tighten the clamps.
5. Insert the expanded ends of the **X-pipe assembly** into outlets of **front muffler assemblies** (fig. 8).
6. Slide the clamps over the expanded ends of the **X-pipe assembly**. Do not tighten the clamps (fig. 9).
7. Place a clamp over the expanded ends of the **L/H and R/H rear muffler assemblies** and insert into the outlets of the installed **X-pipe assembly**. Do not tighten the clamps.
8. Carefully insert hangers of **L/H and R/H rear muffler assemblies** into OE rubber isolators.
9. NOTE: it may be necessary to reverse the L/H and/or R/H OE rubber isolators for ease of installation (fig. 11). If necessary, install the L/H and/or R/H OE rubber isolators on the **L/H and R/H rear muffler assemblies** before installation.

**WARNING:** Use extreme caution during installation. Torque all fasteners according to manufacturer's torque values and tightening sequence. **DO NOT** use air impact tools to tighten fasteners on Borla Performance Exhaust Systems. Use of such tools may result in bent flanges or gasket contact areas leading to exhaust leaks.

**NOTE:** When you first start your vehicle after the installation of your new Borla Performance Exhaust System, there may be some smoke and fumes coming from the system. This is a protective oil based coating used in the manufacturing of mandrel bent performance exhaust tubing. This is not a problem and will disappear within a very short period of time after the exhaust has reached normal operating temperatures.

## Borla Performance Cat-Back™ Exhaust System Installation Cont'd

10. Remove OE clamp from OE tip assembly (fig. 12).
11. Connect OE tip assembly to Borla tailpipe (fig. 13).
12. With the components off of the vehicle, install the OE tip assembly to the **Borla tailpipe assembly**. **60672BC and 60673CF excluded**.
13. **60672BC and 60673CF only:** make a cut one (1) inch from lateral edge of belly pan as shown in fig. 15.
14. **60672BC and 60673CF only:** insert expanded ends of Borla **tip assembly** into outlets of **L/H and R/H rear muffler assemblies**. Note: do not use tailpipe adaptors (PN 620359 from page-2 drawing) with Borla tip assembly PNs 60672BC and 60673CF.
15. Check your exhaust system for proper clearance under the vehicle and also for tip alignment. Starting at front flanges and moving to rear of vehicle, tighten flange hardware bolts. Orient position of bolt (on supplied clamps) between (not over) pipe notches and tighten to 35 ft. lbs. torque.
16. Align tips and tighten hardware. Loosen clamps to rotate or slide pipe for better alignment (fig.14).
17. Before starting your vehicle, make sure to check all wires, hoses, brake lines, body parts and tires for safe clearance from the exhaust system.
18. Start vehicle and check for any leaks. If any leaks are found, determine cause (such as loose or incorrectly positioned clamp) and repair as necessary.



**WARNING:** Use extreme caution during installation. Torque all fasteners according to manufacturer's torque values and tightening sequence. **DO NOT** use air impact tools to tighten fasteners on Borla Performance Exhaust Systems. Use of such tools may result in bent flanges or gasket contact areas leading to exhaust leaks.

**NOTE:** When you first start your vehicle after the installation of your new Borla Performance Exhaust System, there may be some smoke and fumes coming from the system. This is a protective oil based coating used in the manufacturing of mandrel bent performance exhaust tubing. This is not a problem and will disappear within a very short period of time after the exhaust has reached normal operating temperatures.



## Borla Performance Front Muffler Section (60674 & 60675) System Installation



- A. Orient components on floor referencing the page-2 drawing.
- B. Loosen four (4) clamps of the **X-pipe assembly**. Slide the clamp away from the pipe notches, and use a rubber mallet to tap and loosen the pipes. Slide the **X-pipe assembly** rearwards, removing the inlet from the (installed) **front muffler assemblies** (fig. A).
- C. Loosen and remove the bolts on the flanges of each **front muffler assembly**. Remove hangers from rubber isolators and remove both **front muffler assemblies** from vehicle (fig. B).
- D. **Install (60674 or 60675) L/H and R/H front muffler assemblies**, carefully inserting the hangers into the OE rubber isolators. Hand tighten the (4) flange bolts assemblies with provided hardware.
- E. Insert inlets of the **X-Pipe assembly** into outlets of installed **front muffler assemblies**. Slide and return the clamps over each expanded end of the **X-pipe assembly**. Do not tighten the clamps.
- F. Check your exhaust system for proper clearance under the vehicle and also for tip alignment. Starting at front flanges and moving to rear of vehicle, tighten flange hardware bolts. Orient position of bolt (on supplied clamps) between (not over) pipe notches and tighten to 35 ft. lbs. torque. (See Fig. C)
- G. Before starting your vehicle, make sure to check all wires, hoses, brake lines, body parts and tires for safe clearance from the exhaust system.
- H. Start vehicle and check for any leaks. If any leaks are found, determine cause (such as loose or incorrectly positioned clamp) and repair as necessary.

**WARNING:** Use extreme caution during installation. Torque all fasteners according to manufacturer's torque values and tightening sequence. **DO NOT** use air impact tools to tighten fasteners on Borla Performance Exhaust Systems. Use of such tools may result in bent flanges or gasket contact areas leading to exhaust leaks.

**NOTE:** When you first start your vehicle after the installation of your new Borla Performance Exhaust System, there may be some smoke and fumes coming from the system. This is a protective oil based coating used in the manufacturing of mandrel bent performance exhaust tubing. This is not a problem and will disappear within a very short period of time after the exhaust has reached normal operating temperatures.