

## Exhaust System Installation for Audi S4, S5 & S5 Sportback PNs 140740, 140749



**\*\*\*\*\* Please compare the parts in the box with the bill of materials provided \*\*\*\*\*  
to assure that you have all the parts necessary for this installation.**

These instructions have been written to help you with the installation of your Borla Performance Exhaust System. Please read this document completely before beginning the installation of your system.

**Thank you for purchasing a Borla Performance Cat-Back™ Exhaust System.**

**Borla Performance Cat-Back™ Exhaust System (PN 140740) is designed for the Audi S4 or S5 equipped with a 3.0T V6 engine, automatic transmission.**

**Borla Performance Cat-Back™ Exhaust System (PN 140749) is designed for the Audi S5 Sportback equipped with a 3.0T V6 engine, automatic transmission.**

Borla Performance Industries recommends that an exhaust shop or professional after market parts installer, who has all the necessary equipment, tools and experienced personnel needed for proper installation, should perform the installation of this system. However, if you decide to perform the installation, we recommend someone should help you. Ensure the installer uses all under car safety precautions including eye protection.

*Please take time to read and understand the following...*

By installing your Borla Performance Exhaust System, you indicate that you have read this document and you agree with the terms stated below.

It is the responsibility of the purchaser to follow all installation instruction guidelines and safety procedures supplied with your Borla Performance Exhaust System.

Borla Performance Industries assumes no responsibility for damages occurring from misuse, abuse, improper installation, improper operation, lack of responsible care, or all previously stated reasons resulting from incompatibility with other manufacturer's products and/or systems.

Included with your Borla Performance Exhaust System is a warranty card. Please read it carefully before you begin any work on your vehicle. If you should have any questions regarding our warranty policy, installation, or any other matter pertaining to your new Borla Performance Exhaust System, please give us a call at the number provided on the warranty card.

**Minimum Required Tool List:**

**TOOLS:**

1. 3/8" Drive Ratchet
2. 3/8" Drive Extension 3" & 6"
3. 15mm Deep Well Socket
4. 13mm Deep Well Socket
5. 8mm Deep Well Socket
6. Flat Screwdriver
7. T-50 Torx Bit
8. T-25 Torx Bit
9. Pry Bar

**SHOP SUPPLIES:**

- 1 Spray Lubricant

**Borla Performance - Bill of Materials**

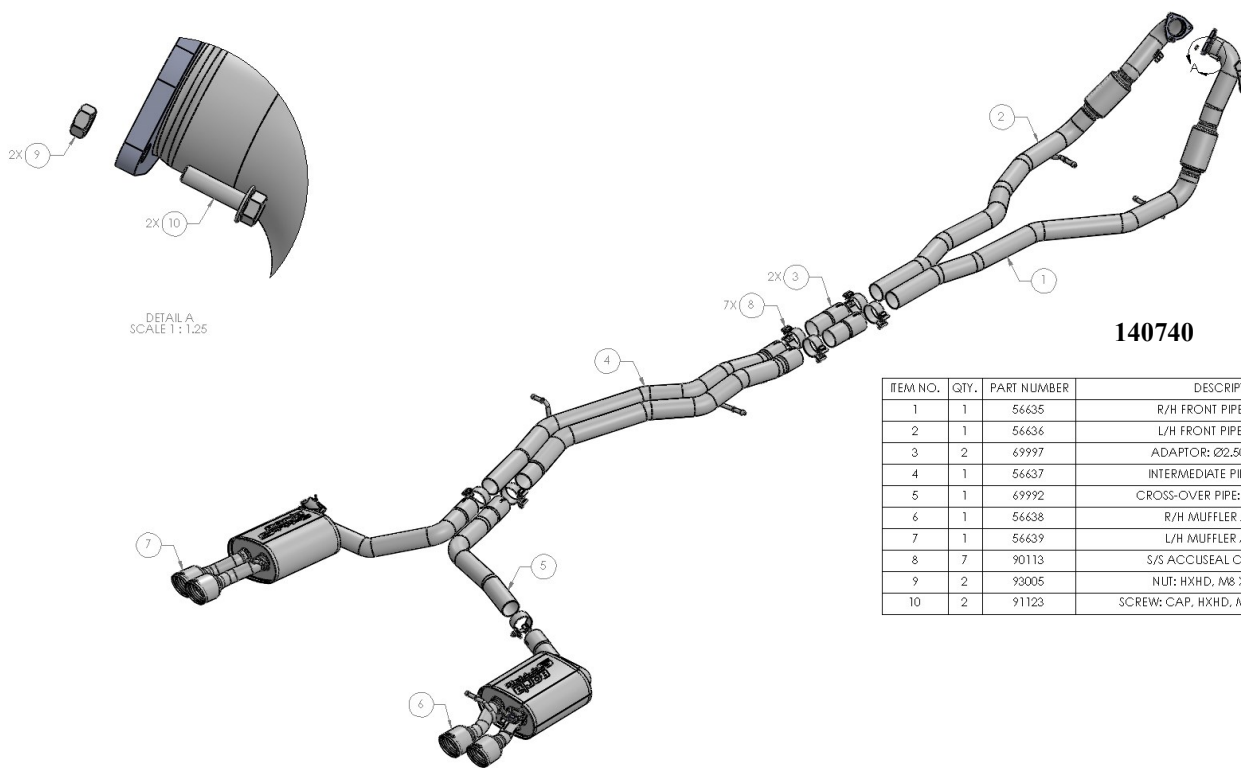

**140740**

ITEM NO.	QTY.	PART NUMBER	DESCRIPTION
1	1	56435	R/H FRONT PIPE ASSEMBLY
2	1	56436	L/H FRONT PIPE ASSEMBLY
3	2	69997	ADAPTOR: Ø2.50 X 5.75" LG.
4	1	56437	INTERMEDIATE PIPE ASSEMBLY
5	1	69992	CROSS-OVER PIPE: Ø2.50 X 28.80"
6	1	56438	R/H MUFFLER ASSEMBLY
7	1	56439	L/H MUFFLER ASSEMBLY
8	7	90113	S/S ACCUSEAL CLAMP Ø2.50
9	2	93005	NUT: HXHD, M8 X 1.25 PITCH
10	2	91123	SCREW: CAP, HXHD, M8 X 30MM, 1.25p

**Minimum Required Tool List:**

**TOOLS:**

1. 3/8” Drive Ratchet
2. 3/8” Drive Extension 3” & 6”
3. 15mm Deep Well Socket
4. 13mm Deep Well Socket
5. 8mm Deep Well Socket
6. Flat Screwdriver
7. T-50 Torx Bit
8. T-25 Torx Bit
9. Pry Bar

**SHOP SUPPLIES:**

- 1 Spray Lubricant

**Borla Performance - Bill of Materials**

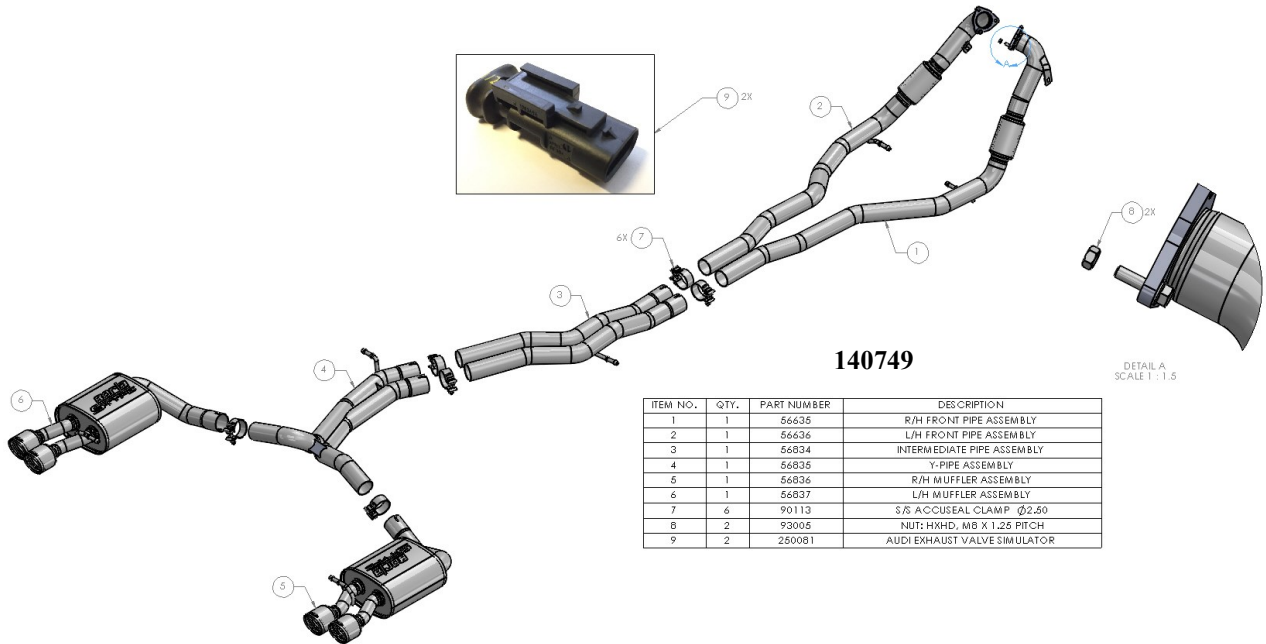

**140749**

ITEM NO.	QTY.	PART NUMBER	DESCRIPTION
1	1	56635	R/H FRONT PIPE ASSEMBLY
2	1	56636	L/H FRONT PIPE ASSEMBLY
3	1	56834	INTERMEDIATE PIPE ASSEMBLY
4	1	56835	Y-PIPE ASSEMBLY
5	1	56836	R/H MUFFLER ASSEMBLY
6	1	56837	L/H MUFFLER ASSEMBLY
7	6	90113	S/S ACCUSEAL CLAMP Ø2.50
8	2	93005	NUT: HXHD, M8 X 1.25 PITCH
9	2	260081	AUDI EXHAUST VALVE SIMULATOR

DETAIL A  
SCALE 1:1.5

**Caution!!!** *Never work on a hot exhaust system. Serious injury in the form of burns can result if the vehicle has been in use and the exhaust system is hot, allow vehicle to cool for at least 1 hour. Always wear eye protection when working under any vehicle.*

*Note: It is our recommendation that you use a hoist or hydraulic lift to facilitate the installation of your new Borla Performance Exhaust System.*

*Taking all under car safety precautions, lift the vehicle using a hoist or hydraulic lift. Once this has been done, you may begin the removal of your old exhaust system from your vehicle.*

*Note: Before removing the original exhaust system from your vehicle, please compare the parts you have received with the bill of materials provided on the previous page to assure that you have all the parts necessary for the installation of your new Borla Performance Exhaust System.*

*Note: With a used vehicle, we suggest a penetrating spray lubricant to be applied liberally to all exhaust fasteners and allowing a significant period of time for the chemical to lubricate the threads before attempting to disassemble.*

## Original Exhaust System Removal

1. Lubricate all hangers, rubber isolators, bolts and nuts.
2. Disconnect the valve actuators on R/H & L/H rear Mufflers. (See Fig. 1)
3. Remove cross-member bracket bolts and hanger bracket. Keep this assembly for reinstallation later. (See Fig. 2 & 3)
4. S5 Sportback only: remove additional cross-member assemblies near rear muffler assemblies. Keep hardware for later reinstallation.
5. Loosen and remove OEM clamps on front pipe. Keep hardware for reinstallation of your new Borla cat-back. (See Fig. 4)
6. Using a muffler stand or additional person to hold the exhaust and carefully remove from vehicle.
7. Original exhaust removed. (See Fig. 5)

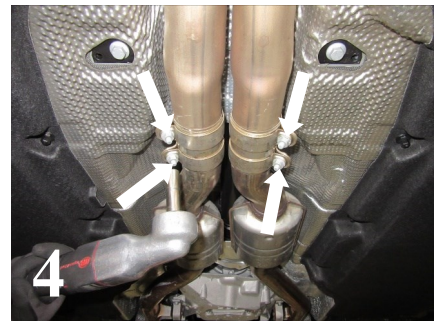
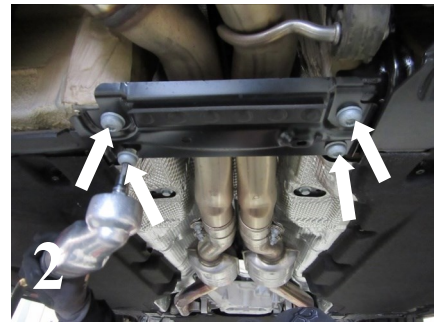



**Caution!!!** *Never work on a hot exhaust system. Serious injury in the form of burns can result if the vehicle has been in use and the exhaust system is hot, allow vehicle to cool for at least 1 hour. Always wear eye protection when working under any vehicle.*

**Note:** *It is our recommendation that you use a hoist or hydraulic lift to facilitate the installation of your new Borla Performance Exhaust System.*

**Taking all under car safety precautions, lift the vehicle using a hoist or hydraulic lift. Once this has been done, you may begin the removal of your old exhaust system from your vehicle.**

**Note:** *Before removing the original exhaust system from your vehicle, please compare the parts you have received with the bill of materials provided on the previous page to assure that you have all the parts necessary for the installation of your new Borla Performance Exhaust System.*

**Note:** *With a used vehicle, we suggest a penetrating spray lubricant to be applied liberally to all exhaust fasteners and allowing a significant period of time for the chemical to lubricate the threads before attempting to disassemble.*

## Original Exhaust System Removal (Cont'd)

7. Remove push pins and nuts from the cover under the vehicle. Keep hardware for reinstallation. (See Fig. 6)
8. Remove the R/H & L/H hanger brackets keep for reinstallation. (See Fig. 7)
9. Loosen and remove the bolts from the brackets on R/H & L/H of front pipes. (See Fig. 8)
10. Remove the engine cover for more clearance to get to the flange. (See Fig. 9)

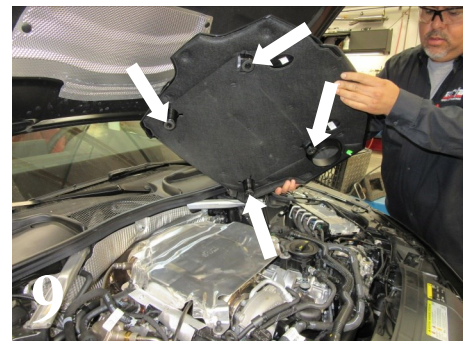
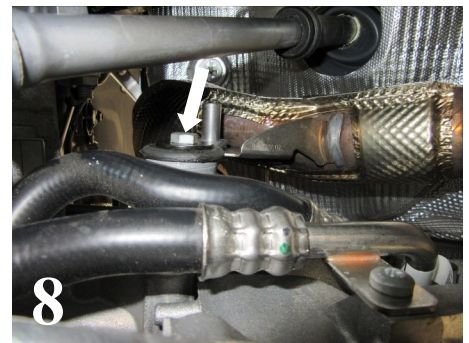
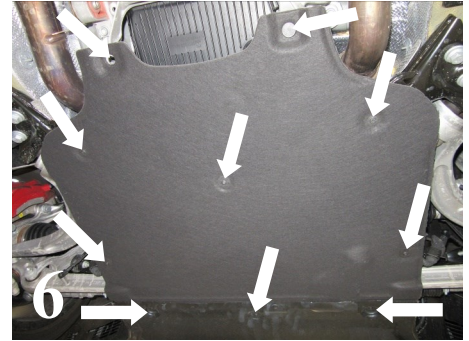

**Caution!!!** *Never work on a hot exhaust system. Serious injury in the form of burns can result if the vehicle has been in use and the exhaust system is hot, allow vehicle to cool for at least 1 hour. Always wear eye protection when working under any vehicle.*

**Note:** *It is our recommendation that you use a hoist or hydraulic lift to facilitate the installation of your new Borla Performance Exhaust System.*

**Taking all under car safety precautions, lift the vehicle using a hoist or hydraulic lift. Once this has been done, you may begin the removal of your old exhaust system from your vehicle.**

**Note:** *Before removing the original exhaust system from your vehicle, please compare the parts you have received with the bill of materials provided on the previous page to assure that you have all the parts necessary for the installation of your new Borla Performance Exhaust System.*

**Note:** *With a used vehicle, we suggest a penetrating spray lubricant to be applied liberally to all exhaust fasteners and allowing a significant period of time for the chemical to lubricate the threads before attempting to disassemble.*

## Original Exhaust System Removal (Cont'd)

11. Loosen and remove hardware on R/H & L/H front pipe flanges. Keep hardware for re-installation. (See Fig. 10)
12. Remove R/H & L/H front pipes. Keep the gaskets for reinstallation. (See Fig. 11)
13. Transfer R/H & L/H hanger brackets to your new system. (See Fig. 12)
14. Original front pipes removed. (See Fig. 13)

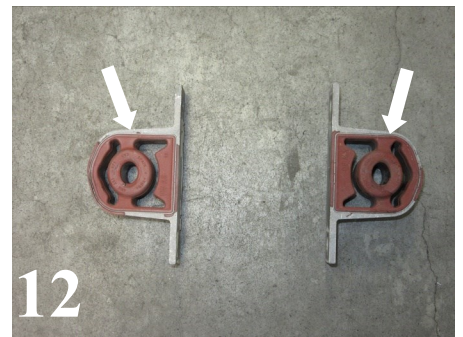

## Borla Performance Cat-Back™ Exhaust System Installation

1. Orient components on floor referencing the Bill of Materials.
2. Install L/H & R/H Front Pipe Assemblies to flanges using factory hardware. Lightly tighten hardware. (See Fig. 18)
3. **S4 ONLY:** Install Extension Adaptor (Fig. 19) inlets to Front Pipe Assembly.
4. Place clamp on the expanded ends of the Intermediate Pipe Assembly inlets and insert them into Front Pipe Assembly (or adaptor). (See Fig. 20) Do not tighten clamps.
5. Place a clamp on inlet of L/H Rear Muffler Assembly and insert into left-side of Intermediate Muffler Assembly. Do not tighten clamps.
6. Repeat STEP 4 for R/H Rear Muffler Assembly.
7. Reinstall cross-member brace using original hardware.
8. Reinstall engine cover in engine bay.
9. Check your exhaust for proper clearance under the vehicle and also for tip alignment. (See Fig. 21)
10. Begin tightening hardware at the front then moving to the rear. Tighten the Accuseal clamps 32-35 ft. lbs. torque. Tighten the flange hardware to 18-22 ft. lbs. torque.
11. Start vehicle and check for any leaks. If any leaks are found, determine cause (such as loose hardware or incorrectly positioned clamp) and repair as necessary.

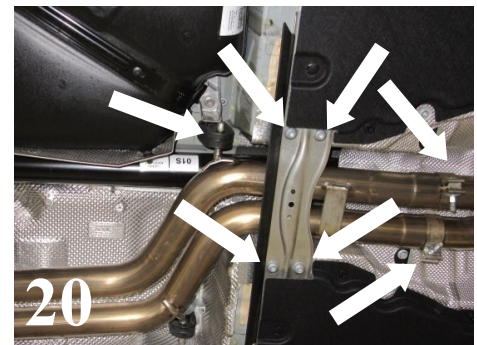
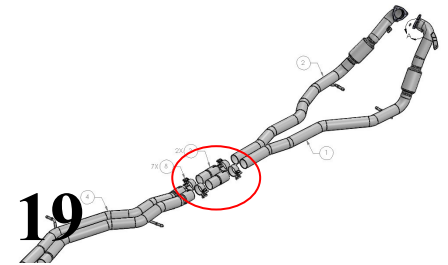
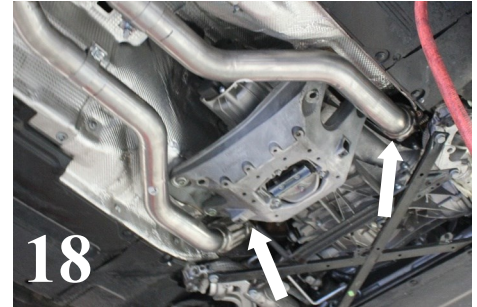

**WARNING:** Use extreme caution during installation. Torque all fasteners according to manufacturer's torque values and tightening sequence. **DO NOT** use air impact tools to tighten fasteners on Borla Performance Exhaust Systems. Use of such tools may result in bent flanges or gasket contact areas leading to exhaust leaks.

**NOTE:** When you first start your vehicle after the installation of your new Borla Performance Exhaust System, there may be some smoke and fumes coming from the system. This is a protective oil based coating used in the manufacturing of mandrel bent performance exhaust tubing. This is not a problem and will disappear within a very short period of time after the exhaust has reached normal operating temperatures.