

Exhaust System Installation for Global Ford Ranger PN-140728



******* Please compare the parts in the box with the bill of materials provided *****
to assure that you have all the parts necessary for this installation.**

These instructions have been written to help you with the installation of your Borla Performance Exhaust System. Please read this document completely before beginning the installation of your system.

Thank you for purchasing a Borla Performance Cat-Back™ Exhaust System.

Borla Performance Cat-Back™ Exhaust System (PN-140728) is designed for the Global Ford Ranger equipped with a 3.2L inline 5-cylinder diesel engine, automatic or manual transmissions.

Borla Performance Industries recommends that an exhaust shop or professional after market parts installer, who has all the necessary equipment, tools and experienced personnel needed for proper installation, should perform the installation of this system. However, if you decide to perform the installation, we recommend someone should help you. Ensure the installer uses all under car safety precautions including eye protection.

Please take time to read and understand the following...

By installing your Borla Performance Exhaust System, you indicate that you have read this document and you agree with the terms stated below.

It is the responsibility of the purchaser to follow all installation instruction guidelines and safety procedures supplied with your Borla Performance Exhaust System.

Borla Performance Industries assumes no responsibility for damages occurring from misuse, abuse, improper installation, improper operation, lack of responsible care, or all previously stated reasons resulting from incompatibility with other manufacturer's products and/or systems.

Included with your Borla Performance Exhaust System is a warranty card. Please read it carefully before you begin any work on your vehicle. If you should have any questions regarding our warranty policy, installation, or any other matter pertaining to your new performance exhaust system, please give us a call at the number provided on the warranty card.

Minimum Required Tool List:

TOOLS:

1. 3/8" Drive Ratchet
2. 3/8" Drive Extension 3"
3. 15mm Deep Well Socket
4. 15mm Wrench
5. 13mm Socket
6. 13mm Wrench
7. Pry Bar

SHOP SUPPLIES:

- 1 Spray Lubricant

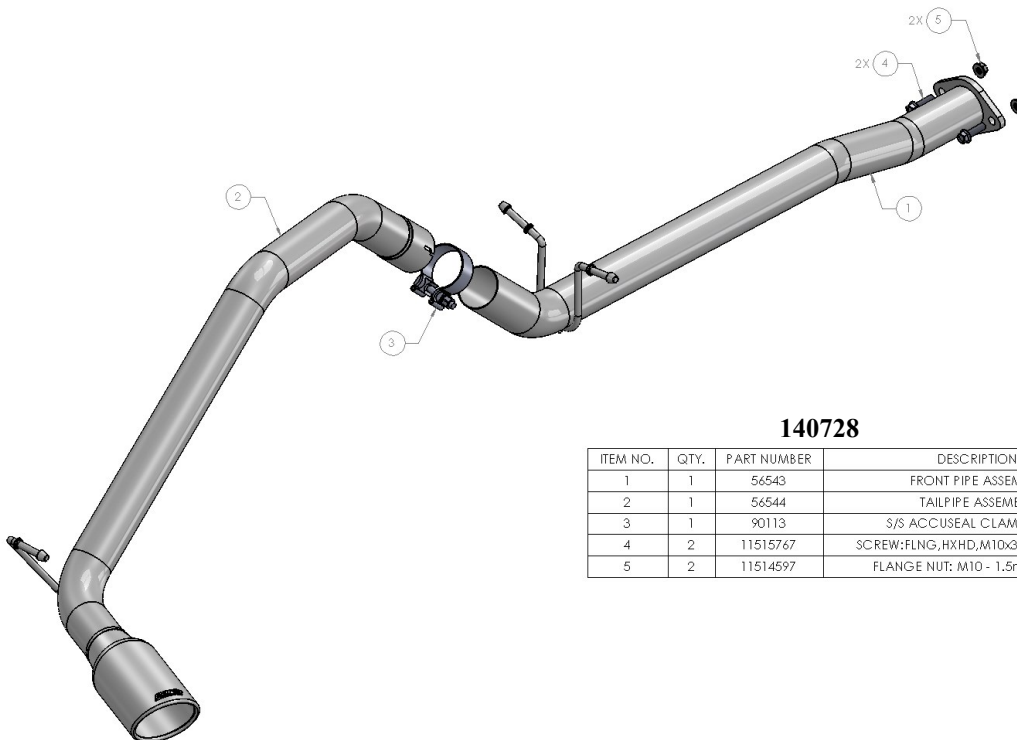

140728

ITEM NO.	QTY.	PART NUMBER	DESCRIPTION
1	1	56543	FRONT PIPE ASSEMBLY
2	1	56544	TAILPIPE ASSEMBLY
3	1	90113	S/S ACCUSEAL CLAMP Ø2.50
4	2	11515767	SCREW:FLNG,HXHD,M10x35mm,1.50mP
5	2	11514597	FLANGE NUT: M10 - 1.5mm Thread