

Installation Instructions for Challenger R/T: 140713, 140714, 140715, 140716 Charger R/T: 140722, 140723, 140724, 140725



******* Please compare the parts in the box with the bill of materials provided *****
to assure that you have all the parts necessary for this installation.**

These instructions have been written to help you with the installation of your Borla Performance Exhaust System. Please read this document completely before beginning the installation of your system.

Thank you for purchasing a Borla Performance Cat-Back™ Exhaust System.

Borla Performance Cat-Back™ Exhaust Systems (PN's-140713, 140714, 140715, 140716) are designed for the Dodge Challenger R/T equipped with a 5.7L V-8 engine, automatic or manual transmissions.

Borla Performance Cat-Back™ Exhaust Systems (PN's-140722, 140723, 140724, 140725) are designed for the Dodge Charger R/T equipped with a 5.7L V-8 engine, automatic or manual transmissions.

Borla Performance Industries recommends that an exhaust shop or professional after market parts installer perform the installation of this system. However, if you decide to perform the installation on your own it is recommended that two people are used. This installation should not be performed by one person due to the risk of injury. Ensure the installers use all under car safety precautions including eye protection.

Please take time to read and understand the following...

By installing your Borla Performance Exhaust System, you indicate that you have read this document and you agree with the terms stated below.

It is the responsibility of the purchaser to follow all installation instruction guidelines and safety procedures supplied with your Borla Performance Exhaust System.

Borla Performance Industries assumes no responsibility for damages occurring from misuse, abuse, improper installation, improper operation, lack of responsible care, or all previously stated reasons resulting from incompatibility with other manufacturer's products and/or systems.

Included with your Borla Performance Exhaust System is a warranty card. Please read it carefully before you begin any work on your vehicle. If you should have any questions regarding our warranty policy, installation, or any other matter pertaining to your new Borla Performance Exhaust System, please give us a call at the number provided on the warranty card.

Minimum Required Tool List:

TOOLS:

1. 3/8” Drive Ratchet
2. 3/8” Drive Extension 3”
3. 15mm Socket
4. 13mm Socket
5. Pry Bar

SHOP SUPPLIES:

- 1 Spray Lubricant

Borla Performance Cat-back™ Bill of Materials

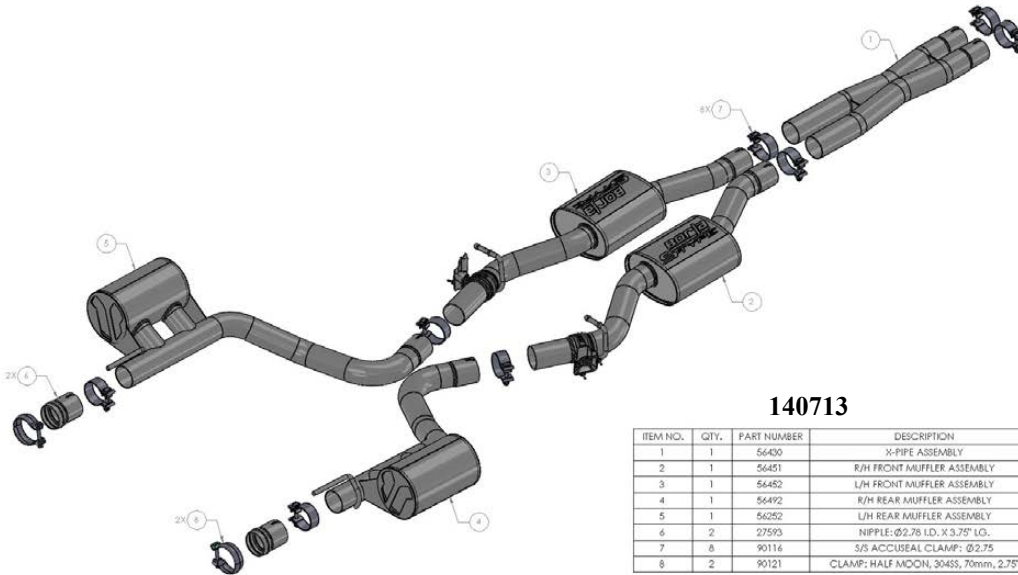

140713

ITEM NO.	QTY.	PART NUMBER	DESCRIPTION
1	1	56430	X-PIPE ASSEMBLY
2	1	56451	R/H FRONT MUFFLER ASSEMBLY
3	1	56452	L/H FRONT MUFFLER ASSEMBLY
4	1	56492	R/H REAR MUFFLER ASSEMBLY
5	1	56252	L/H REAR MUFFLER ASSEMBLY
6	2	27593	NIPPLE: Ø2.78 I.D. X 3.75" LG.
7	8	90116	S/S ACCUSEAL CLAMP: Ø2.75
8	2	90121	CLAMP: HALF MOON, 304SS, 70mm, 2.75"

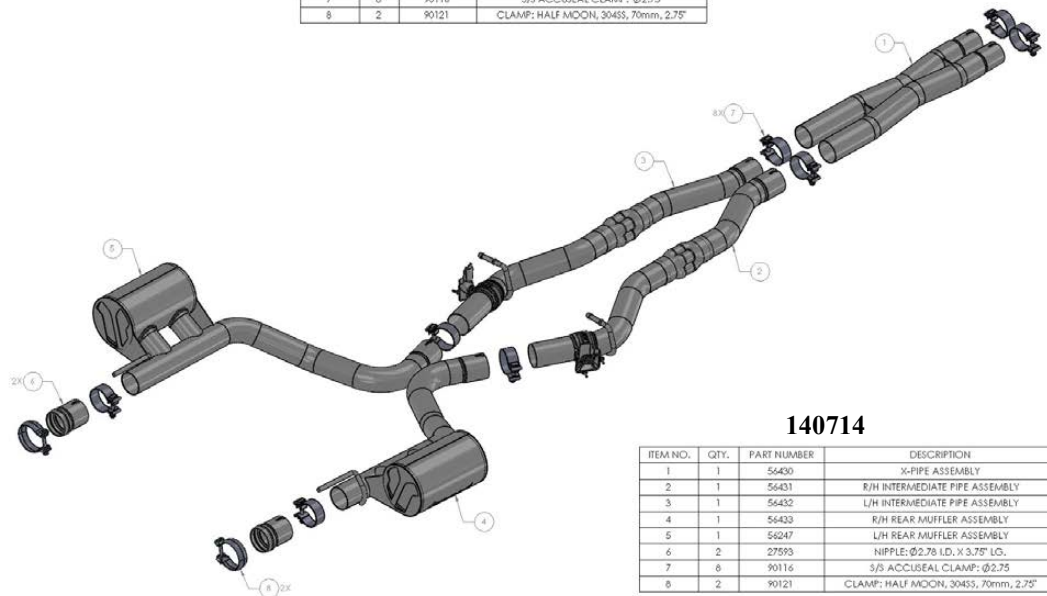

140714

ITEM NO.	QTY.	PART NUMBER	DESCRIPTION
1	1	56430	X-PIPE ASSEMBLY
2	1	56431	R/H INTERMEDIATE PIPE ASSEMBLY
3	1	56432	L/H INTERMEDIATE PIPE ASSEMBLY
4	1	56433	R/H REAR MUFFLER ASSEMBLY
5	1	56247	L/H REAR MUFFLER ASSEMBLY
6	2	27593	NIPPLE: Ø2.78 I.D. X 3.75" LG.
7	8	90116	S/S ACCUSEAL CLAMP: Ø2.75
8	2	90121	CLAMP: HALF MOON, 304SS, 70mm, 2.75"

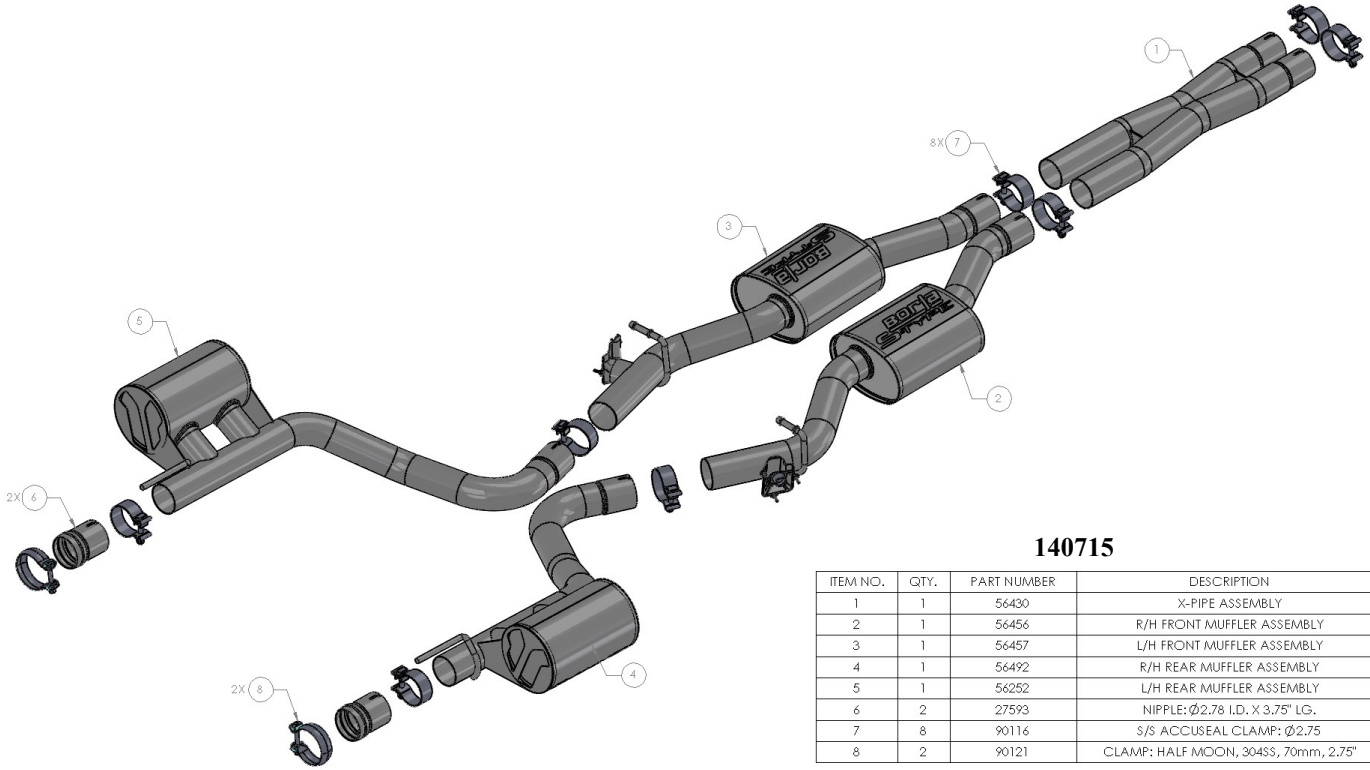

140715

ITEM NO.	QTY.	PART NUMBER	DESCRIPTION
1	1	56430	X-PIPE ASSEMBLY
2	1	56456	R/H FRONT MUFFLER ASSEMBLY
3	1	56457	L/H FRONT MUFFLER ASSEMBLY
4	1	56492	R/H REAR MUFFLER ASSEMBLY
5	1	56252	L/H REAR MUFFLER ASSEMBLY
6	2	27593	NIPPLE: Ø2.78 I.D. X 3.75" LG.
7	8	90116	S/S ACCUSEAL CLAMP: Ø2.75
8	2	90121	CLAMP: HALF MOON, 304SS, 70mm, 2.75"

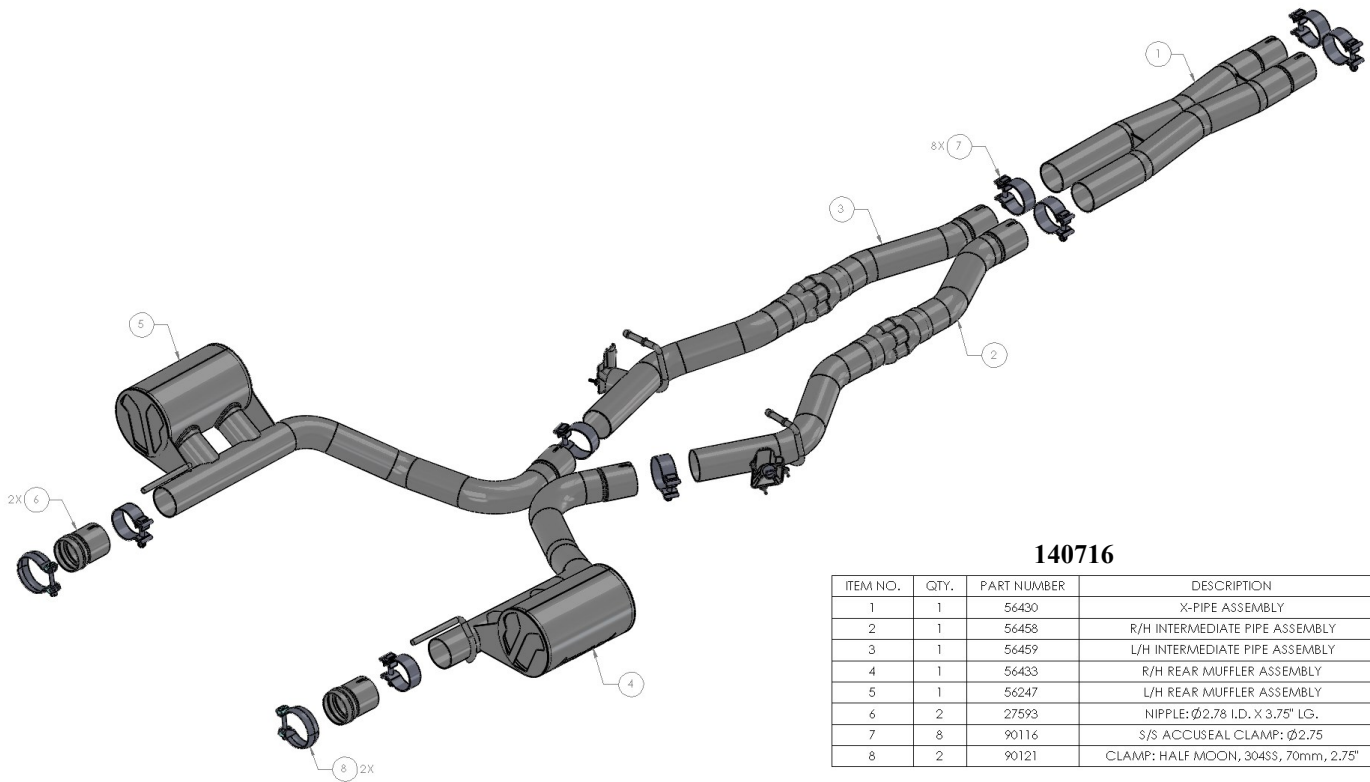

140716

ITEM NO.	QTY.	PART NUMBER	DESCRIPTION
1	1	56430	X-PIPE ASSEMBLY
2	1	56458	R/H INTERMEDIATE PIPE ASSEMBLY
3	1	56459	L/H INTERMEDIATE PIPE ASSEMBLY
4	1	56433	R/H REAR MUFFLER ASSEMBLY
5	1	56247	L/H REAR MUFFLER ASSEMBLY
6	2	27593	NIPPLE: Ø2.78 I.D. X 3.75" LG.
7	8	90116	S/S ACCUSEAL CLAMP: Ø2.75
8	2	90121	CLAMP: HALF MOON, 304SS, 70mm, 2.75"

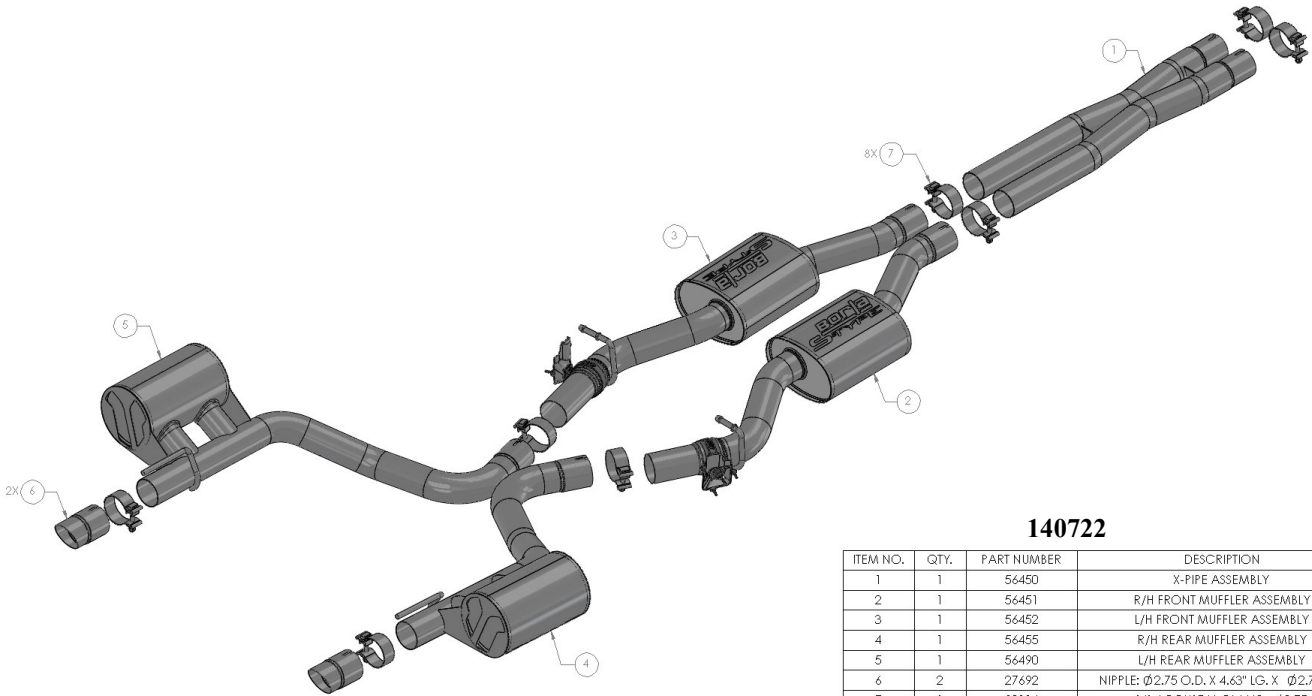

140722

ITEM NO.	QTY.	PART NUMBER	DESCRIPTION
1	1	56450	X-PIPE ASSEMBLY
2	1	56451	R/H FRONT MUFFLER ASSEMBLY
3	1	56452	L/H FRONT MUFFLER ASSEMBLY
4	1	56455	R/H REAR MUFFLER ASSEMBLY
5	1	56490	L/H REAR MUFFLER ASSEMBLY
6	2	27692	NIPPLE: Ø2.75 O.D., X 4.63" LG, X Ø2.78 I.D.
7	8	90116	S/S ACCUSEAL CLAMP: Ø2.75

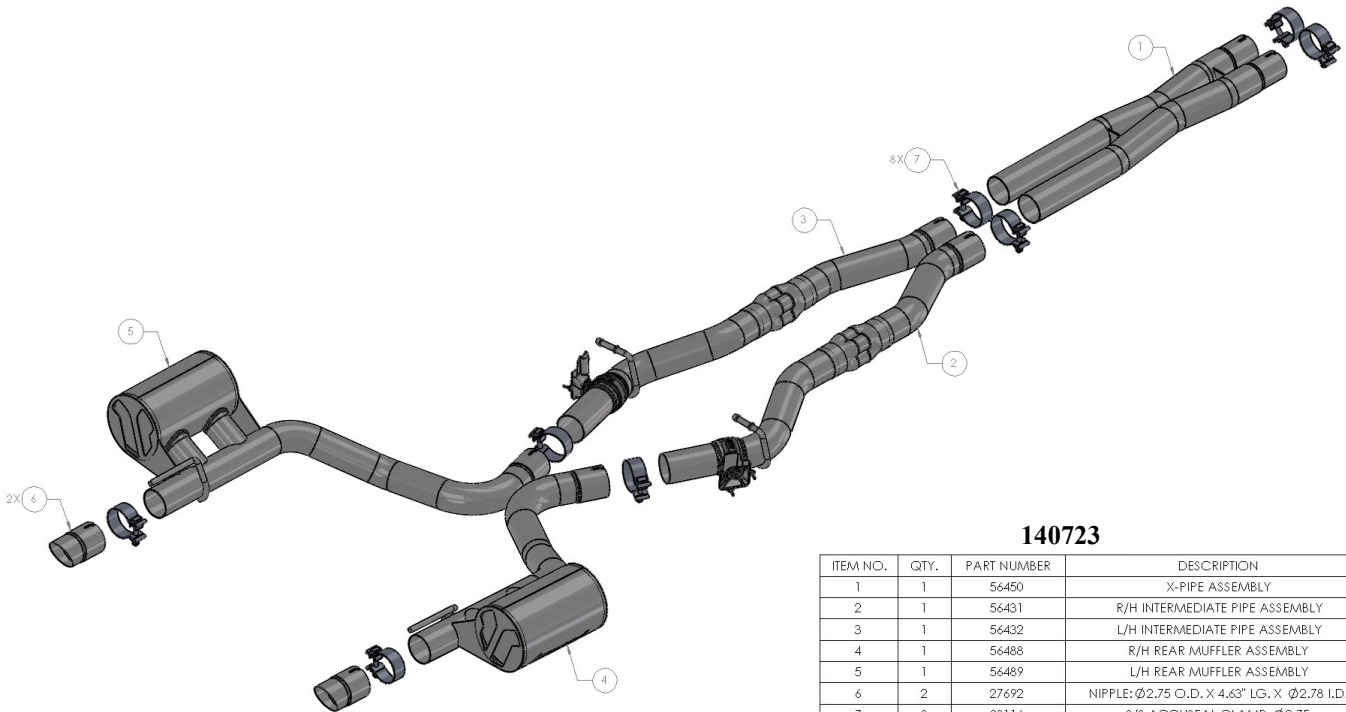

140723

ITEM NO.	QTY.	PART NUMBER	DESCRIPTION
1	1	56450	X-PIPE ASSEMBLY
2	1	56431	R/H INTERMEDIATE PIPE ASSEMBLY
3	1	56432	L/H INTERMEDIATE PIPE ASSEMBLY
4	1	56488	R/H REAR MUFFLER ASSEMBLY
5	1	56489	L/H REAR MUFFLER ASSEMBLY
6	2	27692	NIPPLE: Ø2.75 O.D., X 4.63" LG, X Ø2.78 I.D.
7	8	90116	S/S ACCUSEAL CLAMP: Ø2.75

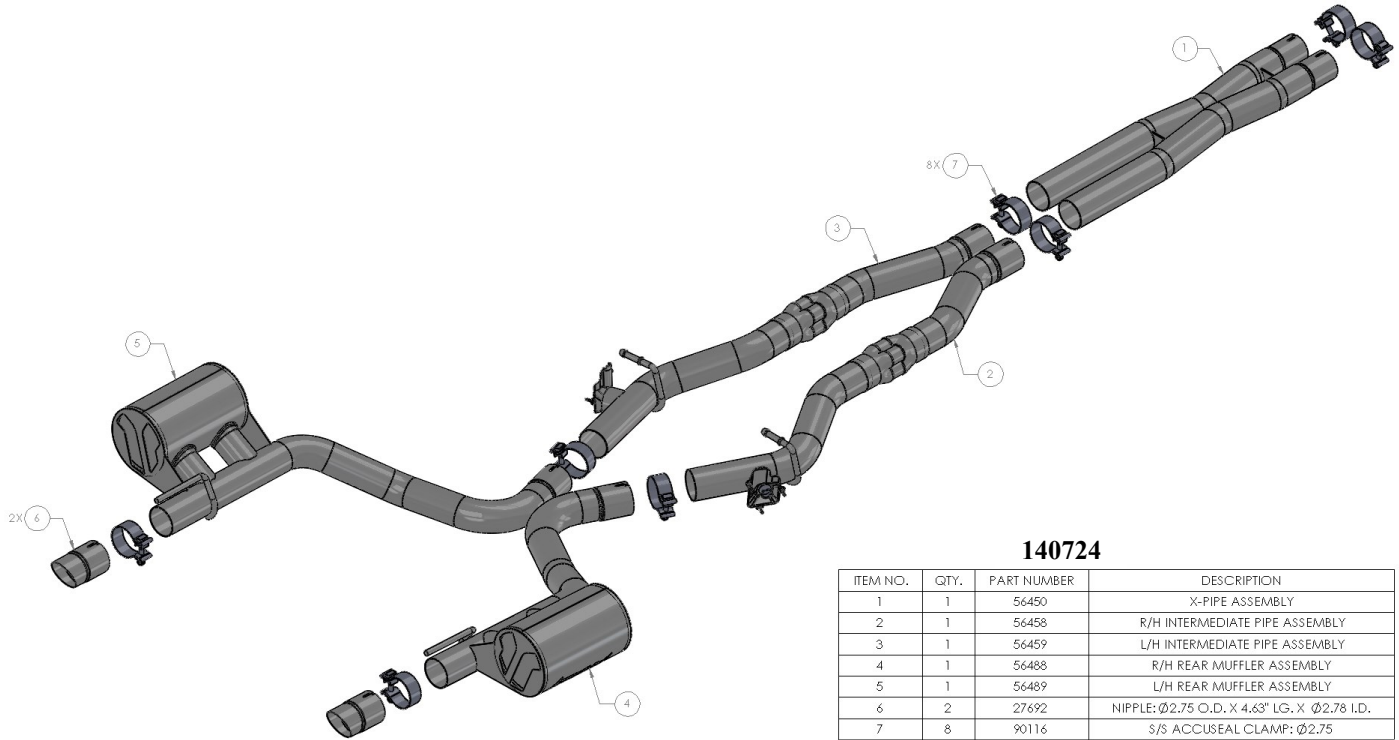

140724

ITEM NO.	QTY.	PART NUMBER	DESCRIPTION
1	1	56450	X-PIPE ASSEMBLY
2	1	56458	R/H INTERMEDIATE PIPE ASSEMBLY
3	1	56459	L/H INTERMEDIATE PIPE ASSEMBLY
4	1	56488	R/H REAR MUFFLER ASSEMBLY
5	1	56489	L/H REAR MUFFLER ASSEMBLY
6	2	27692	NIPPLE: Ø2.75 O.D. X 4.63" LG. X Ø2.78 I.D.
7	8	90116	S/S ACCUSEAL CLAMP: Ø2.75

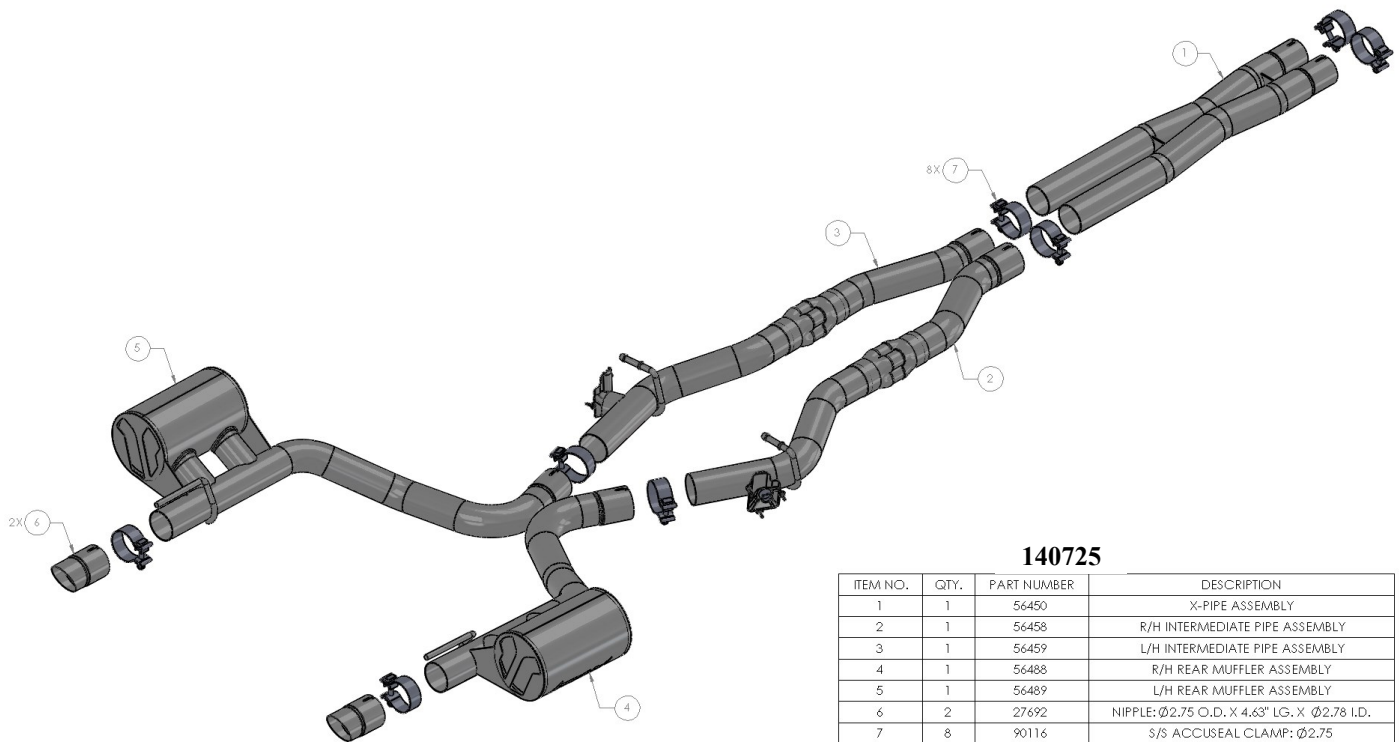

140725

ITEM NO.	QTY.	PART NUMBER	DESCRIPTION
1	1	56450	X-PIPE ASSEMBLY
2	1	56458	R/H INTERMEDIATE PIPE ASSEMBLY
3	1	56459	L/H INTERMEDIATE PIPE ASSEMBLY
4	1	56488	R/H REAR MUFFLER ASSEMBLY
5	1	56489	L/H REAR MUFFLER ASSEMBLY
6	2	27692	NIPPLE: Ø2.75 O.D. X 4.63" LG. X Ø2.78 I.D.
7	8	90116	S/S ACCUSEAL CLAMP: Ø2.75

Caution!!! *Never work on a hot exhaust system. Serious injury in the form of burns can result if the vehicle has been in use and the exhaust system is hot, allow vehicle to cool for at least 1 hour. Always wear eye protection when working under any vehicle.*

Note: *It is our recommendation that you use a hoist or hydraulic lift to facilitate the installation of your new Borla Performance Exhaust System.*

Taking all under car safety precautions, lift the vehicle using a hoist or hydraulic lift. Once this has been done, you may begin the removal of your old exhaust system from your vehicle.

Note: *Before removing the original exhaust system from your vehicle, please compare the parts you have received with the bill of materials provided on the previous page to assure that you have all the parts necessary for the installation of your new Borla Performance Exhaust System.*

Note: *With a used vehicle, we suggest a penetrating spray lubricant to be applied liberally to all exhaust fasteners and allowing a significant period of time for the chemical to lubricate the threads before attempting to disassemble.*

Original Exhaust System Removal

1. Unclip and remove the ground strap located on the right-side rear muffler.
2. Remove bolts on rear left-side and rear right-side **hanger brackets**. Keep hardware for re-installation. (See Fig. 1)
3. Remove (2) support brackets. Keep the hardware for re-installation. (See Fig. 2)
4. Disconnect the wire harnesses from the OE actuator on both left-side and right-side mid-section pipes. (See Fig. 3)
5. Loosen the clamps located in front of the x-pipe assembly. (See Fig. 4)
6. Use a muffler stand or an additional person to support the muffler assembly. Remove the hangers from the rubber isolators and remove the muffler assembly from the vehicle and place on the ground for Step 6.
7. Remove both electronic actuators from the OE system. These will later be transferred to your new system.
8. OE exhaust system removed. (See Fig. 5)

WARNING: *Use extreme caution during installation. Torque all fasteners according to manufacturer's torque values and tightening sequence. **DO NOT** use air impact tools to tighten fasteners on Borla Performance Exhaust Systems. Use of such tools may result in bent flanges or gasket contact areas leading to exhaust leaks.*

NOTE: *When you first start your vehicle after the installation of your new Borla Performance Exhaust System, there may be some smoke and fumes coming from the system. This is a protective oil based coating used in the manufacturing of mandrel bent performance exhaust tubing. This is not a problem and will disappear within a very short period of time after the exhaust has reached normal operating temperatures.*

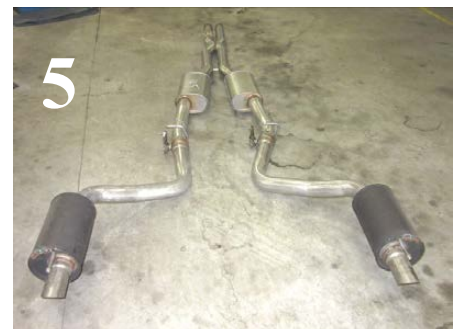
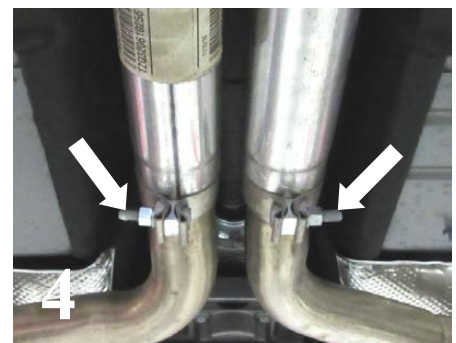
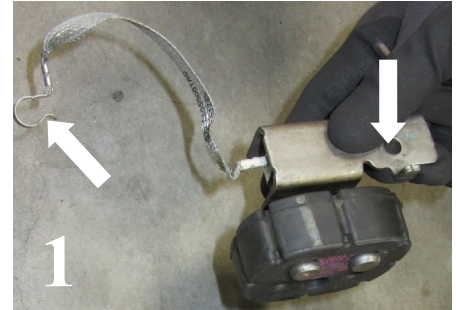

Borla Performance Cat-Back™ Exhaust System Installation

1. Reference pages 2-5 for your exhaust components. Arrange components on the ground next to your removed OE exhaust for installation reference.
2. Place a clamp over each expanded end of the **X-pipe Assembly** and insert into factory front pipe. Do not tighten the clamps. (See Fig. 4)
3. Place a clamp over the expanded end of **R/H Intermediate Pipe Assembly** and insert to outlet of **X-Pipe Assembly**. Insert hanger into rubber isolator. Do not tighten the clamps. (See Fig. 5)
4. Repeat STEP 2 for **L/H Intermediate Pipe Assembly**.
5. Place clamp over the expanded end of **L/H Rear Muffler Assembly**. Insert hanger into (removed) OE left-side hanger rubber isolator. Insert inlet of **L/H Rear Muffler Assembly** to outlet of **L/H Intermediate Pipe Assembly**. Install hanger bracket to vehicle and tighten bolt. (See Fig. 6)
6. Repeat STEP 5 for **R/H Rear Muffler Assembly** to **R/H Intermediate Pipe Assembly**. On vehicle right-side clip the ground strap to the hanger to hold the bracket. (See Fig. 7)
7. Install **Nipple** to left-side and right-side Rear Muffler Assemblies with provided clamps. Do not tighten clamps.
8. Check your exhaust system for proper clearance under the vehicle and also for tip centering to tip. (See Fig. 8, quad tips) v
9. Once position has been determined to be correct, begin tightening at X-Pipe and work back to Nipples; tighten the Accuseal clamps to 32-35 ft. lbs.
10. Before starting your vehicle, make sure to check all wires, hoses, brake lines, body parts and tires for safe clearance from the exhaust system.
11. Start vehicle and check for any leaks. If any leaks are found, determine cause (such as loose or incorrectly positioned clamp) and repair as necessary.

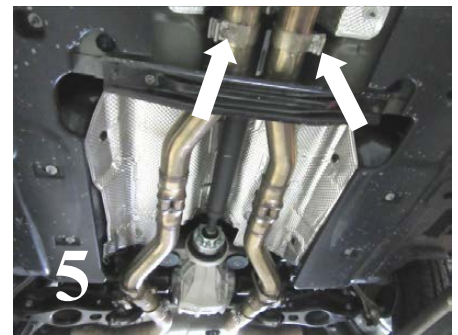

WARNING: Use extreme caution during installation. Torque all fasteners according to manufacturer's torque values and tightening sequence. **DO NOT** use air impact tools to tighten fasteners on Borla Performance Exhaust Systems. Use of such tools may result in bent flanges or gasket contact areas leading to exhaust leaks.

NOTE: When you first start your vehicle after the installation of your new Borla Performance Exhaust System, there may be some smoke and fumes coming from the system. This is a protective oil based coating used in the manufacturing of mandrel bent performance exhaust tubing. This is not a problem and will disappear within a very short period of time after the exhaust has reached normal operating temperatures.