

## Exhaust System Installation for Audi S5, S4, and S6 PNs-140391, 140403, 140704



**\*\*\*\*\* Please compare the parts in the box with the bill of materials provided \*\*\*\*\*  
to assure that you have all the parts necessary for this installation.**

These instructions have been written to help you with the installation of your Borla Performance Exhaust System. Please read this document completely before beginning the installation of your system.

### Thank you for purchasing a Borla Performance Cat-Back™ Exhaust System.

**Borla Performance Cat-Back™ Exhaust System (PN-140391) is designed for the Audi S5 equipped with a 3.0L Supercharged V6 engine, automatic or manual transmissions.**

**Borla Performance Cat-Back™ Exhaust System (PN-140403) is designed for the Audi S4 equipped with a 3.0L Supercharged V6 engine, automatic or manual transmissions.**

**Borla Performance Cat-Back™ Exhaust System (PN-140704) is designed for the Audi S6 equipped with a 4.0L Turbo-charged V8 engine, automatic transmission.**

Borla Performance Industries recommends that an exhaust shop or professional after market parts installer, who has all the necessary equipment, tools and experienced personnel needed for proper installation, should perform the installation of this system. However, if you decide to perform the installation, we recommend someone should help you. Ensure the installer uses all under car safety precautions including eye protection.

### *Please take time to read and understand the following...*

By installing your Borla Performance Exhaust System, you indicate that you have read this document and you agree with the terms stated below.

It is the responsibility of the purchaser to follow all installation instruction guidelines and safety procedures supplied with your Borla Performance Exhaust System.

Borla Performance Industries assumes no responsibility for damages occurring from misuse, abuse, improper installation, improper operation, lack of responsible care, or all previously stated reasons resulting from incompatibility with other manufacturer's products and/or systems.

Included with your Borla Performance Exhaust System is a warranty card. Please read it carefully before you begin any work on your vehicle. If you should have any questions regarding our warranty policy, installation, or any other matter pertaining to your new Borla Performance Exhaust System, please give us a call at the number provided on the warranty card.

**Minimum Required Tool List:**

**TOOLS:**

1. 3/8" Drive Ratchet
2. 3/8" Drive Extension 3" & 6"
3. 15mm Deep Well Socket
4. 16mm Deep Well Socket
5. 8mm Socket
6. Pry Bar

**SHOP SUPPLIES:**

- 1 Spray Lubricant

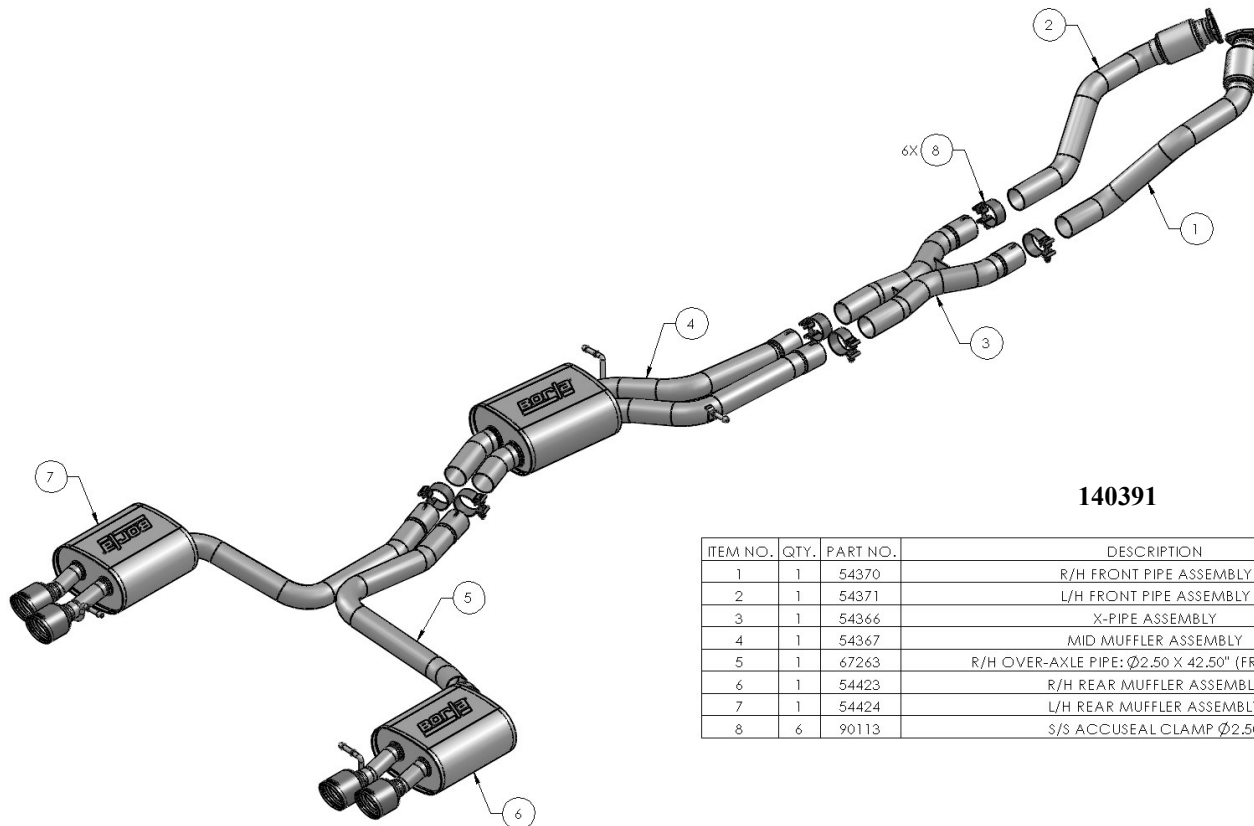

**140391**

ITEM NO.	QTY.	PART NO.	DESCRIPTION
1	1	54370	R/H FRONT PIPE ASSEMBLY
2	1	54371	L/H FRONT PIPE ASSEMBLY
3	1	54366	X-PIPE ASSEMBLY
4	1	54367	MID MUFFLER ASSEMBLY
5	1	67263	R/H OVER-AXLE PIPE: Ø2.50 X 42.50" (FROM 80027)
6	1	54423	R/H REAR MUFFLER ASSEMBLY
7	1	54424	L/H REAR MUFFLER ASSEMBLY
8	6	90113	S/S ACCUSEAL CLAMP Ø2.50

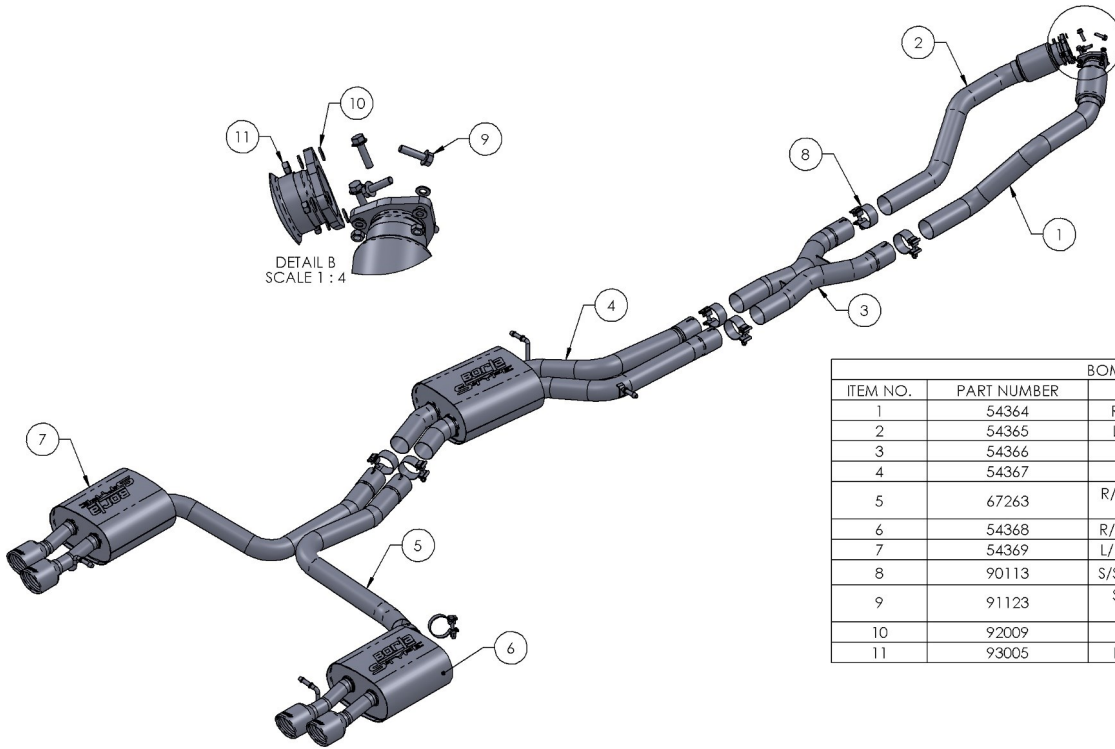

**140403**

BOM Table			
ITEM NO.	PART NUMBER	DESCRIPTION	QTY.
1	54364	R/H FRONT PIPE ASSEMBLY	1
2	54365	L/H FRONT PIPE ASSEMBLY	1
3	54366	X-PIPE ASSEMBLY	1
4	54367	MID MUFFLER ASSEMBLY	1
5	67263	R/H OVER-AXLE PIPE: Ø2.50 X 42.50" (FROM 80027)	1
6	54368	R/H REAR MUFFLER ASSEMBLY	1
7	54369	L/H REAR MUFFLER ASSEMBLY	1
8	90113	S/S ACCUSEAL CLAMP Ø2.50	7
9	91123	SCREW: CAP, HXHD, M8 X 30MM, 1.25p	6
10	92009	WASHER:FLAT, M8	12
11	93005	NUT:HXHD, M8-1.25 PITCH	6

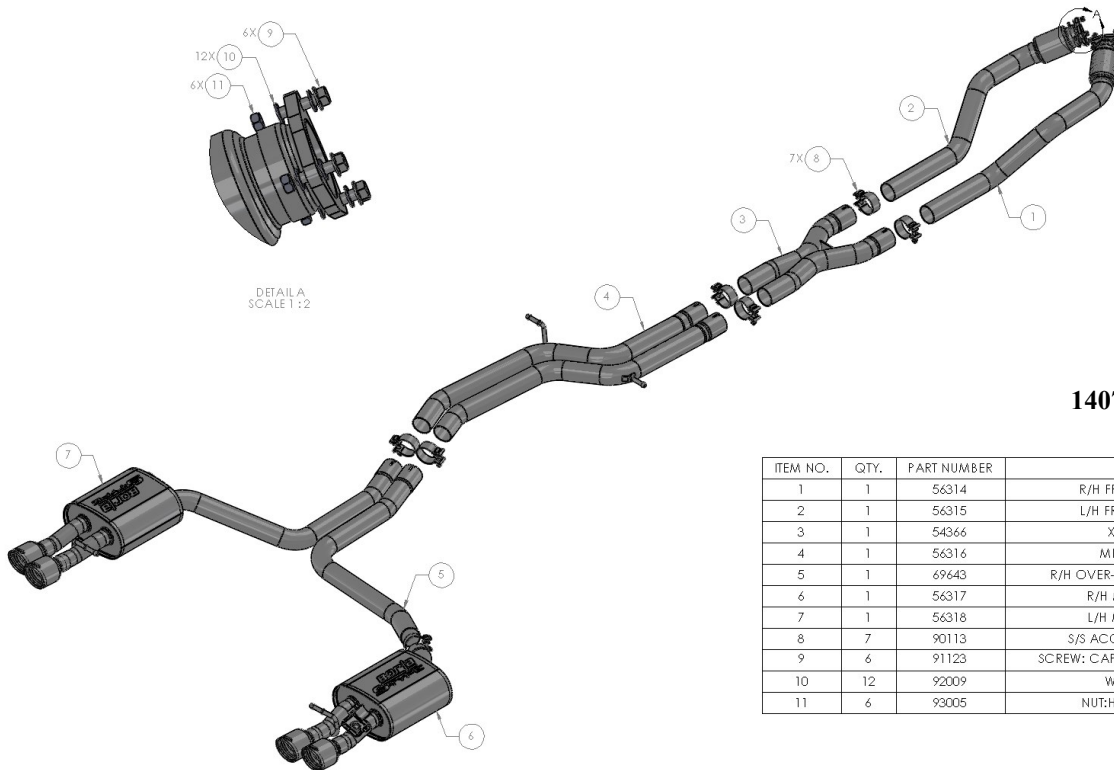

**140704**

ITEM NO.	QTY.	PART NUMBER	DESCRIPTION
1	1	56314	R/H FRONT PIPE ASSEMBLY
2	1	56315	L/H FRONT PIPE ASSEMBLY
3	1	54366	X-PIPE ASSEMBLY
4	1	56316	MID PIPE ASSEMBLY
5	1	69643	R/H OVER-AXLE PIPE: Ø2.50 X 46.42"
6	1	56317	R/H MUFFLER ASSEMBLY
7	1	56318	L/H MUFFLER ASSEMBLY
8	7	90113	S/S ACCUSEAL CLAMP Ø2.50
9	6	91123	SCREW: CAP, HXHD, M8 X 30MM, 1.25p
10	12	92009	WASHER:FLAT, M8
11	6	93005	NUT:HXHD, M8-1.25 PITCH

**Caution!!!** *Never work on a hot exhaust system. Serious injury in the form of burns can result. If the vehicle has been in use and the exhaust system is hot, allow vehicle to cool for at least 1 hour. Always wear eye protection when working under any vehicle.*

**Note:** *It is our recommendation that you use a hoist or hydraulic lift to facilitate the installation of your new Borla Performance Exhaust System.*

**Taking all under car safety precautions, lift the vehicle using a hoist or hydraulic lift. Once this has been done, you may begin the removal of your old exhaust system from your vehicle.**

**Note:** *Before removing the original exhaust system from your vehicle, please compare the parts you have received with the bill of materials provided on the previous page to assure that you have all the parts necessary for the installation of your new Borla Performance Exhaust System.*

**Note:** *With a used vehicle, we suggest a penetrating spray lubricant to be applied liberally to all exhaust fasteners and allowing a significant period of time for the chemical to lubricate the threads before attempting to disassemble.*

## Original Exhaust System Removal

1. Loosen and remove hardware on front pipe flanges. Keep hardware for re-installation of your new Borla cat-back. (See Fig. 1).
2. Remove cross-member bracket bolts. Keep this assembly for reinstallation later. (See Fig. 2)
3. For the Audi S6 disconnect the simulators on R/H & L/H rear mufflers.
4. Support exhaust system with muffler stands. Starting from front and working backwards, carefully remove hangers from rubber isolators and remove factory exhaust as shown. (See Figs. 3 & 4)

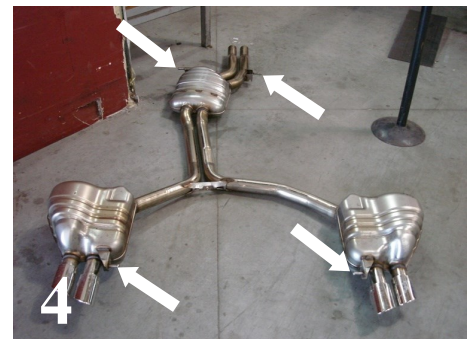
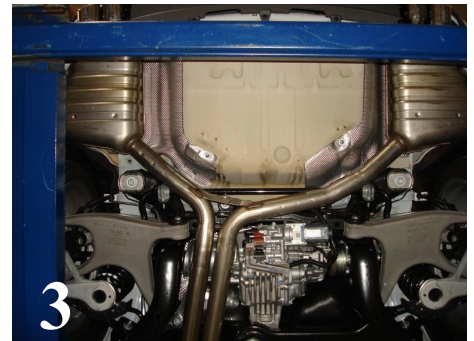
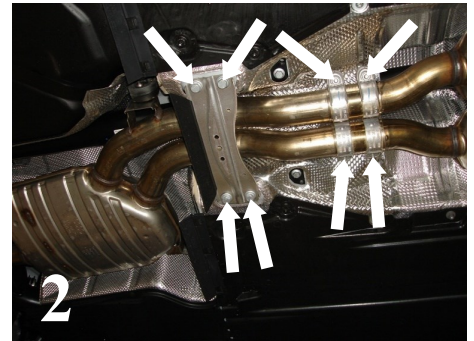
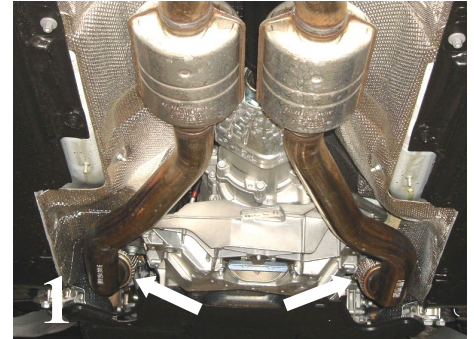



## Borla Performance Cat-Back™ Exhaust System Installation

1. Reference components and layout on pages 2-3.
2. Install **L/H & R/H Front Pipe Assemblies** to front flanges using factory hardware. Lightly tighten hardware. (See Fig. 5)
3. Place a clamp on both expanded ends of the **X-Pipe Assembly** and insert them into **Front Pipe Assembly outlets**. (See Fig. 6) Do not tighten clamps.
4. Place clamp on the expanded ends of the **Mid Muffler Assembly** inlets and insert them into **X-Pipe Assembly outlets**. Do not tighten clamps.
5. Place a clamp on inlet of **L/H Rear Muffler Assembly** and insert into **L/H Mid Muffler Assembly**. (See Fig. 8) Do not tighten clamps.
6. Repeat STEP 6 for **R/H Rear Muffler Assembly**.
7. Reinstall cross-member brace using original hardware. (See Fig. 7)
8. Check your exhaust for proper clearance under the vehicle and also for tip alignment. (See Fig. 8)
9. Begin tightening hardware at the front then moving to the rear. Tighten the Accuseal clamps 32-35 ft. lbs. torque. Tighten the flange hardware to 18-22 ft. lbs. torque.
10. Start vehicle and check for any leaks. If any leaks are found, determine cause (such as loose hardware or incorrectly positioned clamp) and repair as necessary.

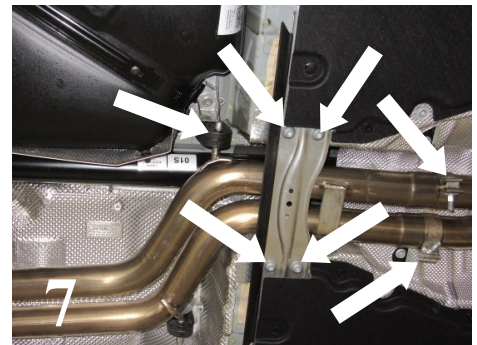
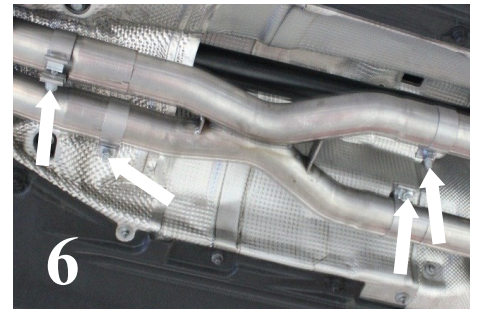
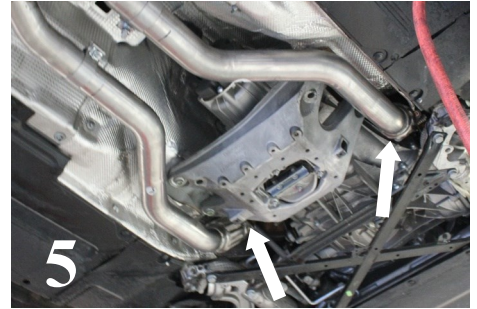

**WARNING:** Use extreme caution during installation. Torque all fasteners according to manufacturer's torque values and tightening sequence. **DO NOT** use air impact tools to tighten fasteners on Borla Performance Exhaust Systems. Use of such tools may result in bent flanges or gasket contact areas leading to exhaust leaks.

**NOTE:** When you first start your vehicle after the installation of your new Borla Performance Exhaust System, there may be some smoke and fumes coming from the system. This is a protective oil based coating used in the manufacturing of mandrel bent performance exhaust tubing. This is not a problem and will disappear within a very short period of time after the exhaust has reached normal operating temperatures.