

## Installation for Ford Mustang GT PNs 11951\*, 11951BC\*, 11953, 11953BC



**\*\*\*\*\* Please compare the parts in the box with the bill of materials provided \*\*\*\*\*  
to assure that you have all the parts necessary for this installation.**

These instructions have been written to help you with the installation of your Borla Performance exhaust system. Please read this document completely before beginning the installation of your system.

Thank you for purchasing a Borla Performance exhaust system.

Borla Performance Exhaust Systems (PNs 11951\*, 11951BC\*, 11953, 11953BC) are designed for the Ford Mustang GT equipped with a 5.0L V8 engine and automatic or manual transmissions.

### **\*Equipped with active valve performance exhaust option**

Borla Performance Industries recommends that an exhaust shop or professional after market parts installer, who has all the necessary equipment, tools and experienced personnel needed for proper installation, should perform the installation of this system. However, if you decide to perform the installation, we recommend someone should help you. Ensure the installer uses all under car safety precautions including eye protection.

*Please take time to read and understand the following...*

By installing your Borla Performance exhaust system, you indicate that you have read this document and you agree with the terms stated below.

It is the responsibility of the purchaser to follow all installation instruction guidelines and safety procedures supplied with your Borla Performance exhaust system.

Borla Performance Industries assumes no responsibility for damages occurring from misuse, abuse, improper installation, improper operation, lack of responsible care, or all previously stated reasons resulting from incompatibility with other manufacturer's products and/or systems.

Included with your Borla Performance exhaust system is a warranty card. Please read it carefully before you begin any work on your

**Minimum Required Tool List:**

**TOOLS:**

1. 3/8" Drive Ratchet
2. 3/8" Drive Extension 3"
3. 15mm Deep Well Socket
4. 13mm Socket
5. Pry Bar

**SHOP SUPPLIES:**

- 1 Spray Lubricant

**Borla Performance - Bill of Materials**

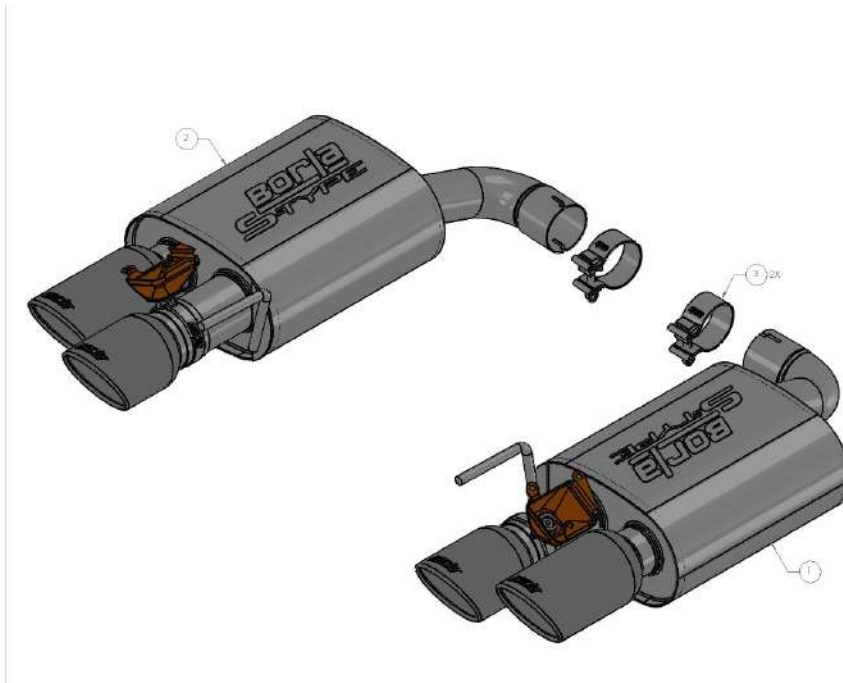

11951

ITEM NO.	QTY.	PART NUMBER	DESCRIPTION
1	1	56806	R/H MUFFLER ASSEMBLY
2	1	56807	L/H MUFFLER ASSEMBLY
3	2	90113	S/S ACCUSEAL CLAMP Ø2.50

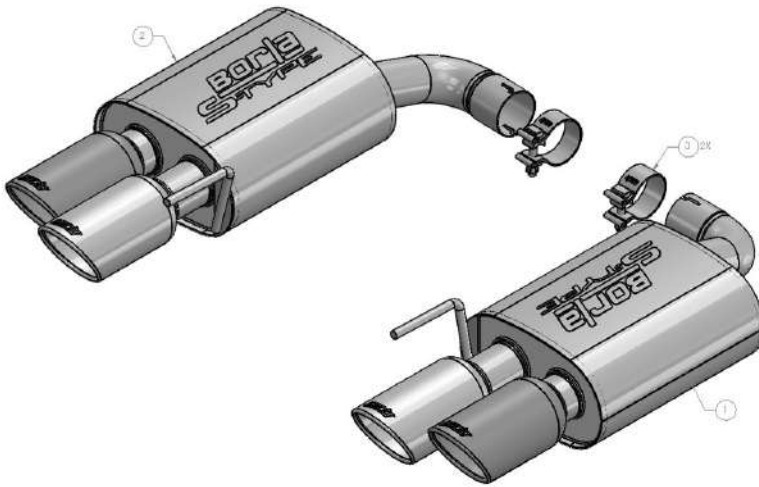

11953

ITEM NO.	QTY.	PART NUMBER	DESCRIPTION
1	1	66813	R/H MUFFLER ASSEMBLY
2	1	66814	L/H MUFFLER ASSEMBLY
3	2	90113	S/S ACORSEAL CLAMP Ø2,50

**Caution!!!** *Never work on a hot exhaust system. Serious injury in the form of burns can result if the vehicle has been in use and the exhaust system is hot, allow vehicle to cool for at least 1 hour. Always wear eye protection when working under any vehicle.*

**Note:** *It is our recommendation that you use a hoist or hydraulic lift to facilitate the installation of your new Borla Performance Exhaust System.*

**Taking all under car safety precautions, lift the vehicle using a hoist or hydraulic lift. Once this has been done, you may begin the removal of your old exhaust system from your vehicle.**

**Note:** *Before removing the original exhaust system from your vehicle, please compare the parts you have received with the bill of materials provided on the previous page to assure that you have all the parts necessary for the installation of your new Borla Performance Exhaust System.*

**Note:** *With a used vehicle, we suggest a penetrating spray lubricant to be applied liberally to all exhaust fasteners and allowing a significant period of time for the chemical to lubricate the threads before attempting to disassemble.*

## Original Exhaust System Removal

1. **Active Valve Performance Exhaust ONLY:** Disconnect wire harness from the electronic actuators from both left and right sides. (See Fig. 1)
2. BEGINNING ON THE RIGHT-SIDE rear muffler, measure and mark a cut-line 2" on the straight section of tube after the bend. (See Fig. 2)
3. Using a metal-cutting bladed saw, cut the pipe at the mark. (See Fig. 3)
4. Remove the Right Side Muffler hanger from the rubber isolator. (See Fig. 4)
5. REPEAT STEPS 1-3 for the LEFT-SIDE REAR MUFFLER removal.
6. Factory exhaust system removed. (See Fig. 5)

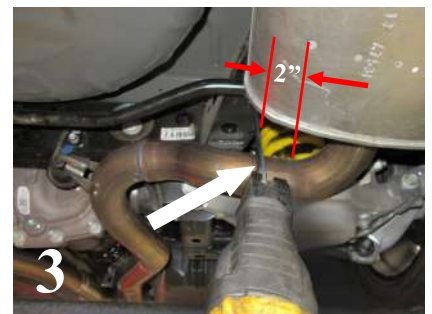

## Borla Performance PN-11951 ONLY Exhaust System Installation (Cont'd)

NOTE: The Actuator Gear on electronic actuator needs to be aligned to the Valve Slot for proper engagement. Improper function of the valves, a CEL, or damage can occur if these aren't aligned.

- A. Valve Plate needs to be in open position (please rotate valve prior to mounting Factory Actuator to **R/H Muffler Assembly**). (See Fig. 10)
- B. Orient the Actuator Gear to the valve Slot then position Factory Actuator bolt holes. Reuse (3) factory bolt/washer/nut assemblies in securing the Factory Actuator to the **Muffler Assembly**. (See Figs. B, C, D)
- C. Verify alignment of Actuator Gear to the valve Slot. Tighten the nut/bolt assemblies 8-9 ft. lb. torque. (See Fig. E)
- D. REPEAT STEPS A, B, & C for the **L/H Muffler Assembly** factory actuator installation.

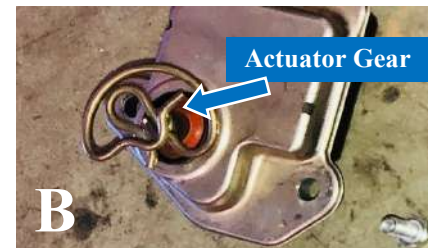
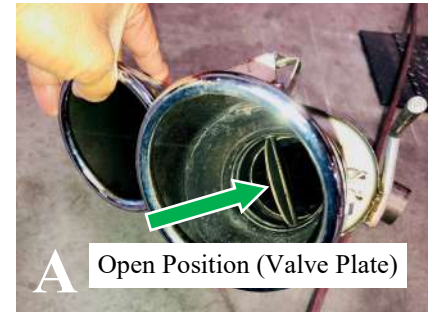

**WARNING:** Use extreme caution during installation. Torque all fasteners according to manufacturer's torque values and tightening sequence. **DO NOT** use air impact tools to tighten fasteners on Borla Performance Exhaust Systems. Use of such tools may result in bent flanges or gasket contact areas leading to exhaust leaks.

NOTE: When you first start your vehicle after the installation of your new Borla Performance Exhaust System, there may be some smoke and fumes coming from the system. This is a protective oil based coating used in the manufacturing of mandrel bent performance exhaust tubing. This is not a problem and will disappear within a very short period of time after the exhaust has reached normal operating temperatures.

## Borla Performance Exhaust System Installation (Cont'd)

7. Starting on the Left-Side, place a clamp on the **L/H Muffler Assembly** inlet pipe and inserting the inlet pipe into the **L/H Intermediate Pipe Assembly**. Insert the hanger into the rear rubber isolator. (See Fig. 6) Do not tighten the clamps.
8. REPEAT STEP 7 for the **R/H Muffler Assembly**. Do not tighten the clamps.
9. **Active Valve Performance Exhaust ONLY: Reconnect Wire Harness to Factory Actuators, both left and right sides.**
10. Check your exhaust system for proper clearance under the vehicle and also for tip alignment. (See Fig. 7)
11. Starting at front flanges and moving to rear of vehicle, tighten flange hardware bolts. Orient position of bolt (on supplied clamps) between (not over) pipe notches and tighten to 35 ft. lbs. torque. (See Fig. 8)
12. Before starting your vehicle, make sure to check all wires, hoses, brake lines, body parts and tires for safe clearance from the exhaust system.
13. Start vehicle and check for any leaks. If any leaks are found, determine cause (such as loose or incorrectly positioned clamp) and repair as necessary.

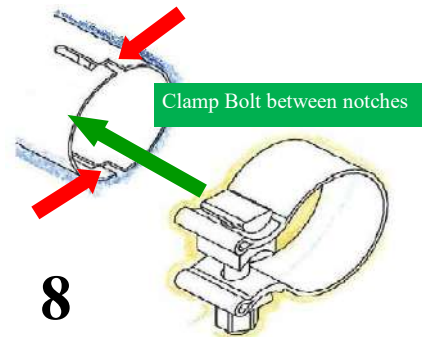

**WARNING:** Use extreme caution during installation. Torque all fasteners according to manufacturer's torque values and tightening sequence. **DO NOT** use air impact tools to tighten fasteners on Borla Performance Exhaust Systems. Use of such tools may result in bent flanges or gasket contact areas leading to exhaust leaks.

**NOTE:** When you first start your vehicle after the installation of your new Borla Performance Exhaust System, there may be some smoke and fumes coming from the system. This is a protective oil based coating used in the manufacturing of mandrel bent performance exhaust tubing. This is not a problem and will disappear within a very short period of time after the exhaust has reached normal operating temperatures.