

## Installation for Honda Accord PN's 11840, 11853, 11949



**\*\*\*\*\* Please compare the parts in the box with the bill of materials provided \*\*\*\*\*  
to assure that you have all the parts necessary for this installation.**

These instructions have been written to help you with the installation of your Borla Performance Exhaust System. Please read this document completely before beginning the installation of your system.

Thank you for purchasing a Borla Performance Rear Section System.

**Borla Performance Rear Section System (PN's 11840, 11853, 11949) are designed for the Honda Accord Sedan, 3.5L 6-cylinder engine, FWD/automatic transmission and Sport Model with 2.4L 4-cylinder engine, FWD/automatic transmission. Does Not fit 2.4L 4-cylinder engine with single exit.**

Borla Performance Industries recommends that an exhaust shop or professional after market parts installer, who has all the necessary equipment, tools and experienced personnel needed for proper installation, should perform the installation of this system. However, if you decide to perform the installation, we recommend someone should help you. Ensure the installer uses all under car safety precautions including eye protection.

*Please take time to read and understand the following...*

By installing your Borla Performance Exhaust System, you indicate that you have read this document and you agree with the terms stated below.

It is the responsibility of the purchaser to follow all installation instruction guidelines and safety procedures supplied with your Borla Performance Exhaust System.

Borla Performance Industries assumes no responsibility for damages occurring from misuse, abuse, improper installation, improper operation, lack of responsible care, or all previously stated reasons resulting from incompatibility with other manufacturer's products and/or systems.

Included with your Borla Performance Exhaust System is a warranty card. Please read it carefully before you begin any work on your vehicle. If you should have any questions regarding our warranty policy, installation, or any other matter pertaining to your new Performance Exhaust System, please give us a call at the number provided on the warranty card.

**Minimum Required Tool List:**

**TOOLS:**

1. 3/8" Drive Ratchet
2. 3/8" Drive Extension 3"
3. 15mm Deep Well Socket
4. 14mm Socket
5. Pry Bar

**SHOP SUPPLIES:**

- 1 Spray Lubricant

**Borla Performance - Bill of Materials**

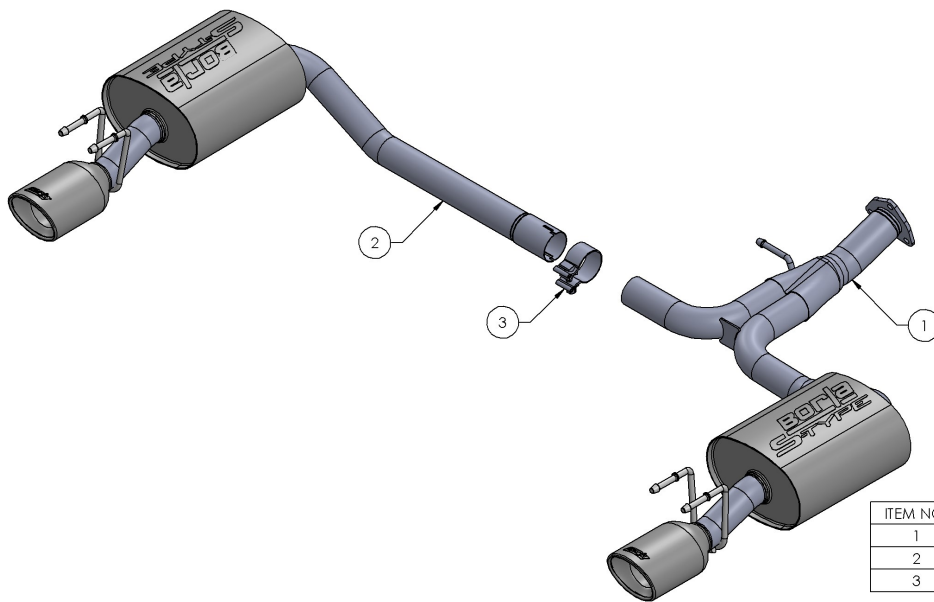

**11840**

ITEM NO.	QTY.	PART NUMBER	DESCRIPTION
1	1	55061	R/H MUFFLER ASSEMBLY
2	1	55062	L/H MUFFLER ASSEMBLY
3	1	90115	S/S ACCUSEAL CLAMP Ø2.00

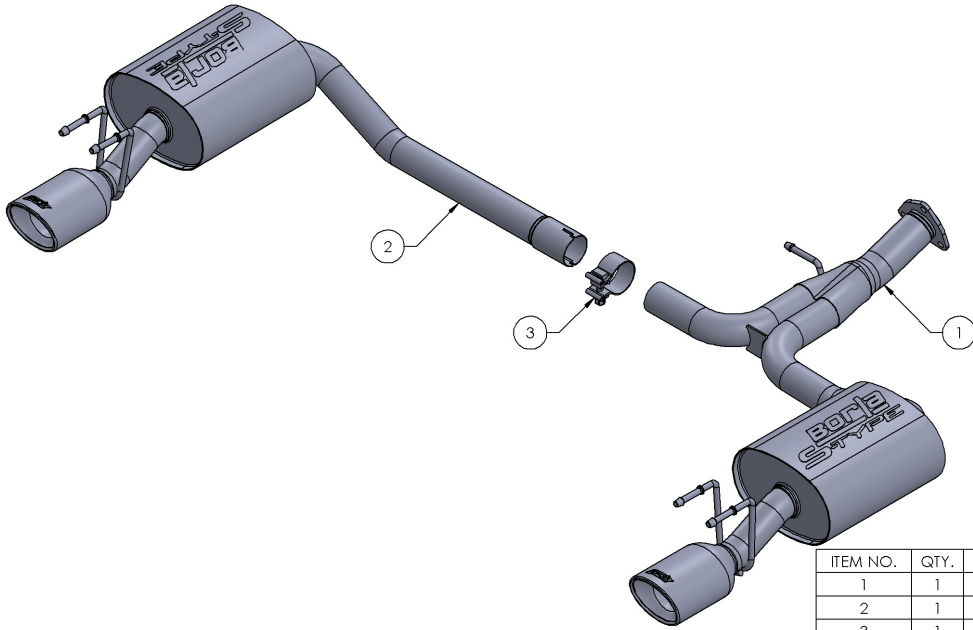

**11853**

ITEM NO.	QTY.	PART NUMBER	DESCRIPTION
1	1	55220	R/H MUFFLER ASSEMBLY
2	1	55221	L/H MUFFLER ASSEMBLY
3	1	90115	S/S ACCUSEAL CLAMP Ø2.00

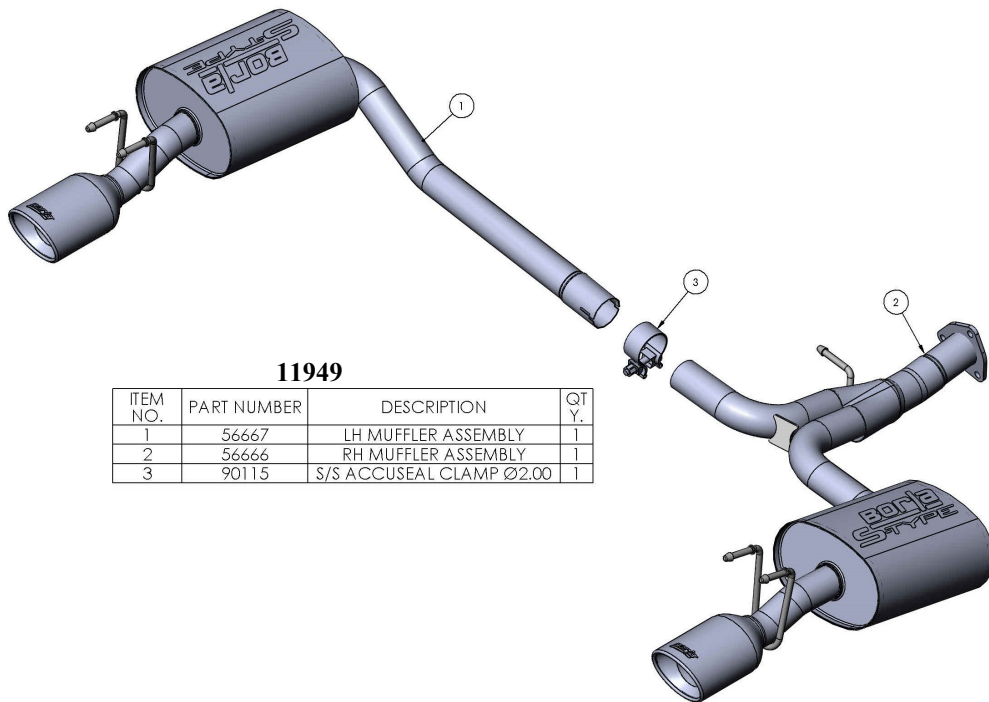

**11949**

ITEM NO.	PART NUMBER	DESCRIPTION	QTY.
1	56667	LH MUFFLER ASSEMBLY	1
2	56666	RH MUFFLER ASSEMBLY	1
3	90115	S/S ACCUSEAL CLAMP Ø2.00	1

**Caution!!!** *Never work on a hot exhaust system. Serious injury in the form of burns can result. If the vehicle has been in use and the exhaust system is hot, allow vehicle to cool for at least 1 hour. Always wear eye protection when working under any vehicle.*

**Note:** *It is our recommendation that you use a hoist or hydraulic lift to facilitate the installation of your new Borla Performance Exhaust System.*

**Taking all under car safety precautions, lift the vehicle using a hoist or hydraulic lift. Once this has been done, you may begin the removal of your old exhaust system from your vehicle.**

**Note:** *Before removing the original exhaust system from your vehicle, please compare the parts you have received with the bill of materials provided on the previous page to assure that you have all the parts necessary for the installation of your new Borla Performance Exhaust System.*

**Note:** *With a used vehicle, we suggest a penetrating spray lubricant to be applied liberally to all exhaust fasteners and allowing a significant period of time for the chemical to lubricate the threads before attempting to disassemble.*

## Original Exhaust System Removal

1. Lubricate all hangers, rubber isolators, bolts and nuts.
2. Remove **Rear Muffler Flange** hardware. Keep factory hardware and sealing gaskets for reinstallation. (See Fig 1)
3. Carefully slide and remove rubber isolators from hangers and remove **Rear Muffler Assembly**. (See Fig. 2 & 3)
4. Original exhaust system removed. (See Fig. 4)
5. Remove factory **Metal Sealing Ring** for reuse and installation on your new exhaust system.

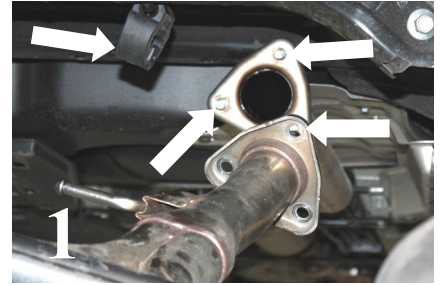

**WARNING:** *Use extreme caution during installation. Torque all fasteners according to manufacturer's torque values and tightening sequence. **DO NOT** use air impact tools to tighten fasteners on Borla Performance Exhaust Systems. Use of such tools may result in bent flanges or gasket contact areas leading to exhaust leaks.*

**NOTE:** *When you first start your vehicle after the installation of your new Borla Performance Exhaust System, there may be some smoke and fumes coming from the system. This is a protective oil based coating used in the manufacturing of mandrel bent performance exhaust tubing. This is not a problem and will disappear within a very short period of time after the exhaust has reached normal operating temperatures.*

## Borla Performance Cat-Back™ Exhaust System Installation

1. Orient components on floor referencing page-2 drawing.
2. Place Muffler Assembly into position using factory gasket. (See Fig. 5)
3. Insert **Right Side Muffler Assembly**, hangers into factory rubber isolators lightly tighten hardware on flange. (See Fig. 6 & 7)
4. Place a clamp over the expanded end of the Y-Pipe insert Left hand Side Muffler Assembly into the Y-Pipe. (See Fig. 8 & 9)
5. Check your exhaust system for proper clearance under the vehicle and also for tip alignment. Starting at front flanges and moving to rear of vehicle, tighten flange hardware bolts. Orient position of bolt (on supplied clamps) between (not over) pipe notches and tighten to 35 ft. lbs. torque. (See Fig. 10)
6. Align tips and tighten hardware. Loosen clamps to rotate or slide pipe for better alignment.
7. Before starting your vehicle, make sure to check all wires, hoses, brake lines, body parts and tires for safe clearance from the exhaust system.
8. Start vehicle and check for any leaks. If any leaks are found, determine cause (such as loose or incorrectly positioned clamp) and repair as necessary.

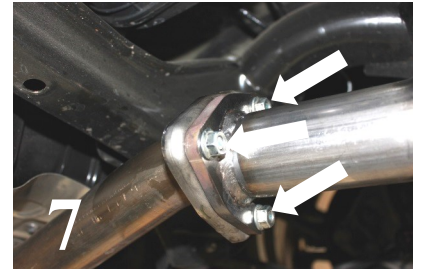

**WARNING:** Use extreme caution during installation. Torque all fasteners according to manufacturer's torque values and tightening sequence. **DO NOT** use air impact tools to tighten fasteners on Borla Performance Exhaust Systems. Use of such tools may result in bent flanges or gasket contact areas leading to exhaust leaks.

**NOTE:** When you first start your vehicle after the installation of your new Borla Performance Exhaust System, there may be some smoke and fumes coming from the system. This is a protective oil based coating used in the manufacturing of mandrel bent performance exhaust tubing. This is not a problem and will disappear within a very short period of time after the exhaust has reached normal operating temperatures.