

Exhaust System Installation for Corvette, C6 or Z06 PN's - 11810, 11811, 11812, 11814, 11815, 11816, 11917



******* Please compare the parts in the box with the bill of materials provided *****
to assure that you have all the parts necessary for this installation.**

These instructions have been written to help you with the installation of your Borla Performance Exhaust System. Please read this document completely before beginning the installation of your system.

Thank you for purchasing a Borla Performance Rear-Section Exhaust System.

Borla Performance exhaust systems (PN's 11810, 11811, 11812, 11814, 11815, 11816) are designed for the Chevrolet Corvette C6 equipped with a 6.2L V-8 engine, automatic or manual transmissions.

Borla Performance exhaust system (PN 11917) is designed for the Chevrolet Corvette C6 Z06 equipped with a 7.0L V-8 engine, manual transmission.

Borla Performance Industries recommends that an exhaust shop or professional after market parts installer, who has all the necessary equipment, tools and experienced personnel needed for proper installation, should perform the installation of this system. However, if you decide to perform the installation, we recommend someone should help you. Ensure the installer uses all under car safety precautions including eye protection.

Please take time to read and understand the following...

By installing your Borla Performance Exhaust System, you indicate that you have read this document and you agree with the terms stated below.

It is the responsibility of the purchaser to follow all installation instruction guidelines and safety procedures supplied with your Borla Performance Exhaust System

Borla Performance Industries assumes no responsibility for damages occurring from misuse, abuse, improper installation, improper operation, lack of responsible care, or all previously stated reasons resulting from incompatibility with other manufacturer's products and/or systems.

Included with your Borla Performance Exhaust System is a warranty card. Please read it carefully before you begin any work on your vehicle. If you should have any questions regarding our warranty policy, installation, or any other matter pertaining to your new Borla Performance Exhaust System, please give us a call at the number provided on the warranty card.

Minimum Required Tool List:

TOOLS:

1. 3/8" Drive Ratchet
2. 3/8" Drive Extension 3"
3. 15mm Deep Well Socket
4. 18mm socket
5. 13mm socket
6. Pry Bar

SHOP SUPPLIES:

- 1 Spray Lubricant

Borla Performance - Bill of Materials

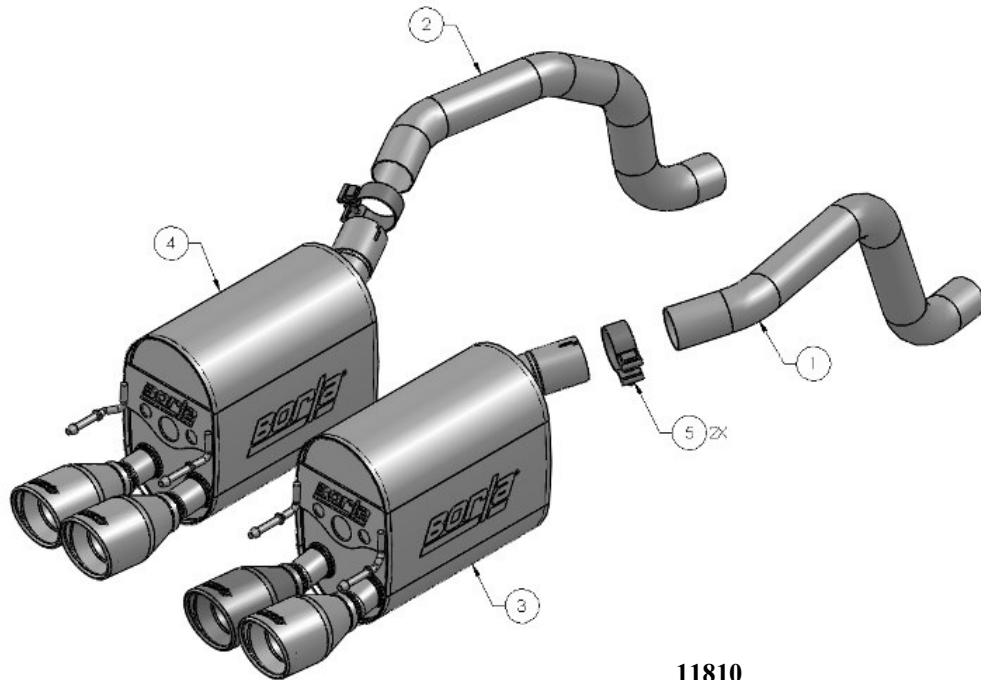

11810

ITEM NO.	QTY.	PART NO.	DESCRIPTION
1	1	67495	R/H OVER-AXLE PIPE: Ø2.50 X 33.00" (FROM 80027)
2	1	67496	L/H OVER-AXLE PIPE: Ø2.50 X 32.35" (FROM 80027)
3	1	54506	R/H MUFFLER ASSEMBLY
4	1	54507	L/H MUFFLER ASSEMBLY
5	2	90113	S/S ACCUSEAL CLAMP Ø2.50

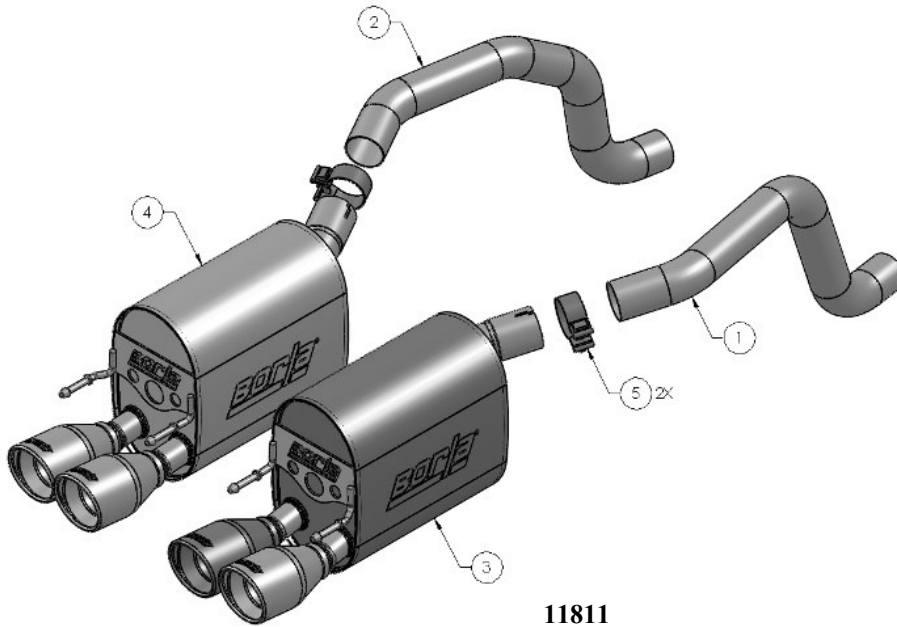

11811

ITEM NO.	QTY.	PART NO.	DESCRIPTION
1	1	67495	R/H OVER-AXLE PIPE: Ø2.50 X 33.00" (FROM 80027)
2	1	67496	L/H OVER-AXLE PIPE: Ø2.50 X 32.35" (FROM 80027)
3	1	54506	R/H MUFFLER ASSEMBLY
4	1	54509	L/H MUFFLER ASSEMBLY
5	2	90113	S/S ACCUSEAL CLAMP Ø2.50

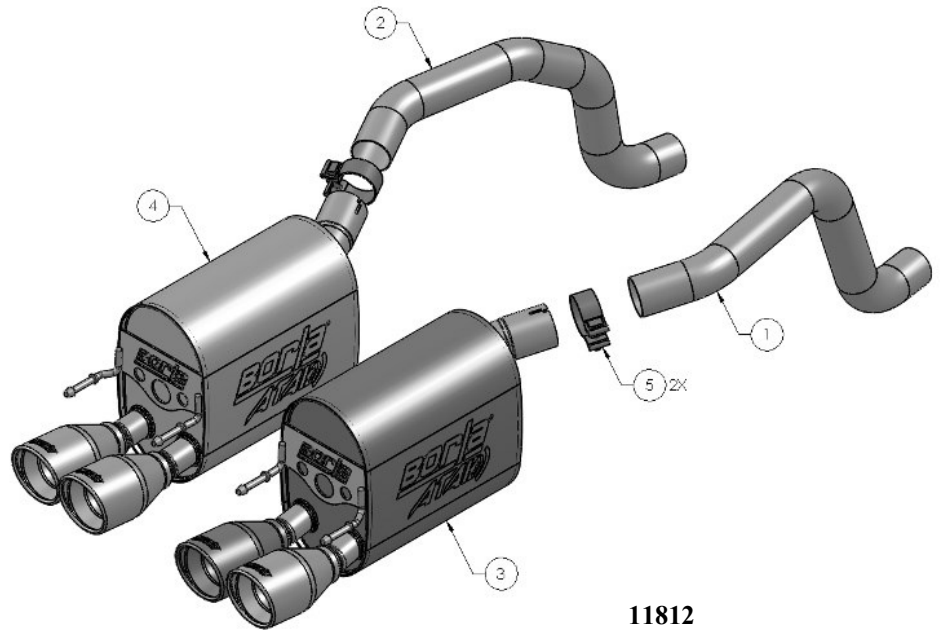

11812

ITEM NO.	QTY.	PART NO.	DESCRIPTION
1	1	67495	R/H OVER-AXLE PIPE: Ø2.50 X 33.00" (FROM 80027)
2	1	67496	L/H OVER-AXLE PIPE: Ø2.50 X 32.35" (FROM 80027)
3	1	54499	R/H MUFFLER ASSEMBLY
4	1	54500	L/H MUFFLER ASSEMBLY
5	2	90113	S/S ACCUSEAL CLAMP Ø2.50

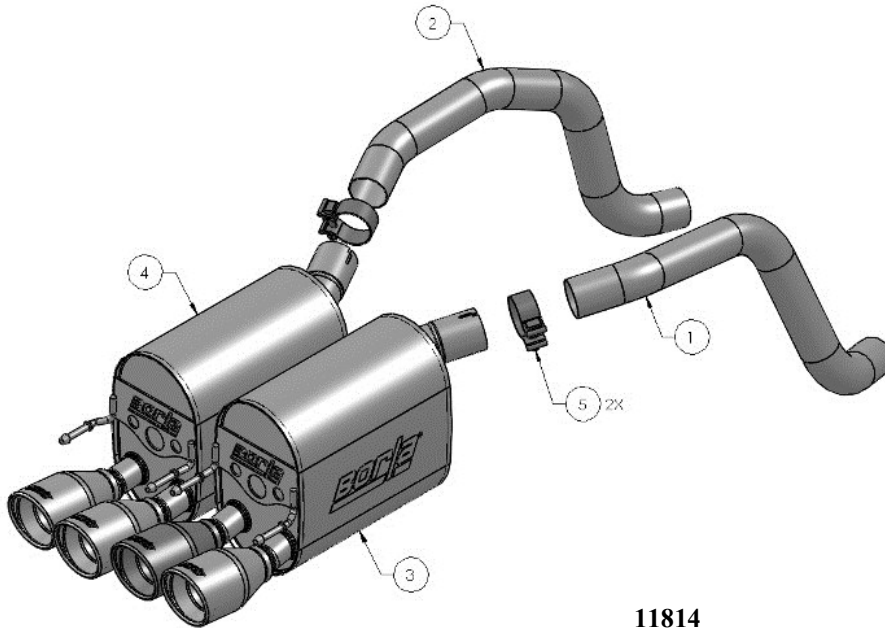

11814

ITEM NO.	QTY.	PART NUMBER	DESCRIPTION
1	1	67620	R/H OVER-AXLE PIPE: Ø2.50 X 32.00"
2	1	67621	L/H OVER-AXLE PIPE: Ø2.50 X 32.75"
3	1	54506	R/H MUFFLER ASSEMBLY
4	1	54507	L/H MUFFLER ASSEMBLY
5	2	90113	S/S ACCUSEAL CLAMP Ø2.50

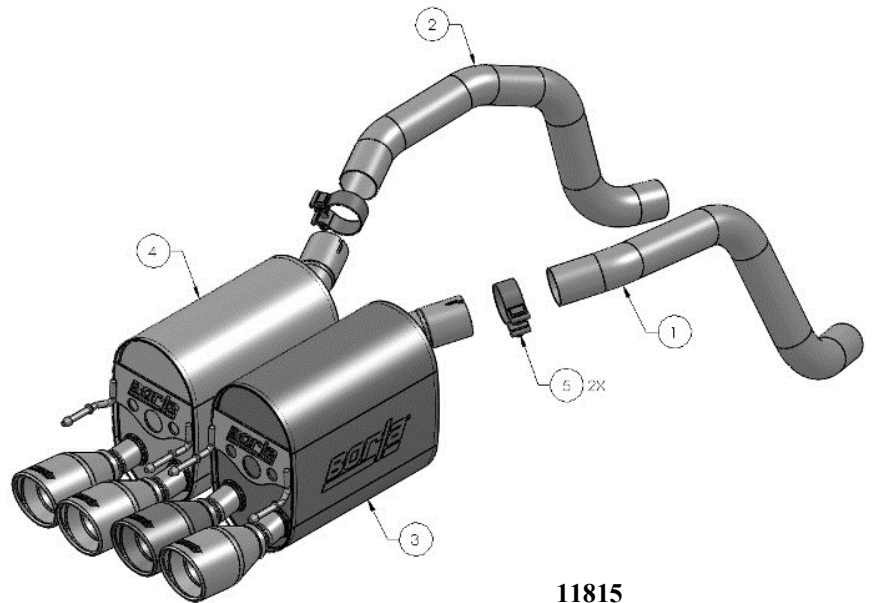

11815

ITEM NO.	QTY.	PART NUMBER	DESCRIPTION
1	1	67620	R/H OVER-AXLE PIPE: Ø2.50 X 32.00"
2	1	67621	L/H OVER-AXLE PIPE: Ø2.50 X 32.75"
3	1	54508	R/H MUFFLER ASSEMBLY
4	1	54509	L/H MUFFLER ASSEMBLY
5	2	90113	S/S ACCUSEAL CLAMP Ø2.50

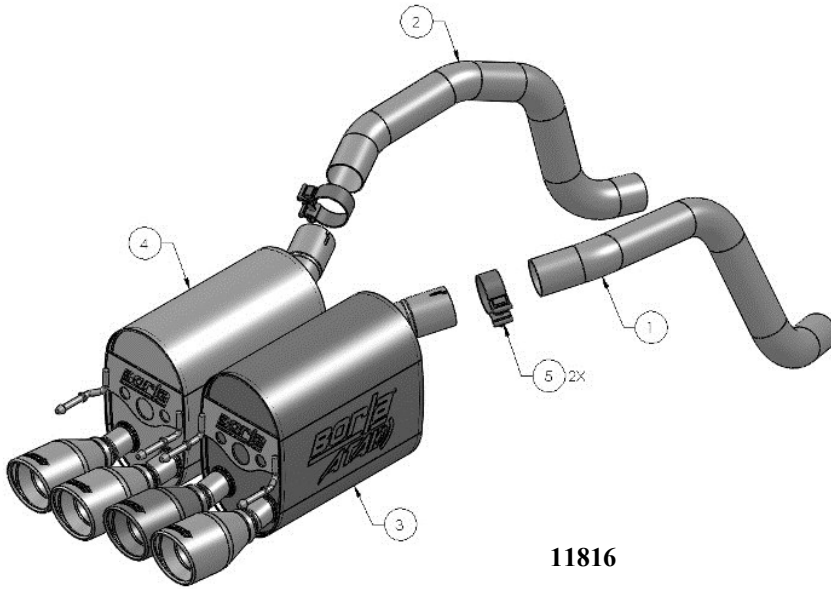

11816

ITEM NO.	QTY.	PART NUMBER	DESCRIPTION
1	1	67620	R/H OVER-AXLE PIPE: Ø2.50 X 32.00"
2	1	67621	L/H OVER-AXLE PIPE: Ø2.50 X 32.75"
3	1	54499	R/H MUFFLER ASSEMBLY
4	1	54500	L/H MUFFLER ASSEMBLY
5	2	90113	S/S ACCUSEAL CLAMP Ø2.50

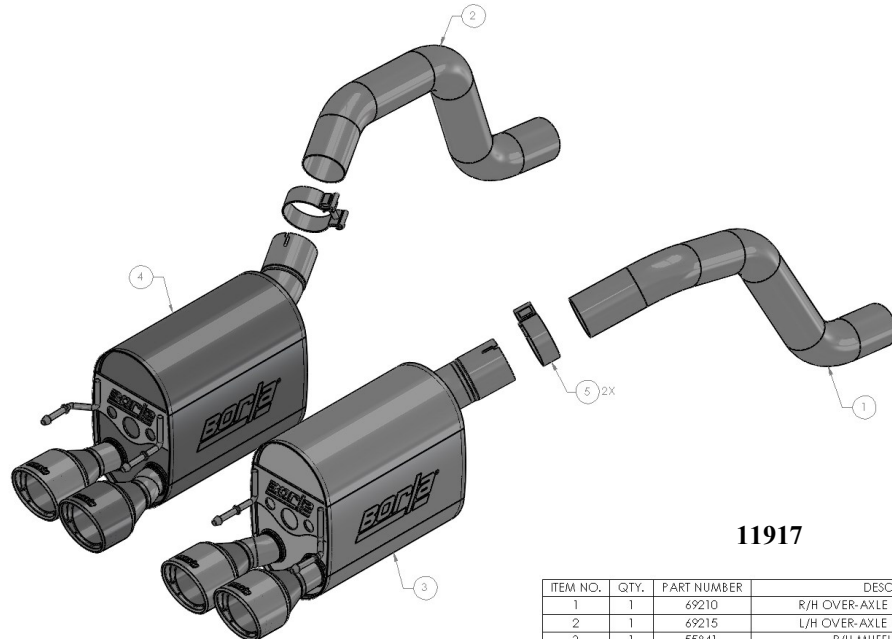

11917

ITEM NO.	QTY.	PART NUMBER	DESCRIPTION
1	1	69210	R/H OVER-AXLE PIPE: Ø3.00 X 33.65"
2	1	69215	L/H OVER-AXLE PIPE: Ø3.00 X 34.45"
3	1	55841	R/H MUFFLER ASSEMBLY
4	1	55842	L/H MUFFLER ASSEMBLY
5	2	90114	3.00 ACCUSEAL CLAMP

Caution!!! *Never work on a hot exhaust system. Serious injury in the form of burns can result if the vehicle has been in use and the exhaust system is hot, allow vehicle to cool for at least 1 hour. Always wear eye protection when working under any vehicle.*

Note: *It is our recommendation that you use a hoist or hydraulic lift to facilitate the installation of your new Borla Performance Exhaust System.*

Taking all under car safety precautions, lift the vehicle using a hoist or hydraulic lift. Once this has been done, you may begin the removal of your old exhaust system from your vehicle.

Note: *Before removing the original exhaust system from your vehicle, please compare the parts you have received with the bill of materials provided on the previous page to assure that you have all the parts necessary for the installation of your new Borla Performance Exhaust System.*

Note: *With a used vehicle, we suggest a penetrating spray lubricant to be applied liberally to all exhaust fasteners and allowing a significant period of time for the chemical to lubricate the threads before attempting to disassemble.*

Original Exhaust System Removal

1. Lubricate all hangers, rubber isolators, bolts and nuts.
2. Loosen the clamps located just under the transmission at the rear of the vehicle, unbolt the spring hanger located just in front of the clamps place bolts to the side for re-installation. (See Fig. 2)
3. Using a muffler stand or an additional person to hold the h-pipe assembly up into position, unbolt the flange located just behind the catalytic converters, place hardware and gaskets to the side for use during re-installation. (See Fig. 3)
4. Remove the vacuum lines from each muffler assembly and insert the plugs included with your new system into each line. Tuck the vacuum lines away into bumper. (See Fig. 4 & 5)
5. Carefully remove the mufflers from the vehicle.

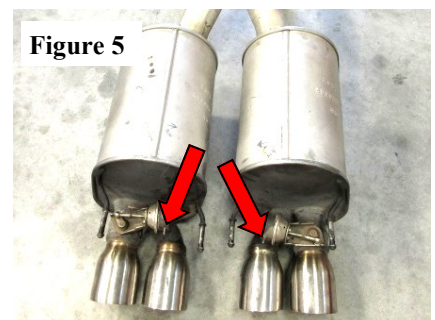
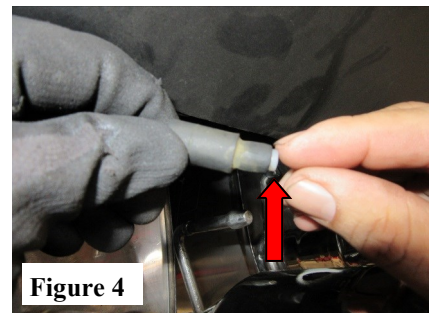
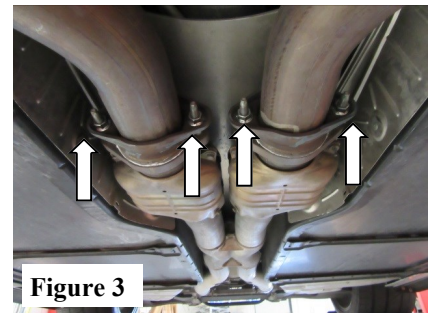
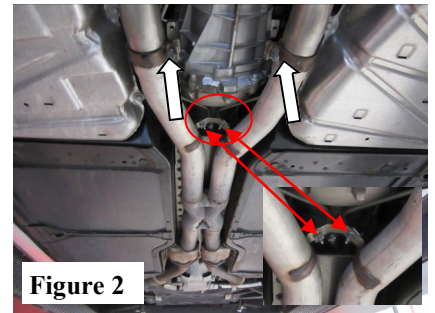
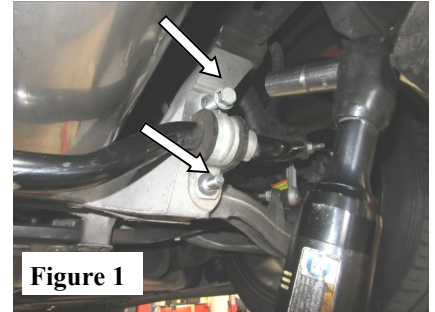

WARNING: *Use extreme caution during installation. Torque all fasteners according to manufacturer's torque values and tightening sequence. **DO NOT** use air impact tools to tighten fasteners on Borla Performance Exhaust Systems. Use of such tools may result in bent flanges or gasket contact areas leading to exhaust leaks.*

NOTE: *When you first start your vehicle after the installation of your new Borla Performance Exhaust System, there may be some smoke and fumes coming from the system. This is a protective oil based coating used in the manufacturing of mandrel bent performance exhaust tubing. This is not a problem and will disappear within a very short period of time after the exhaust has reached normal operating temperatures.*

Borla Performance Exhaust System Installation

1. Re-install the H-pipe assembly in the opposite order of removal and using the original hardware, reinstall the spring hanger. Hand tighten the flange for now. (See Fig. 6)
2. Place a clamp over the expanded end of **R/H Over-Axle Pipe** and install to **R/H Rear Muffler Assembly** inlet. (See Fig. 7) **DO NOT TIGHTEN HARDWARE.**
3. Repeat step 2 for the **L/H Over-Axle Pipe** to **L/H Rear Mufflers**.
4. Insert right-side rear assembly over rear-axle and insert inlet to installed H-Pipe. Carefully insert hangers into rubber isolator. (See Fig. 8) **DO NOT TIGHTEN HARDWARE.**
5. Repeat step 4 for the left-side rear assembly. (See Fig. 8)
6. Swing the anti-sway bar back into position re-install the original hardware previously removed. Torque the upper bolts to 45-49ft. Lbs. and the lower nuts to 65-70 ft. lbs. (See Fig. 9)
7. Check your exhaust system for proper clearance under the vehicle and also for tip alignment. (See Fig. 10)
8. Once position has been determined to be correct, tighten the Accuseal clamps to 32-35 ft. lbs.
9. Before starting your vehicle, make sure to check all wires, hoses, brake lines, body parts and tires for safe clearance from the exhaust system.
10. Start vehicle and check for any leaks. If any leaks are found, determine cause (such as loose or incorrectly positioned clamp) and repair as necessary.

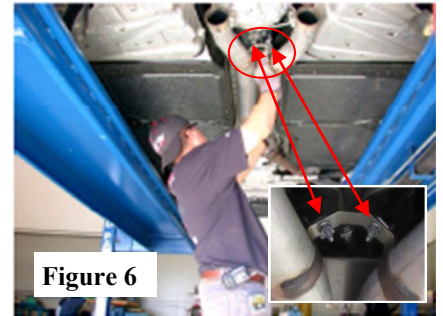

Figure 6

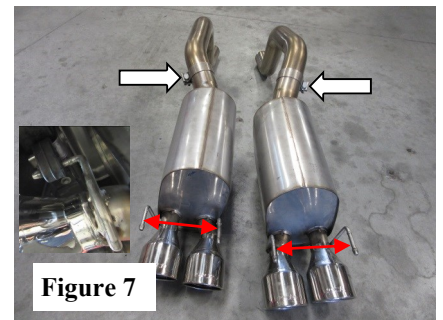

Figure 7

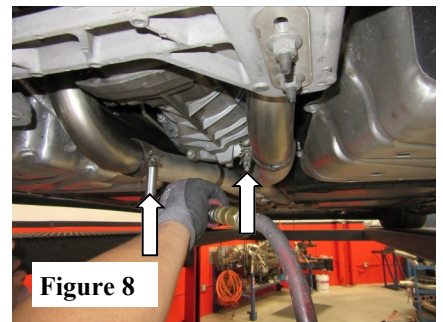

Figure 8

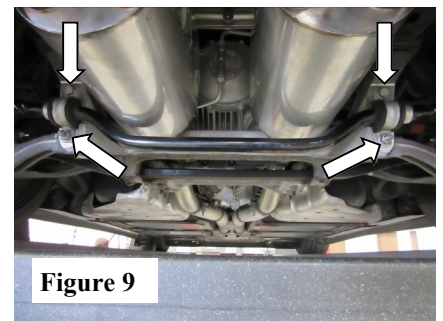

Figure 9



Figure 10

WARNING: Use extreme caution during installation. Torque all fasteners according to manufacturer's torque values and tightening sequence. **DO NOT** use air impact tools to tighten fasteners on Borla Performance Exhaust Systems. Use of such tools may result in bent flanges or gasket contact areas leading to exhaust leaks.

NOTE: When you first start your vehicle after the installation of your new Borla Performance Exhaust System, there may be some smoke and fumes coming from the system. This is a protective oil based coating used in the manufacturing of mandrel bent performance exhaust tubing. This is not a problem and will disappear within a very short period of time after the exhaust has reached normal operating temperatures.