

Chevrolet Camaro Exhaust System Installation PN-140330/140331/140378



Thank you for purchasing a Borla Performance Cat-Back™ Exhaust System.

This Borla Performance Cat-back™ Exhaust System (Part number 140330, 140331, 140378) is designed for Chevrolet Camaro with rear OE ground-effects option, equipped with a 6.2L V-8 engine and automatic or manual transmissions.

Borla Performance Industries recommends that an exhaust shop or professional after market parts installer perform the installation of this system. However, if you decide to perform the installation on your own it is recommended that two people are used. This installation should not be performed by one person due to the risk of injury. Ensure the installers use all under car safety precautions including eye protection.

Please take time to read and understand the following...

By installing your Borla Performance Exhaust System, you indicate that you have read this document and you agree with the terms stated below.

It is the responsibility of the purchaser to follow all installation instruction guidelines and safety procedures supplied with your Borla Performance Exhaust System

Borla Performance Industries assumes no responsibility for damages occurring from misuse, abuse, improper installation, improper operation, lack of responsible care, or all previously stated reasons resulting from incompatibility with other manufacturer's products and/or systems.

Minimum Required Tool List:**TOOLS:**

- 1 3/8" Drive Ratchet
- 2 3/8" Drive Extension 3"
- 3 15mm Socket
- 4 Pry Bar

SHOP SUPPLIES:

- 1 Spray Lubricant

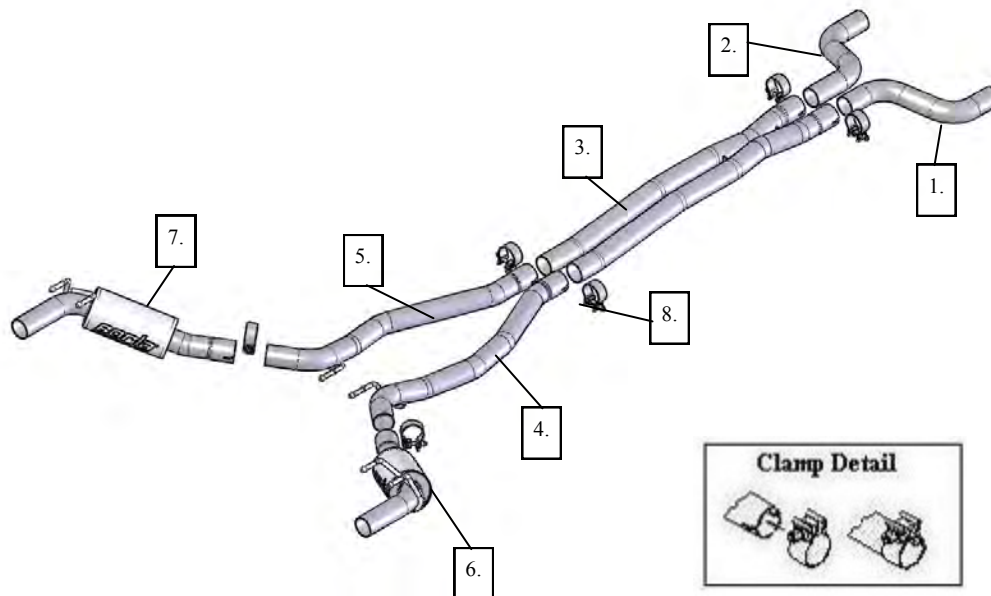
Borla Performance Cat-Back™ Bill of Materials

1. R/H Front Pipe
2. L/H Front Pipe
3. X-Pipe Assembly
4. R/H Intermediate Pipe Assm
5. L/H Intermediate Pipe Assm
6. R/H Rear Muffler Assm
7. L/H Rear Muffler Assm
8. 2.50" Accuseal Clamps (qty 6)

Caution!!! Never work on a hot exhaust system. Serious injury in the form of burns can result If the vehicle has been in use and the exhaust system is hot, allow vehicle to cool for at least 1 hour. Always wear eye protection when working under any vehicle.

Note: It is our recommendation that you use a hoist or hydraulic lift to facilitate the installation of your new Borla Performance Cat-Back™ Exhaust System.

Taking all under car safety precautions, lift the vehicle using a hoist or hydraulic lift. Once this has been done, you may begin the removal of your old exhaust system from your vehicle.

Note: Before removing the original exhaust system from your vehicle, please compare the parts you have received with the bill of materials provided on the previous page to assure that you have all the parts necessary for the installation of your new Borla Performance Cat-Back™ Exhaust System.

Original Exhaust System Removal

Note: With a used vehicle, we suggest a penetrating spray lubricant to be applied liberally to all exhaust fasteners and allowing a significant period of time for the chemical to lubricate the threads before attempting to disassemble.

1. On each exhaust pipe behind the catalytic converter, unbolt the clamp (figure 1) using a 15mm socket. Unbend the metal tab (figure 2) on each pipe.
2. Remove (4) cross-brace support bolts using 15mm socket (figure 3). Place hardware to the side.
3. Lubricate all the hangers and rubber isolators.
4. Using a muffler stand or an additional person to hold the rear muffler into position, remove the hangers from the rubber isolators (figure 4) and at each rear muffler.
5. Supporting the front exhaust assembly, remove front section pipes and carefully slide assembly forward removing tips from valence and carefully remove exhaust assembly from the vehicle as shown.

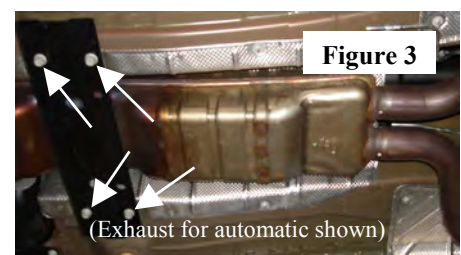
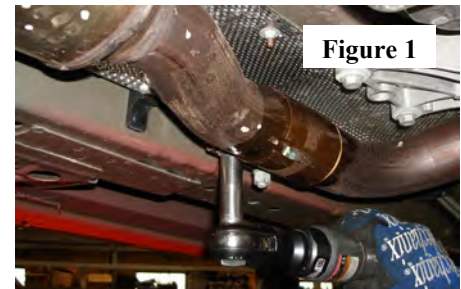

Warning: Use extreme caution during installation. Torque all fasteners according to manufacturer's torque values and tightening sequence. DO NOT use air impact tools to tighten fasteners on Borla Performance Exhaust Systems. Use of such tools may result in bent flanges or gasket contact areas leading to exhaust leaks.

Borla Performance Cat-Back™ Exhaust System Installation

1. Place removed OE exhaust system on the ground and using this as a reference, arrange components of new exhaust (figure 5).
2. Place a clamp over the expanded end of the R/H Front Pipe and fit on right-side exhaust. Place a clamp over end of X-Pipe Assembly and fit into R/H Front Pipe (figure 6) . Verify orientation of X-Pipe Assembly with curvature as shown (figure 7). Do Not tighten the clamps. Repeat for L/H Front Pipe.
3. Place a clamp over the expanded end of R/H Intermediate Pipe Assembly and set it into position as shown in figure 6 making sure to install the hangers into the rubber isolators. Do Not tighten the clamp. Repeat for L/H Intermediate Pipe Assembly.
4. Install OE crossbrace support using original hardware. (figure 8)
5. Assemble R/H Rear Muffler Assembly making sure to install the hangers into the rubber isolators (figure 9) and at mufflers. Repeat for the L/H Rear Muffler Assembly. *Check your exhaust system for proper clearance under the vehicle and also for tip alignment.* (figure 10)
4. Once position has been determined to be correct, tighten the Accuseal™ clamp to 32-35 ft. lbs. making sure the clamps openings are not over any of the notches in the pipes.
5. Before starting your vehicle, make sure to check all wires, hoses, brake lines, body parts and tires for safe clearance from the exhaust system.
6. Start vehicle and check for any leaks. If any leaks are found, determine cause (such as loose hardware or incorrectly positioned clamp) and repair as necessary.

Note: When you first start your vehicle after the installation of your new Borla Performance Exhaust System, there may be some smoke and fumes coming from the system. This is a protective oil based coating used in the manufacturing of mandrel bent performance exhaust tubing. This is not a problem and will disappear within a very short period of time after the exhaust has reached normal operating temperatures.

