

Exhaust System Installation For MINI Countryman



Thank you for purchasing a Borla Performance Exhaust System.

Borla Performance Rear Section Exhaust System (part number 11804) is designed for Mini Countryman w/ 1.6L 4-cylinder turbo engine and automatic or manual transmission.

Borla Performance Industries recommends that an exhaust shop or professional after market parts installer perform the installation of this system. However, if you decide to perform the installation on your own it is recommended that two people are used. This installation should not be performed by one person due to the risk of injury. Ensure the installers use all under car safety precautions including eye protection.

Please take time to read and understand the following...

By installing your Borla Performance Exhaust System, you indicate that you have read this document and you agree with the terms stated below.

It is the responsibility of the purchaser to follow all installation instruction guidelines and safety procedures supplied with your Borla Performance Exhaust System

Borla Performance Industries assumes no responsibility for damages occurring from misuse, abuse, improper installation, improper operation, lack of responsible care, or all previously stated reasons resulting from incompatibility with other manufacturer's products and/or systems.

Minimum Required Tool List:

TOOLS:

1. 3/8” Drive Ratchet
2. 3/8” Drive Extension 3”
3. 15mm Deep Well Socket
4. Pry Bar
5. Metal cutting blade saw

SHOP SUPPLIES:

- 1 Spray Lubricant

Borla Performance - Bill of Materials

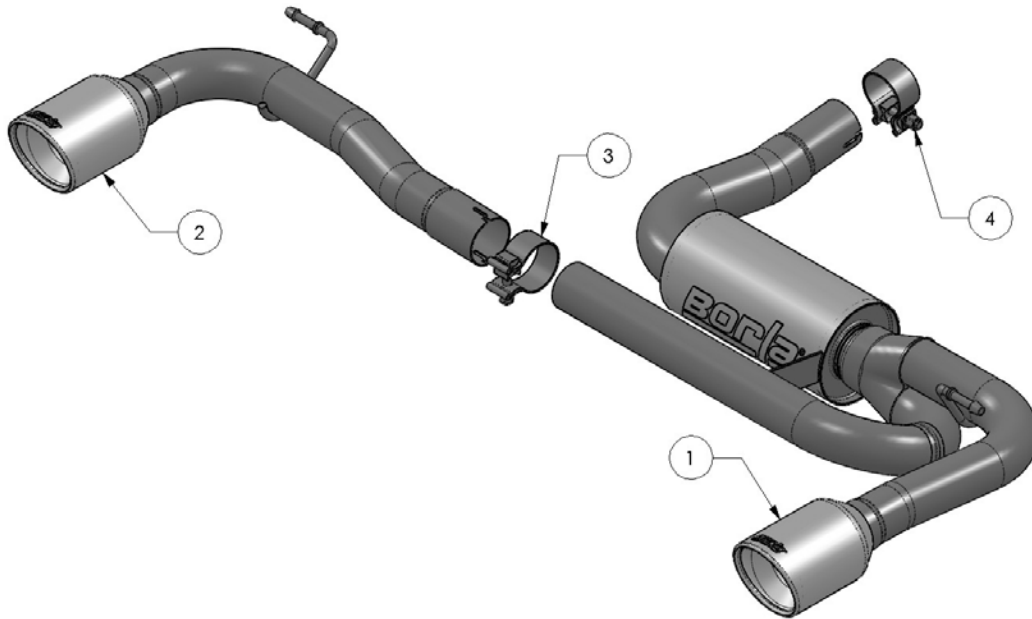

ITEM NO.	QTY.	PART NO.	DESCRIPTION
1	1	54483	MUFFLER ASSEMBLY
2	1	54484	TAIL PIPE ASSEMBLY
3	1	90112	S/S ACCUSEAL CLAMP \varnothing 2.25
4	1	90124	S/S ACCUSEAL CLAMP: \varnothing 2.125

Caution!!! *Never work on a hot exhaust system. Serious injury in the form of burns can result* If the vehicle has been in use and the exhaust system is hot, allow vehicle to cool for at least 1 hour. Always wear eye protection when working under any vehicle.

Note: It is our recommendation that you use a hoist or hydraulic lift to facilitate the installation of your new Borla Performance Rear Section Exhaust System.

Taking all under car safety precautions, lift the vehicle using a hoist or hydraulic lift. Once this has been done, you may begin the removal of your old exhaust system from your vehicle.

Note: Before removing the original exhaust system from your vehicle, please compare the parts you have received with the bill of materials provided on the previous page to assure that you have all the parts necessary for the installation of your new Borla Performance Rear Section Exhaust System.

Original Exhaust System Removal

Note: With a used vehicle, we suggest a penetrating spray lubricant to be applied liberally to all exhaust fasteners and allowing a significant period of time for the chemical to lubricate the threads before attempting to disassemble.

1. Lubricate all the hangers and rubber isolators. Place all hardware to the side for installation of your new Borla exhaust.
2. Measure and mark a cut-line 11" on stock muffler pipe. Using a metal-cutting saw, carefully cut pipe making sure not to damage underside of vehicle. Clean cut pipe with file. (See Fig.1A, 1B)
3. Slide and remove rubber isolators from hangars and remove rear muffler. (See Figs.2 & 3)

Warning: Use extreme caution during installation. Torque all fasteners according to manufacturer's torque values and tightening sequence. **DO NOT** use air impact tools to tighten fasteners on Borla Performance Exhaust Systems. Use of such tools may result in bent flanges or gasket contact areas leading to exhaust leaks.

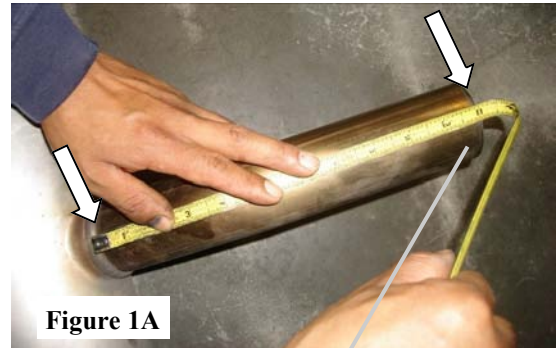

Figure 1A

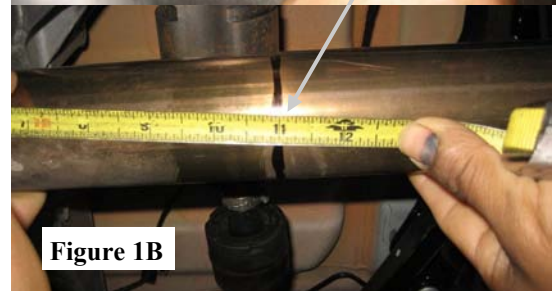

Figure 1B



Figure 2



Figure 3

Borla Performance Rear Section Exhaust System Installation

1. Place provided clamp over Muffler Assembly inlet pipe and slip over newly cut pipe and install Tail Pipe Assembly into rubber isolators. Don't tighten clamp. (See Fig.4)
2. Place provided clamp over Muffler Assembly outlet pipe. Slip Tail Pipe Assembly over this outlet pipe and insert hangers into rubber isolators. **DO NOT TIGHTEN CLAMP.** (See Fig.5)
3. Check your exhaust for proper clearance under the vehicle and for tip alignment. (See Fig. 6)
4. Position clamp with bolt between pipe notches and hand-torque to 35 ft. lbs. torque. (See Fig.7)
5. Start vehicle and check for any leaks. If any leaks are found, determine cause (such as loose hardware or incorrectly positioned clamp) and repair as necessary.

Note: When you first start your vehicle after the installation of your new Borla Performance Exhaust System, there may be some smoke and fumes coming from the system. This is a protective oil based coating used in the manufacturing of mandrel bent performance exhaust tubing. This is not a problem and will disappear within a very short period of time after the exhaust has reached normal operating temperatures.

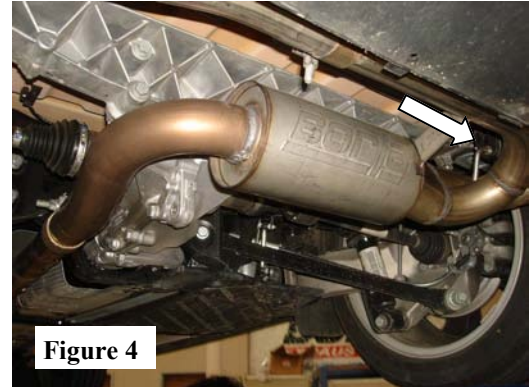

Figure 4

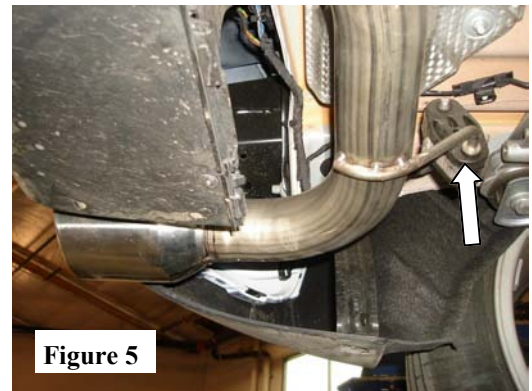

Figure 5

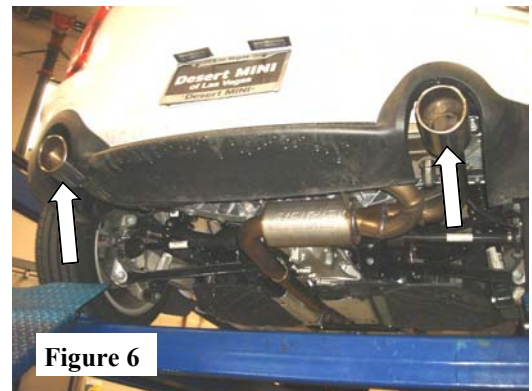

Figure 6

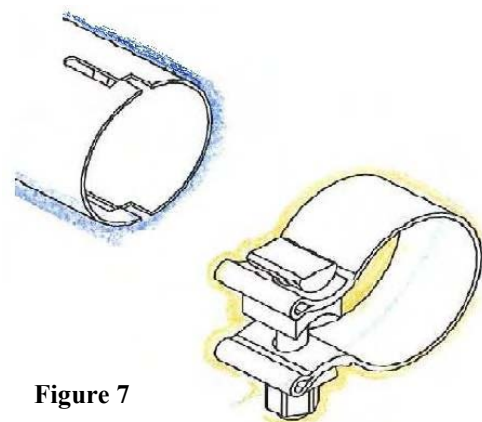

Figure 7