

Chevrolet Camaro

Rear-Section Exhaust System Installation

PN-11774, 11775, 11776, 11788, 11800, 11801, & 11794



Thank you for purchasing a Borla Performance Exhaust System.

These Borla Performance Exhaust Systems (part number 11774, 11775, 11788, 11800, 11801, & 11794) are designed for the Chevrolet Camaro equipped with a 6.2L V-8 engine with an automatic or manual transmissions.

Borla Performance Exhaust System (part number 11776) is designed for the Chevrolet Camaro equipped with a 3.6L V-6 engine with an automatic or manual transmission.

Borla Performance Industries recommends that an exhaust shop or professional after market parts installer perform the installation of this system. However, if you decide to perform the installation on your own it is recommended that two people are used. This installation should not be performed by one person due to the risk of injury. Ensure the installers use all under car safety precautions including eye protection.

Please take time to read and understand the following...

By installing your Borla Performance Exhaust System, you indicate that you have read this document and you agree with the terms stated below.

It is the responsibility of the purchaser to follow all installation instruction guidelines and safety procedures supplied with your Borla Performance Exhaust System

Borla Performance Industries assumes no responsibility for damages occurring from misuse, abuse, improper installation, improper operation, lack of responsible care, or all previously stated reasons resulting from incompatibility with other manufacturer's products and/or systems.

Minimum Required Tool List:

TOOLS:

- 1 3/8" Drive Ratchet
- 2 3/8" Drive Extension 3"
- 3 15mm Deep Well Socket

SHOP SUPPLIES:

- 1 Spray Lubricant

Borla Performance Rear-Section - Bill of Materials

- 1. R/H Rear Muffler Assembly
- 2. L/H Rear Muffler Assembly
- 3. Accuseal Clamps (qty 2)

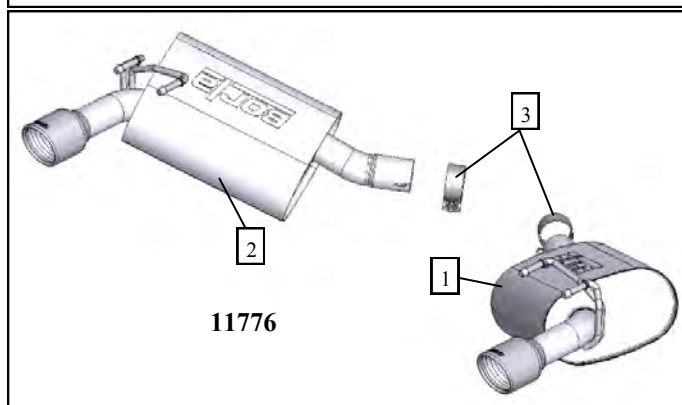
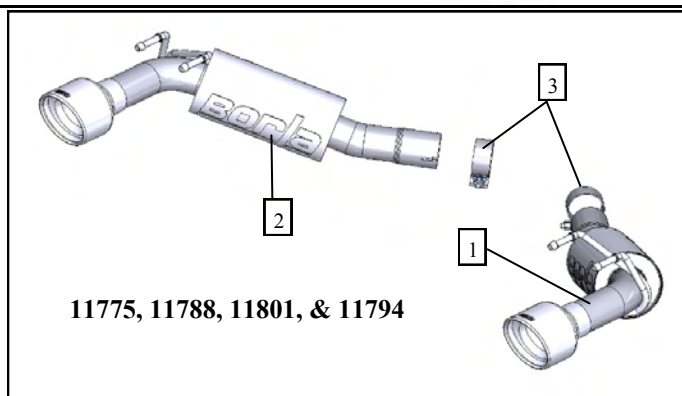
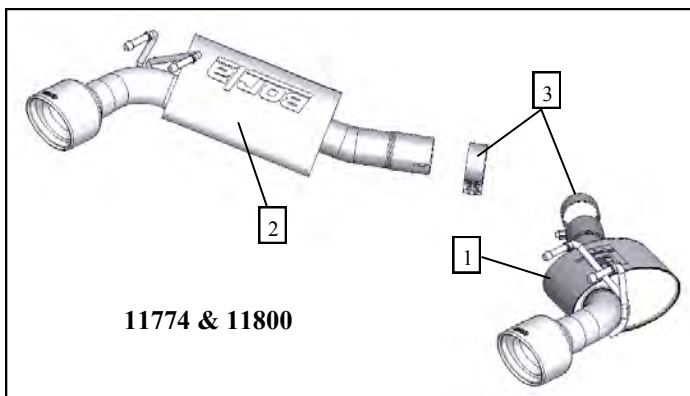
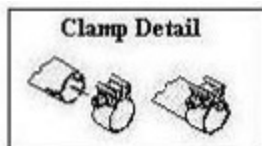

NOTE: 11800, 11801, & 11794 are designed for the Camaro with optional Ground Effects kit and does not include polished tips as shown.

Caution!!! Never work on a hot exhaust system. Serious injury in the form of burns can result If the vehicle has been in use and the exhaust system is hot, allow vehicle to cool for at least 1 hour. Always wear eye protection when working under any vehicle.

Note: It is our recommendation that you use a hoist or hydraulic lift to facilitate the installation of your new Borla Performance Rear Section Exhaust System.

Taking all under car safety precautions, lift the vehicle using a hoist or hydraulic lift. Once this has been done, you may begin the removal of your old exhaust system from your vehicle.

Note: Before removing the original exhaust system from your vehicle, please compare the parts you have received with the bill of materials provided on the previous page to assure that you have all the parts necessary for the installation of your new Borla Performance Rear Section Exhaust System.

Original Exhaust System Removal & Installation

Note: With a used vehicle, we suggest a penetrating spray lubricant to be applied liberally to all exhaust fasteners and allowing a significant period of time for the chemical to lubricate the threads before attempting to disassemble.

1. From under the vehicle use a measuring tape to measure from the muffler box seam back along the axis of the muffler inlet pipe 59mm (2.32") and mark the point on the exhaust pipe. (see figure 1)

Note: This cut position is the same on both LH & RH side Exhaust Pipes.

2. Confirm the mark is in the correct location and cut the pipe along the marked cut line.
3. Remove the muffler from its rubber hangers and discard the old muffler. De-burr the end of the exhaust pipe. (See Fig.2)
4. Slide the exhaust clamp onto the new exhaust pipe. Install the replacement muffler onto the rubber exhaust hangers and slide the muffler onto the exhaust pipe. (See Fig. 3)
5. Position tip in rear valence and tighten the clamp bolt to 32-35 ft.lbs. torque. (See Fig. 4)
6. Repeat instructions for the opposite side.

NOTE: 11800 & 11801 are designed for the Camaro 6.2L with optional Ground Effects kit and does not included polished tips as shown.

Warning: Use extreme caution during installation. Torque all fasteners according to manufacturer's torque values and tightening sequence. DO NOT use air impact tools to tighten fasteners on Borla Performance Exhaust Systems. Use of such tools may result in bent flanges or gasket contact areas leading to exhaust leaks.

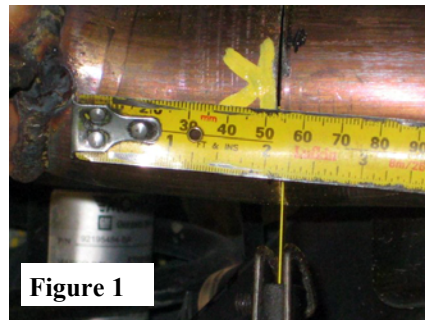

Figure 1



Figure 2



Figure 3

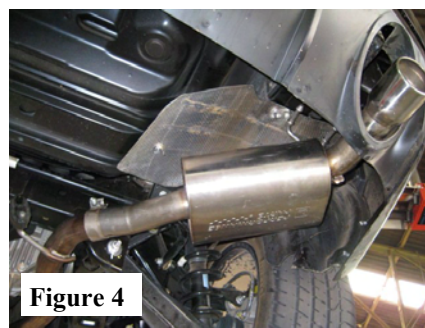

Figure 4