

Exhaust System Installation
Ford Mustang V6 & Mustang GT
PN- 11789, 11790, 11791, 11792, & 11793



Thank you for purchasing a Borla Performance Rear Section Exhaust System.

Borla Performance Rear Section Exhaust System (PN- 11789, 11790, 11791) have been designed for Ford Mustang GT equipped with a 5.0L V-8 engine/automatic or manual transmissions.

Borla Performance Rear Section Exhaust System (PN-11792, 11793) have been designed for the Mustang V6 with a 3.7L engine/automatic or manual transmissions.

Borla Performance Industries recommends that an exhaust shop or professional after market parts installer perform the installation of this system. However, if you decide to perform the installation on your own it is recommended that two people are used. This installation should not be performed by one person due to the risk of injury. Ensure the installers use all under car safety precautions including eye protection.

Please take time to read and understand the following...

By installing your Borla Performance Exhaust System, you indicate that you have read this document and you agree with the terms stated below.

It is the responsibility of the purchaser to follow all installation instruction guidelines and safety procedures supplied with your Borla Performance Exhaust System

Borla Performance Industries assumes no responsibility for damages occurring from misuse, abuse, improper installation, improper operation, lack of responsible care, or all previously stated reasons resulting from incompatibility with other manufacturer's products and/or systems.

Minimum Required Tool List:**TOOLS:**

- 1 3/8" Drive Ratchet
- 2 3/8" Drive Extension 3"
- 3 15mm Socket
- 4 Pry Bar
- 5 Flat blade screwdriver

SHOP SUPPLIES:

- 1 Spray Lubricant

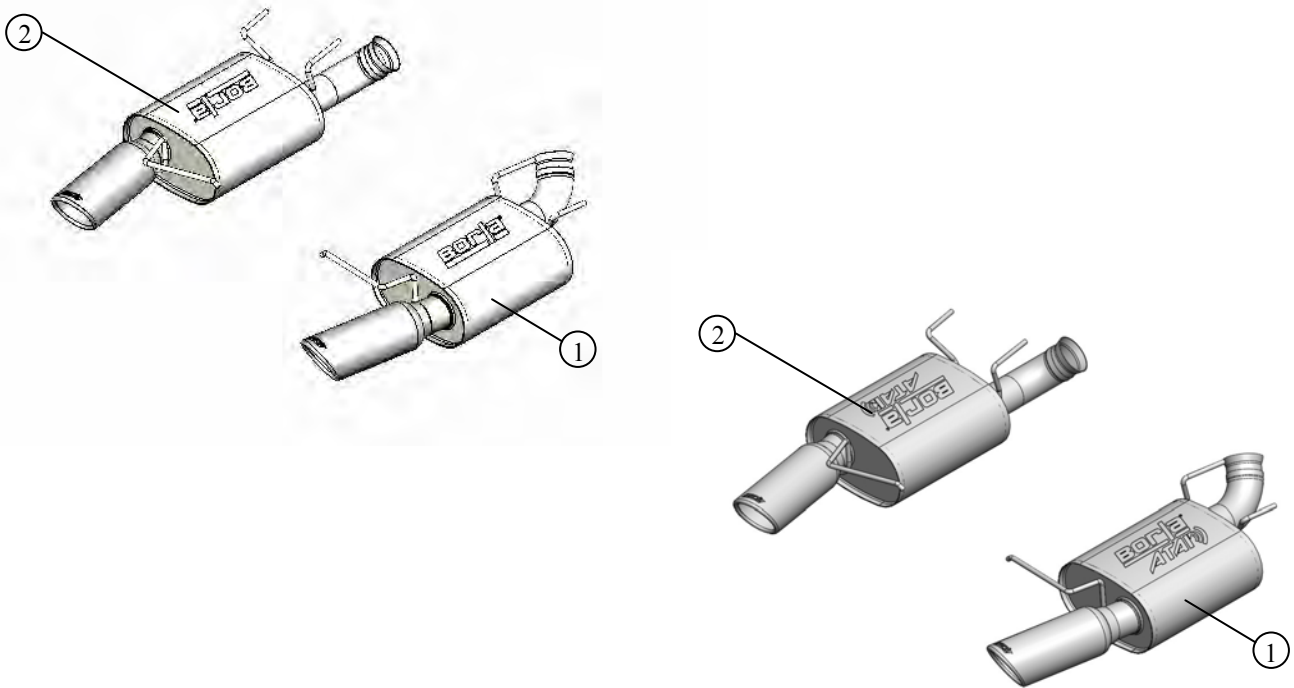
Borla Performance Rear-Section™ Bill of Materials

1. R/H muffler assembly
2. L/H muffler assembly

Caution!!! Never work on a hot exhaust system. Serious injury in the form of burns can result If the vehicle has been in use and the exhaust system is hot, allow vehicle to cool for at least 1 hour. Always wear eye protection when working under any vehicle.

Note: It is our recommendation that you use a hoist or hydraulic lift to facilitate the installation of your new Borla Performance Exhaust System.

Taking all under car safety precautions, lift the vehicle using a hoist or hydraulic lift. Once this has been done, you may begin the removal of your old exhaust system from your vehicle.

Note: Before removing the original exhaust system from your vehicle, please compare the parts you have received with the bill of materials provided on the previous page to assure that you have all the parts necessary for the installation of your new Borla Performance Exhaust System.

Original Exhaust System Removal

Note: With a used vehicle, we suggest a penetrating spray lubricant to be applied liberally to all exhaust fasteners and allowing a significant period of time for the chemical to lubricate the threads before attempting to disassemble.

1. Lubricate hangers and rubber isolators on the rear mufflers.
2. Loosen the passenger side ball-clamp behind the rear axle pipe and carefully remove right-side muffler from hangers. **Do not discard clamps as they will be used for installation of your new exhaust.** (See Fig. 1)
3. Repeat above step for left-side muffler. (See Fig. 2)

Warning: Use extreme caution during installation. Torque all fasteners according to manufacturer's torque values and tightening sequence. DO NOT use air impact tools to tighten fasteners on Borla Performance Exhaust Systems. Use of such tools may result in bent flanges or gasket contact areas leading to exhaust leaks.

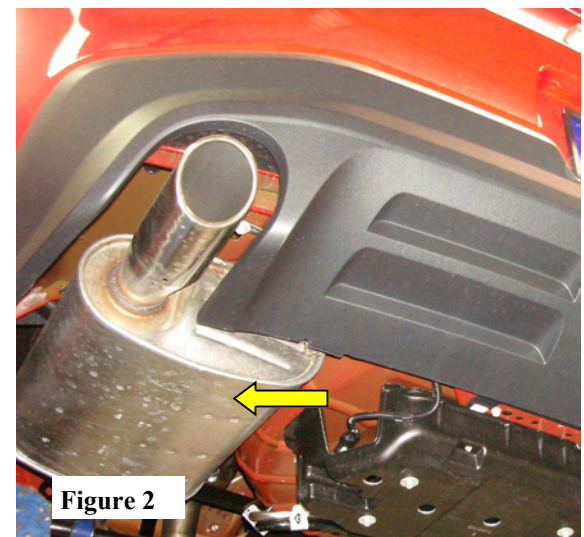
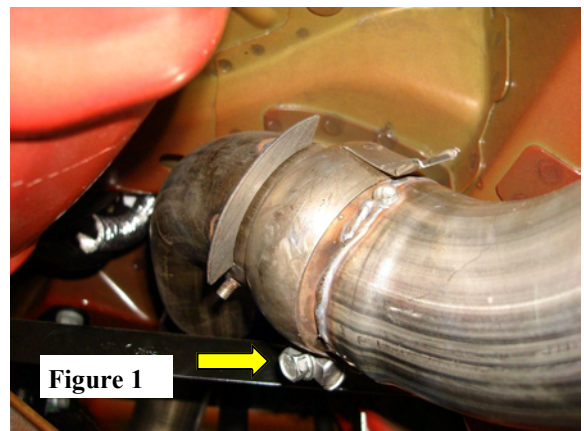

Borla Performance Exhaust System Installation

1. Insert the expanded end of the (driver-side) L/H muffler assembly into OE ball clamp and install the hangers into the rubber isolators. (See Fig. 3)
2. Repeat step 2 for the installation of the (passenger-side) R/H muffler assembly.
3. Check your exhaust system for proper clearance under the vehicle and also for tip alignment. (See Figs. 4)
4. Once position has been determined to be correct, tighten the Accuseal™ clamps to 32-35 ft. lbs.
7. Before starting your vehicle, make sure to check all wires, hoses, brake lines, body parts and tires for safe clearance from the exhaust system.
8. Start vehicle and check for any leaks. If any leaks are found, determine cause (such as loose or incorrectly positioned clamp) and repair as necessary.

Note: When you first start your vehicle after the installation of your new Borla Performance Exhaust System, there may be some smoke and fumes coming from the system. This is a protective oil based coating used in the manufacturing of mandrel bent performance exhaust tubing. This is not a problem and will disappear within a very short period of time after the exhaust has reached normal operating temperatures.

Congratulations!!! You have completed the installation of the world famous Borla Performance Stainless Steel Exhaust System.

