

Installation for the FORD F-150 Truck PNs - 140617, 140618, 140619 (145" wheelbase)



These instructions have been written to help you with the installation of your Borla Performance Exhaust System. Please read this document completely before beginning the installation of your system.

Please compare the parts in the box with the bill of materials provided to assure that you have all the parts necessary for this installation.

Thank you for purchasing a Borla Performance Cat-Back™ Exhaust System.

Borla Performance Cat-Back™ Exhaust Systems (PN's 140617, 140618, 140619) are designed for the Ford F-150 (145" wheelbase) equipped with the 2.7L & 3.5L EcoBoost V6 or the 5.0L V8 engines, 2 or 4-wheel drive, automatic transmissions.

**Borla Performance Adaptor Pipes (PN's 60564, 60556) extend the above Cat-Back™ Exhaust Systems to fit the following wheelbases: 60564 extends fitment to the 163" wheelbase, 60556 extends fitment to the 157" wheelbase. These systems are not included and must be purchased separately.*

Borla Performance Industries recommends that an exhaust shop or professional after market parts installer perform the installation of this system. However, if you decide to perform the installation on your own it is recommended that two people are used. This installation should not be performed by one person due to the risk of injury. Ensure the installers use all under car safety precautions including eye protection.

Please take time to read and understand the following...

By installing your Borla Performance Exhaust System, you indicate that you have read this document and you agree with the terms stated below.

It is the responsibility of the purchaser to follow all installation instruction guidelines and safety procedures supplied with your Borla Performance Exhaust System.

Borla Performance Industries assumes no responsibility for damages occurring from misuse, abuse, improper installation, improper operation, lack of responsible care, or all previously stated reasons resulting from incompatibility with other manufacturer's products and/or systems.

Included with your Borla Performance Exhaust System is a warranty card. Please read it carefully before you begin any work on your vehicle. If you should have any questions regarding our warranty policy, installation, or any other matter pertaining to your new Borla Performance Exhaust System, please give us a call at the number provided on the warranty card.

Minimum Required Tool List:

TOOLS:

- 1 3/8" Drive Ratchet
- 2 3/8" Drive Extension 3"
- 3 15mm Deep Well Socket
- 5 Pry Bar

SHOP SUPPLIES:

- 1 Spray Lubricant

Borla Performance Cat-Back™ Bill of Materials

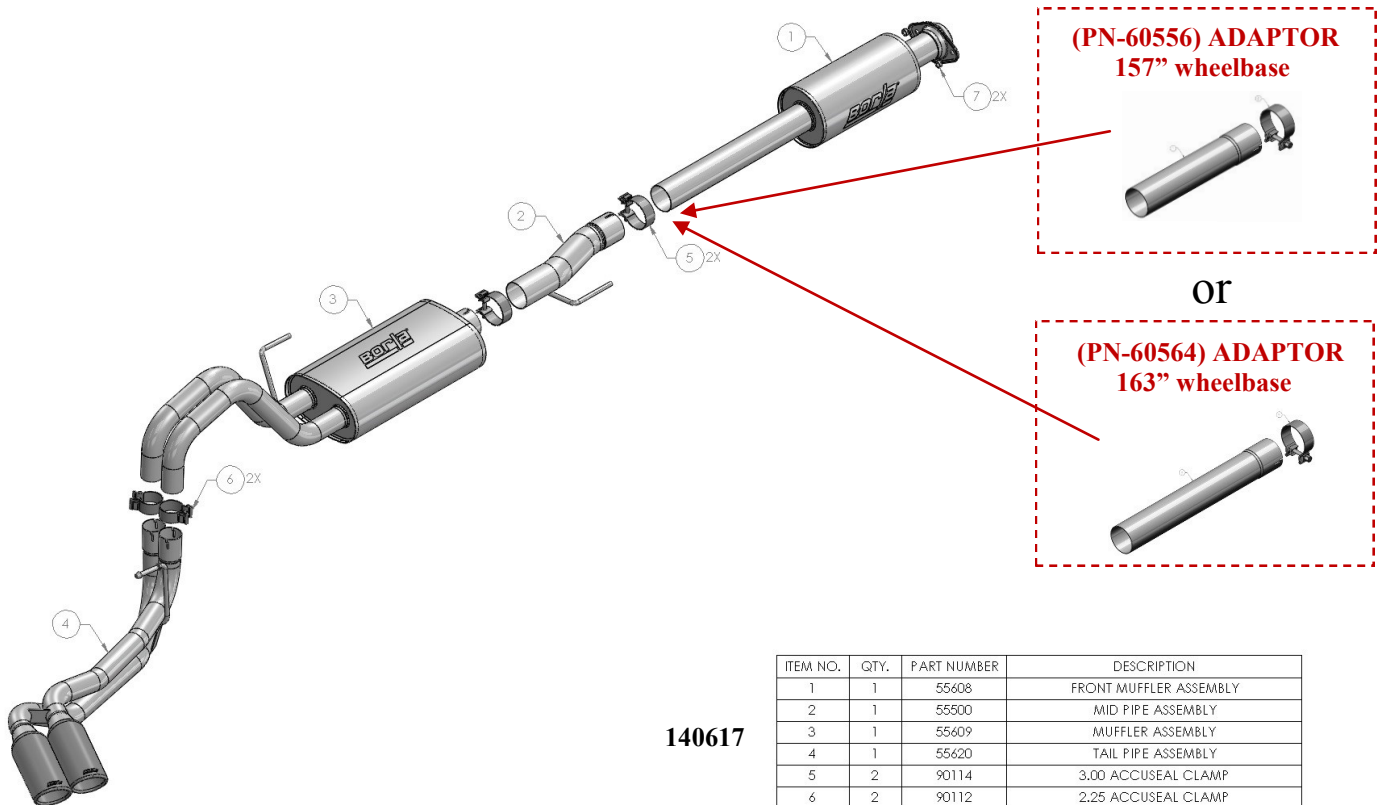

ITEM NO.	QTY.	PART NUMBER	DESCRIPTION
1	1	55608	FRONT MUFFLER ASSEMBLY
2	1	55500	MID PIPE ASSEMBLY
3	1	55609	MUFFLER ASSEMBLY
4	1	55620	TAIL PIPE ASSEMBLY
5	2	90114	3.00 ACCUSEAL CLAMP
6	2	90112	2.25 ACCUSEAL CLAMP
7	2	11514597	NUT: HXHD, M10 X 1.50p

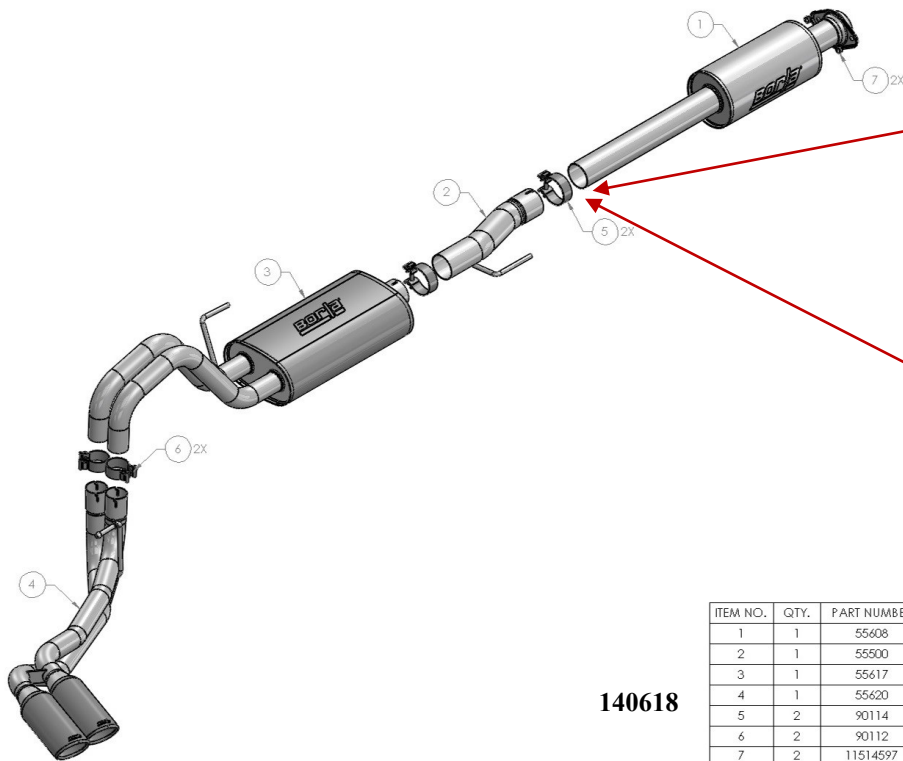

140618



OR



ITEM NO.	QTY.	PART NUMBER	DESCRIPTION
1	1	55608	FRONT MUFFLER ASSEMBLY
2	1	55500	MID PIPE ASSEMBLY
3	1	55617	MUFFLER ASSEMBLY
4	1	55620	TAIL PIPE ASSEMBLY
5	2	90114	3.00 ACCUSEAL CLAMP
6	2	90112	2.25 ACCUSEAL CLAMP
7	2	11514597	NUT: HXHD, M10 X 1.50p

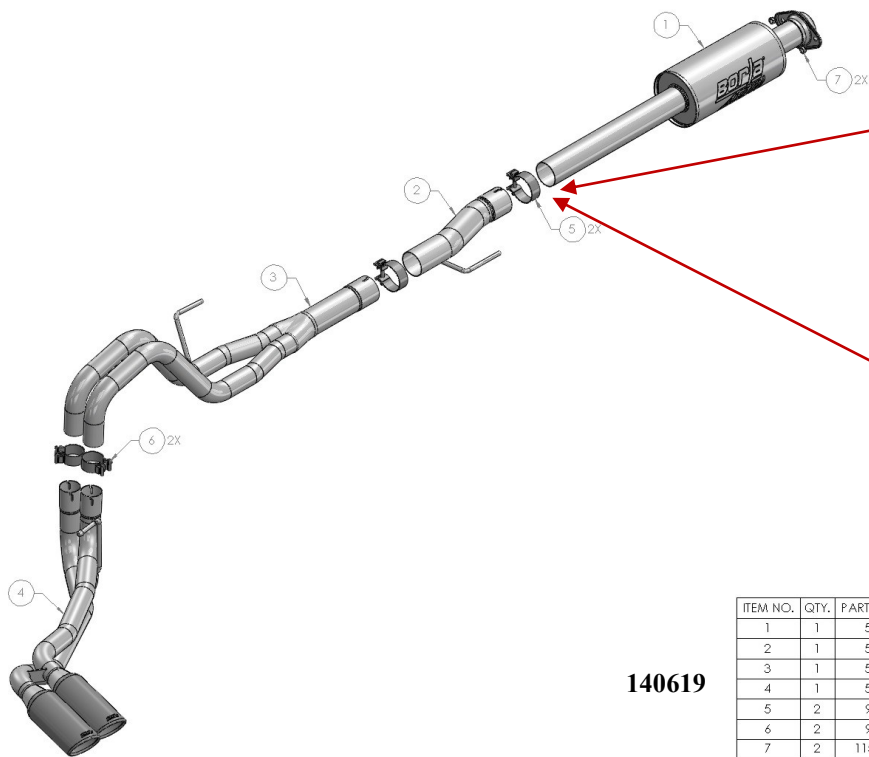

140619



OR



ITEM NO.	QTY.	PART NUMBER	DESCRIPTION
1	1	55619	FRONT MUFFLER ASSEMBLY
2	1	55500	MID PIPE ASSEMBLY
3	1	55618	Y-PIPE ASSEMBLY
4	1	55620	TAIL PIPE ASSEMBLY
5	2	90114	3.00 ACCUSEAL CLAMP
6	2	90112	2.25 ACCUSEAL CLAMP
7	2	11514597	NUT: HXHD, M10 X 1.50p

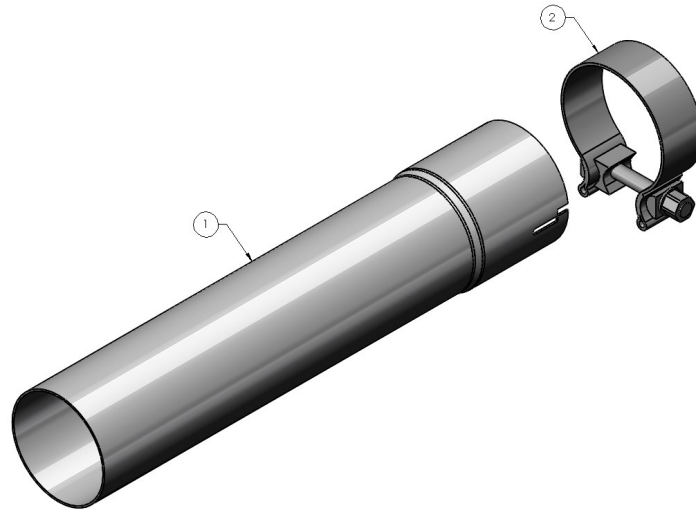

(PN-60556) ADAPTOR
157" wheelbase

ITEM NO.	QTY.	PART NUMBER	DESCRIPTION
1	1	68920	EXTENSION PIPE: Ø3.00 X 15.00"
2	1	90114	3.00 ACCUSEAL CLAMP

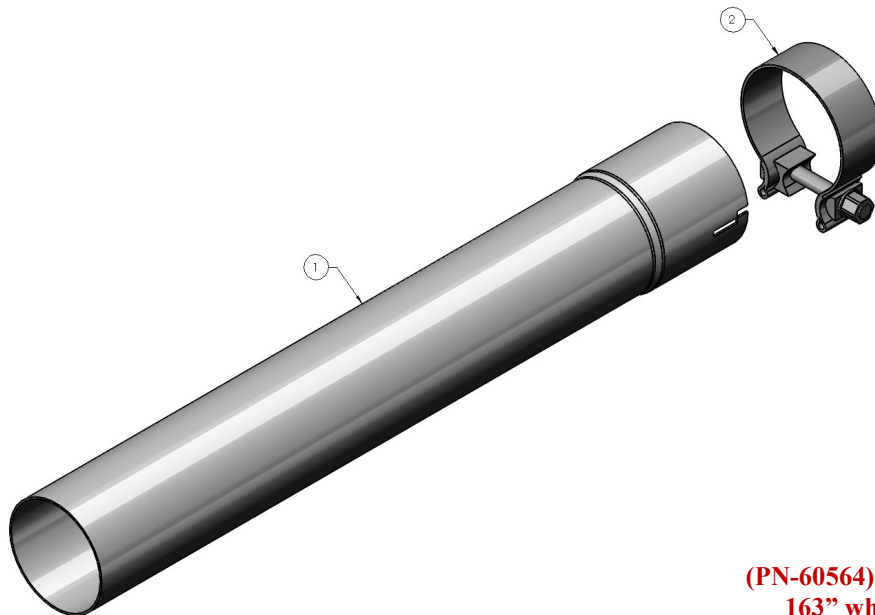

(PN-60564) ADAPTOR
163" wheelbase

ITEM NO.	QTY.	PART NUMBER	DESCRIPTION
1	1	68921	EXTENSION PIPE: Ø3.00 X 21.00"
2	1	90114	3.00 ACCUSEAL CLAMP

Caution!!! *Never work on a hot exhaust system. Serious injury in the form of burns can result* If the vehicle has been in use and the exhaust system is hot, allow vehicle to cool for at least 1 hour. Always wear eye protection when working under any vehicle.

Note: It is our recommendation that you use a hoist or hydraulic lift to facilitate the installation of your new Borla Performance Cat-Back™ Exhaust System.

Taking all under car safety precautions, lift the vehicle using a hoist or hydraulic lift. Once this has been done, you may begin the removal of your old exhaust system from your vehicle.

Note: Before removing the original exhaust system from your vehicle, please compare the parts you have received with the bill of materials provided on the previous page to assure that you have all the parts necessary for the installation of your new Borla Performance Cat-Back™ Exhaust System.

Original Exhaust System Removal

Note: With a used vehicle, we suggest a penetrating spray lubricant to be applied liberally to all exhaust fasteners and allowing a significant period of time for the chemical to lubricate the threads before attempting to disassemble.

1. Unbolt the clamp located in front of the muffler assembly and remove the hangers from rubber isolators. (See Fig. 1)
2. Using a muffler stand or an additional person to support the exhaust system, loosen and slide the clamp behind the OE muffler. Remove the hangers from the rubber isolators and remove the exhaust system from the vehicle. (See Figs. 2 & 3)
3. Remove the original isolator bracket from vehicle and transfer to your new Borla system. (See Fig. 4)

Warning: Use extreme caution during installation. Torque all fasteners according to manufacturer's torque values and tightening sequence. **DO NOT** use air impact tools to tighten fasteners on Borla Performance Exhaust Systems. Use of such tools may result in bent flanges or gasket contact areas leading to exhaust leaks.

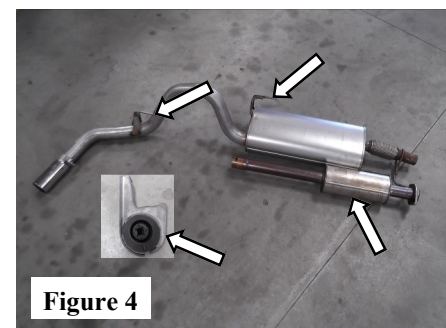
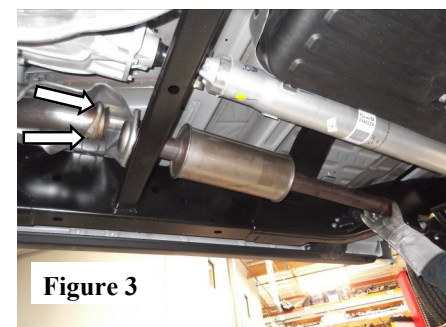
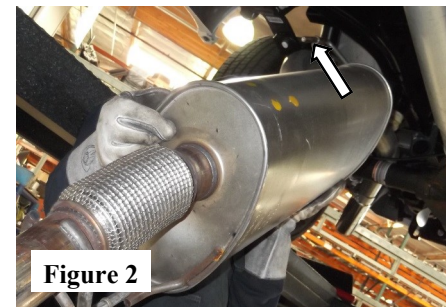
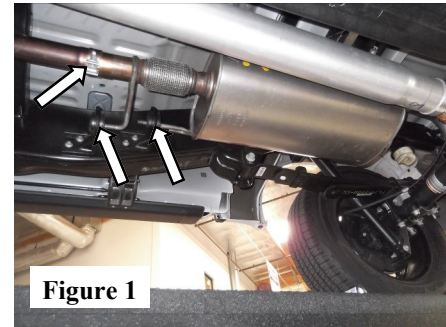

Borla Performance Cat-Back™ Exhaust System Installation

1. Place **Front Muffler Assembly** using the original hardware. (See Fig. 5) Lightly tighten the bolts.
2. Place a clamp over the expanded end of the **Mid Pipe Assembly** and insert the inlet to the **Front Muffler Assembly**. Do not tighten the clamp.
3. **Install Adaptor Pipes 60556 or 60564 (if required).** Place a clamp over the expanded end of the **Extension Pipe** and insert into outlet of the **Front Muffler Assembly**. Do not tighten the clamp.
4. Place a clamp over the expanded end of the **Mid Pipe Assembly** and insert the inlet into the outlet of the **Front Muffler Assembly** or **Extension Pipe**. Insert the hanger into the rubber isolator. Do not tighten the clamp.
5. Place a clamp over the expanded end of the **Muffler Assembly** and insert the inlet into the **Mid Pipe Assembly**. Insert the hanger into the rubber isolator. (See Fig. 6) Do not tighten the clamp.
6. Place a clamp over the expanded end of the **Tail Pipe Assembly** and insert inlet to the right-side outlet of the **Muffler Assembly**. Insert hanger into installed right-side-side **Hanger Bracket Assembly**. Do not tighten the clamp. (See Fig. 7)
7. Check tip position parallel to bottom edge of fender. Once position has been determined to be correct, tighten the Accuseal clamps to 32-35 ft. lbs. (See Fig. 8)
8. Before starting your vehicle, make sure to check all wires, hoses, brake lines, body parts and tires for safe clearance from the exhaust system.
9. Start vehicle and check for any leaks. If any leaks are found, determine cause (such as loose or incorrectly positioned clamp) and repair as necessary.

Note: When you first start your vehicle after the installation of your new Borla Performance Exhaust System, there may be some smoke and fumes coming from the system. This is a protective oil based coating used in the manufacturing of mandrel bent performance exhaust tubing. This is not a problem and will disappear within a very short period of time after the exhaust has reached normal operating temperatures.

**Figure 5****Figure 6****Figure 7****Figure 8**