

Exhaust System Installation

PN's - 140557, 140558, 140559, 140560, 140568, 140569



These instructions have been written to help you with the installation of your Borla [Performance Exhaust System](#). Please read this document completely before beginning the installation of your system.

Please compare the parts in the box with the bill of materials provided to assure that you have all the parts necessary for this installation.

Thank you for purchasing a Borla Performance Cat-Back™ Exhaust System.

Borla Performance Cat-Back™ Exhaust Systems (PN's 140557, 140558, 140568, 140569) are designed for the Chevrolet Tahoe, GMC Yukon and Yukon XL equipped with a 5.3L V8 engine, 2 or 4-WD automatic transmission.

Borla Performance Cat-Back™ Exhaust Systems (PN's 140559, 140560) are designed for the Cadillac Escalade equipped with a 6.2L V8 engine, 2 or 4-WD automatic transmission.

Borla Performance Industries recommends that an exhaust shop or professional after market parts installer perform the installation of this system. However, if you decide to perform the installation on your own it is recommended that two people are used. This installation should not be performed by one person due to the risk of injury. Ensure the installers use all under car safety precautions including eye protection.

Please take time to read and understand the following...

By installing your Borla Performance Exhaust System, you indicate that you have read this document and you agree with the terms stated below.

It is the responsibility of the purchaser to follow all installation instruction guidelines and safety procedures supplied with your Borla Performance Exhaust System.

Borla Performance Industries assumes no responsibility for damages occurring from misuse, abuse, improper installation, improper operation, lack of responsible care, or all previously stated reasons resulting from incompatibility with other manufacturer's products and/or systems.

Included with your Borla Performance Exhaust System is a warranty card. Please read it carefully before you begin any work on

Minimum Required Tool List:

TOOLS:

1. 3/8" Drive Ratchet
2. 3/8" Drive Extension 3"
3. 15mm Deep Well Socket
4. 13mm Socket
5. 19mm Socket
6. 19mm Wrench
7. Pry Bar

SHOP SUPPLIES:

- 1 Spray Lubricant

Borla Performance Cat-back™ Bill of Materials

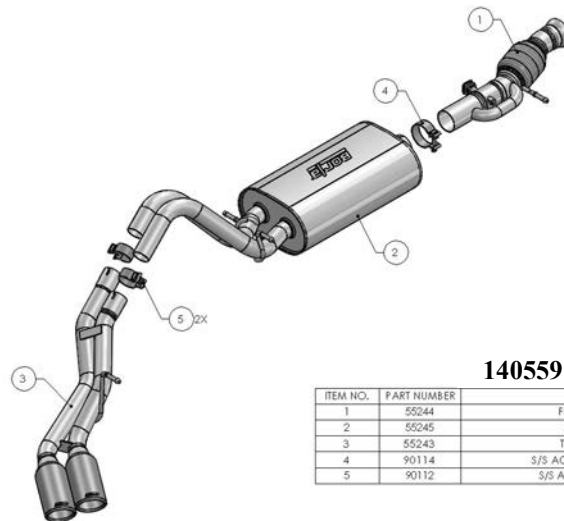

140559

ITEM NO.	PART NUMBER	DESCRIPTION	QTY.
1	55244	FRONT PIPE ASSEMBLY	1
2	55245	MUFFLER ASSEMBLY	1
3	55243	TAIL PIPE ASSEMBLY	1
4	90114	S/S ACCUSEAL CLAMP Ø3.00	1
5	90112	S/S ACCUSEAL CLAMP Ø2.25	2

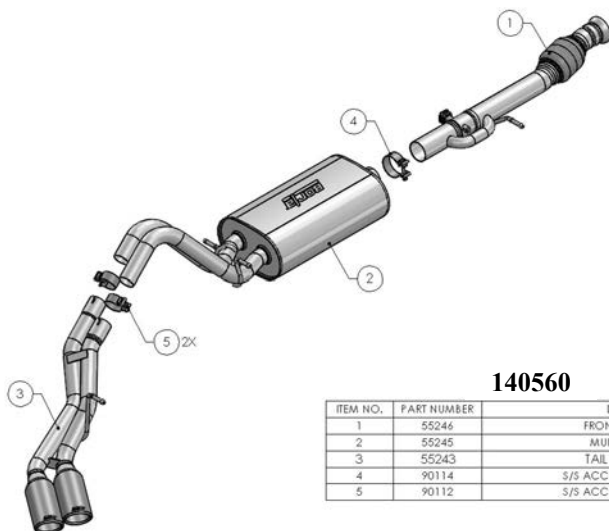

140560

ITEM NO.	PART NUMBER	DESCRIPTION	QTY.
1	55244	FRONT PIPE ASSEMBLY	1
2	55245	MUFFLER ASSEMBLY	1
3	55243	TAIL PIPE ASSEMBLY	1
4	90114	S/S ACCUSEAL CLAMP Ø3.00	1
5	90112	S/S ACCUSEAL CLAMP Ø2.25	2

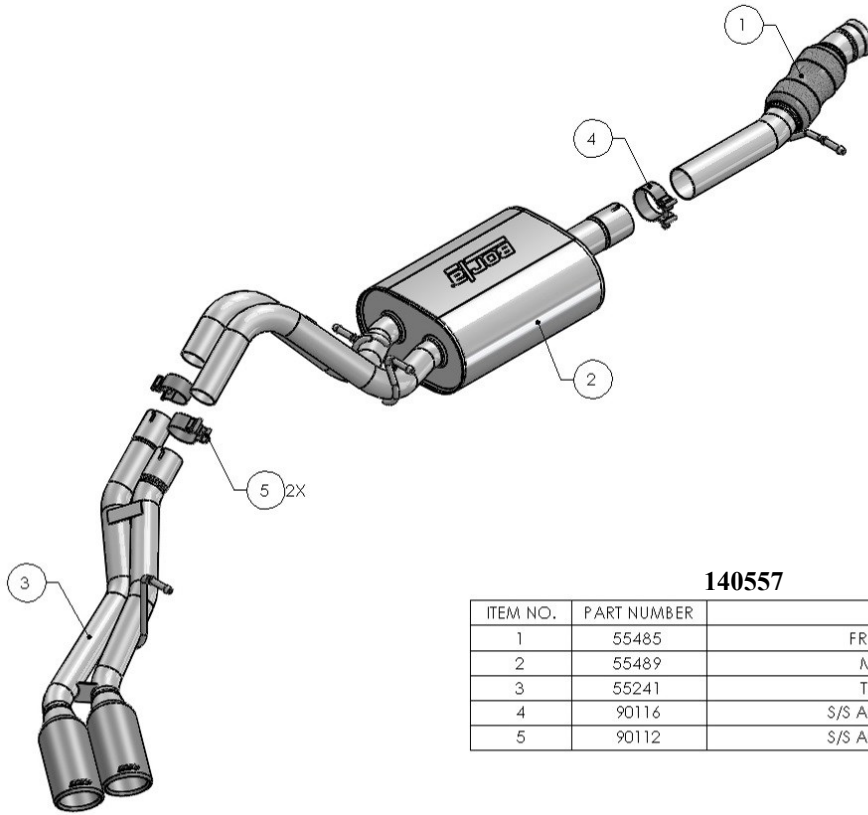

140557

ITEM NO.	PART NUMBER	DESCRIPTION	QTY.
1	55485	FRONT PIPE ASSEMBLY	1
2	55489	MUFFLER ASSEMBLY	1
3	55241	TAIL PIPE ASSEMBLY	1
4	90116	S/S ACCUSEAL CLAMP Ø2.75	1
5	90112	S/S ACCUSEAL CLAMP Ø2.25	2

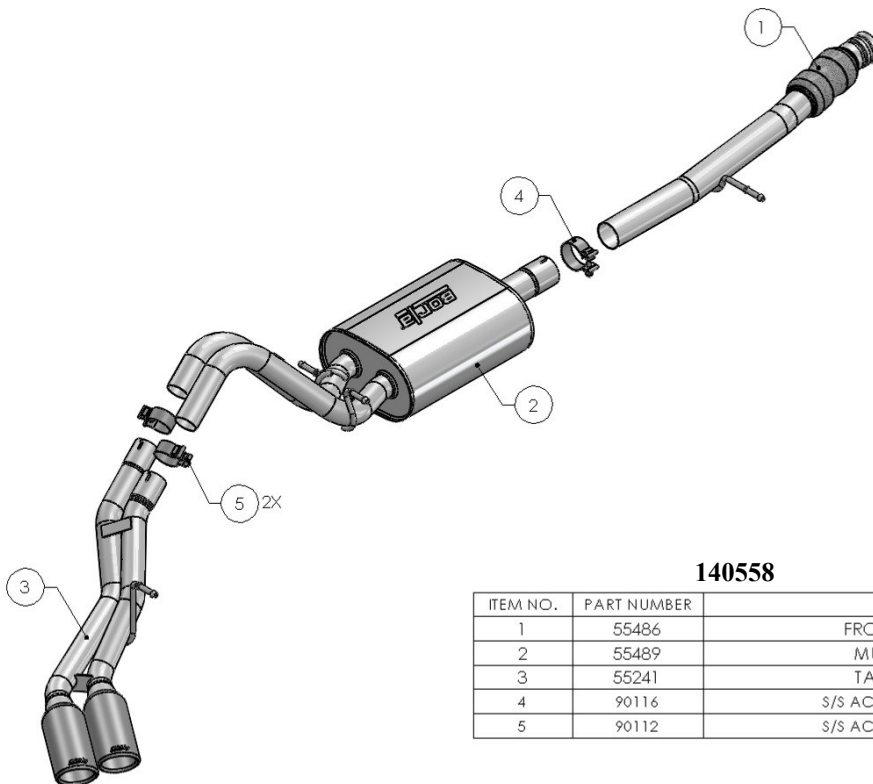

140558

ITEM NO.	PART NUMBER	DESCRIPTION	QTY.
1	55486	FRONT PIPE ASSEMBLY	1
2	55489	MUFFLER ASSEMBLY	1
3	55241	TAIL PIPE ASSEMBLY	1
4	90116	S/S ACCUSEAL CLAMP Ø2.75	1
5	90112	S/S ACCUSEAL CLAMP Ø2.25	2

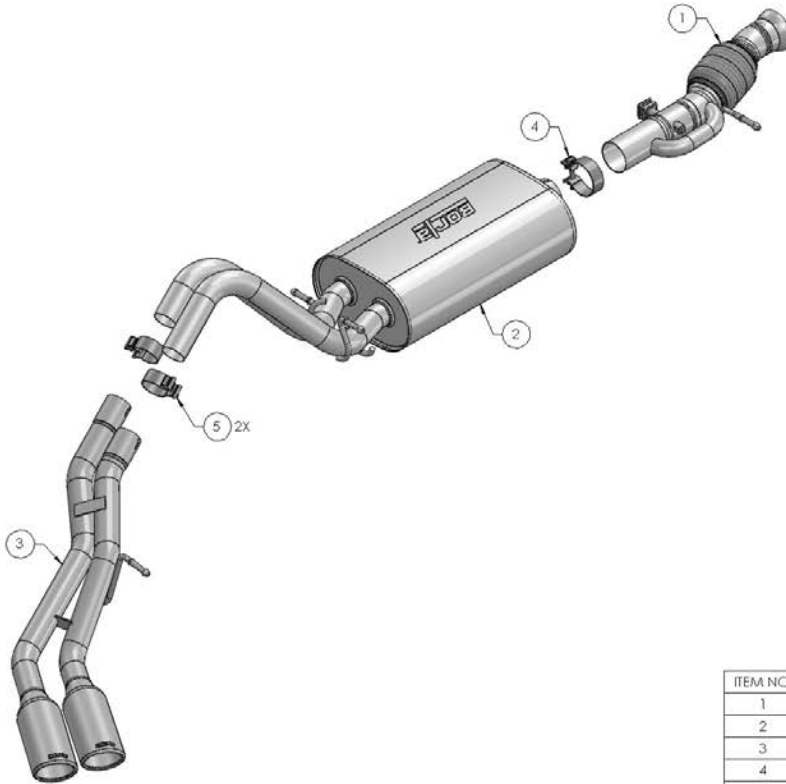

140568

ITEM NO.	QTY.	PART NUMBER	DESCRIPTION
1	1	55244	FRONT PIPE ASSEMBLY
2	1	55245	MUFFLER ASSEMBLY
3	1	55241	TAILPIPE ASSEMBLY
4	1	90114	3.00 ACCUSEAL CLAMP
5	2	90112	2.25 ACCUSEAL CLAMP

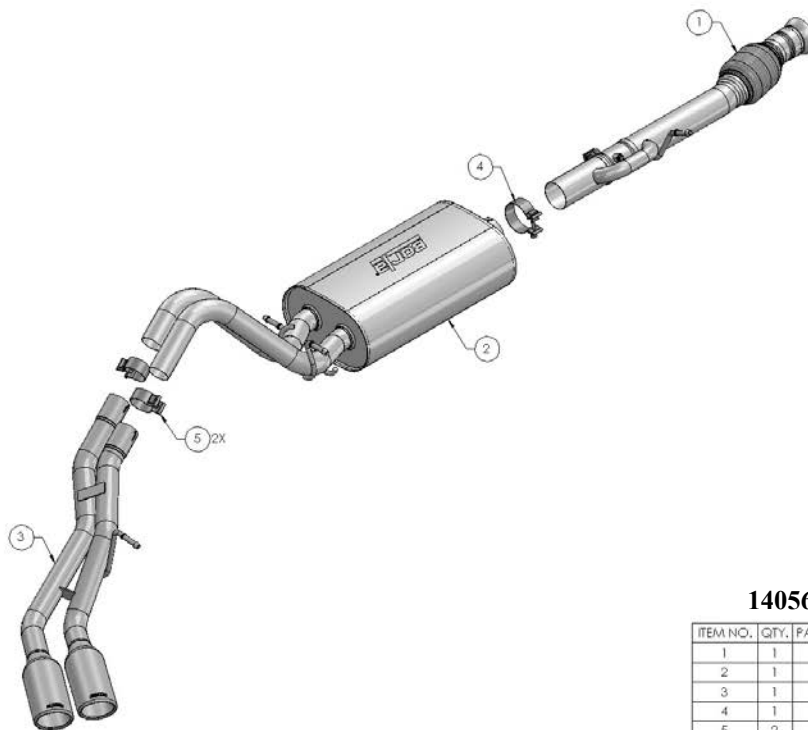

140569

ITEM NO.	QTY.	PART NUMBER	DESCRIPTION
1	1	55246	FRONT PIPE ASSEMBLY
2	1	55245	MUFFLER ASSEMBLY
3	1	55241	TAILPIPE ASSEMBLY
4	1	90114	3.00 ACCUSEAL CLAMP
5	2	90112	2.25 ACCUSEAL CLAMP

Caution!!! Never work on a hot exhaust system. Serious injury in the form of burns can result If the vehicle has been in use and the exhaust system is hot, allow vehicle to cool for at least 1 hour. Always wear eye protection when working under any vehicle.

Note: It is our recommendation that you use a hoist or hydraulic lift to facilitate the installation of your new Borla Performance Cat-Back Exhaust System.

Taking all under car safety precautions, lift the vehicle using a hoist or hydraulic lift. Once this has been done, you may begin the removal of your old exhaust system from your vehicle.

Note: Before removing the original exhaust system from your vehicle, please compare the parts you have received with the bill of materials provided on the previous page to assure that you have all the parts necessary for the installation of your new Borla Performance Cat-Back Exhaust System.

Original Exhaust System Removal

Note: With a used vehicle, we suggest a penetrating spray lubricant to be applied liberally to all exhaust fasteners and allowing a significant period of time for the chemical to lubricate the threads before attempting to disassemble.

1. Unbolt the clamp behind the catalytic converter. (See Fig. 1)
2. Unbolt the sway bar for more clearance and place the hardware aside for reinstallation later. (See Fig. 2)
3. Lubricate all the hangers and rubber isolators. (See Fig. 3)
4. Support the rear muffler assembly in position using a muffler stand or additional person.
5. Remove the hangers from the rubber isolators and remove the rear muffler assembly from the vehicle.

Warning: Use extreme caution during installation. Torque all fasteners according to manufacturer's torque values and tightening sequence. **DO NOT** use air impact tools to tighten fasteners on Borla Performance Exhaust Systems. Use of such tools may result in bent flanges or gasket contact areas leading to exhaust leaks.

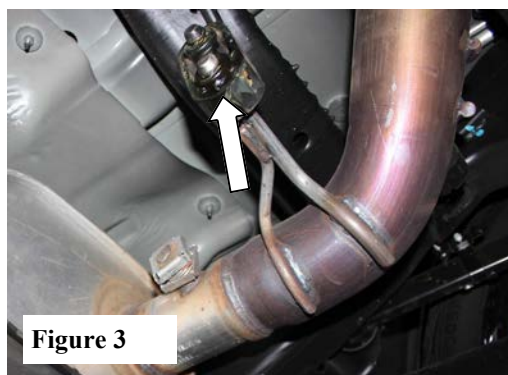
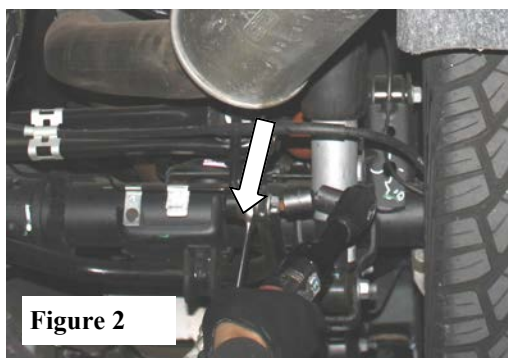
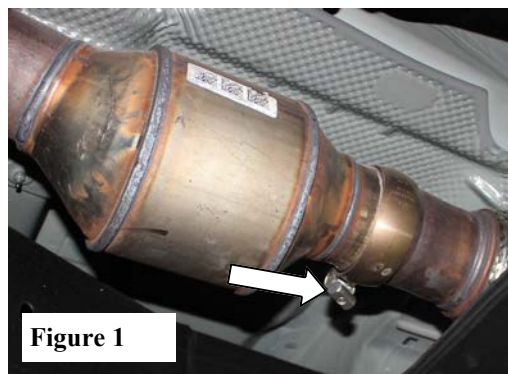

Borla Performance Cat-Back™ Exhaust System Installation

1. Place the front pipe into position making sure to install the hanger into the rubber isolator. (See Fig. 4)
2. Place a clamp over the expanded end of the muffler assembly and set it into position. (See Fig. 5) Do Not tighten the clamp.
3. Place a clamp over the expanded ends of the tail pipe assembly and set it into position making sure to install the hangers into the rubber isolators. (See Fig. 6) Do Not tighten the clamps.
4. Check your exhaust system for proper clearance under the vehicle and also for tip alignment. (See Fig. 7)
5. Once position has been determined to be correct, tighten the Accuseal™ clamps to 32-35 ft. lbs. making sure the clamp opening is not over any of the notches in the pipe and tighten the flange hardware to 18-22 ft. lbs.
6. Using the original hardware, reinstall the heat shield. Reinstall the spare tire as recommended by vehicle manufacturer.
7. Before starting your vehicle, make sure to check all wires, hoses, brake lines, body parts and tires for safe clearance from the exhaust system.
8. Start vehicle and check for any leaks. If any leaks are found, determine cause (such as loose hardware or incorrectly positioned clamp) and repair as necessary.

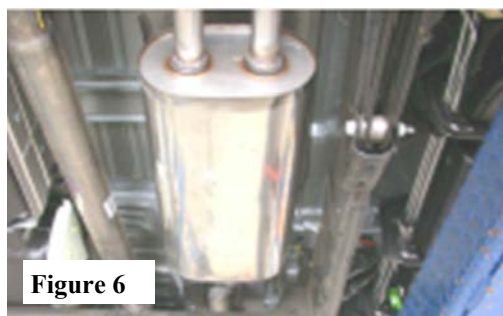
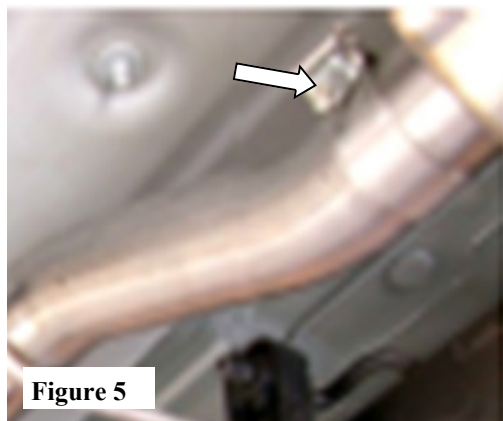
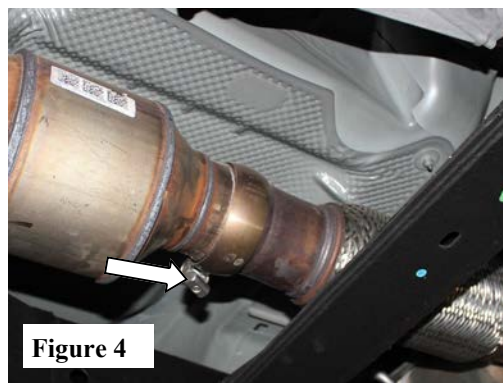

Note: When you first start your vehicle after the installation of your new Borla Performance Exhaust System, there may be some smoke and fumes coming from the system. This is a protective oil based coating used in the manufacturing of mandrel bent performance exhaust tubing. This is not a problem and will disappear within a very short period of time after the exhaust has reached normal operating temperatures.