



Exhaust System Installation for Chevrolet Silverado and GMC Sierra PN-140535, 140536, 140537, 140538, 140539, 140540



Thank you for purchasing a Borla Performance Cat-Back™ Exhaust System.

Borla Performance Cat-Back™ Exhaust Systems (PNs - 140535, 140536, 140537, 140538, 140539, 140540) are designed for Chevrolet Silverado & GMC Sierra 1500, 6.2L V8 engine, 2WD and 4WD, automatic transmission.

Borla Performance Industries recommends that an exhaust shop or professional after market parts installer perform the installation of this system. However, if you decide to perform the installation on your own it is recommended that two people are used. This installation should not be performed by one person due to the risk of injury. Ensure the installers use all under car safety precautions including eye protection.

Please take time to read and understand the following...

By installing your Borla Performance Exhaust System, you indicate that you have read this document and you agree with the terms stated below. It is the responsibility of the purchaser to follow all installation instruction guidelines and safety procedures supplied with your Borla Performance Exhaust System.

Borla Performance Industries assumes no responsibility for damages occurring from misuse, abuse, improper installation, improper operation, lack of responsible care, or all previously stated reasons resulting from incompatibility with other manufacturer's products and/or systems.

Included with your Borla Performance Exhaust System is a warranty card. Please read it carefully before you begin any work on your vehicle. If you should have any questions regarding our warranty policy, installation, or any other matter pertaining to your new Borla Performance Exhaust System, please give us a call at the number provided on the warranty card.

Minimum Required Tool List:

TOOLS:

1. 3/8" Drive Ratchet
2. 3/8" Drive Extension 3"
3. 15mm Socket
4. Pry Bar

SHOP SUPPLIES:

- 1 Spray Lubricant

Borla Performance Cat-back™ Bill of Materials

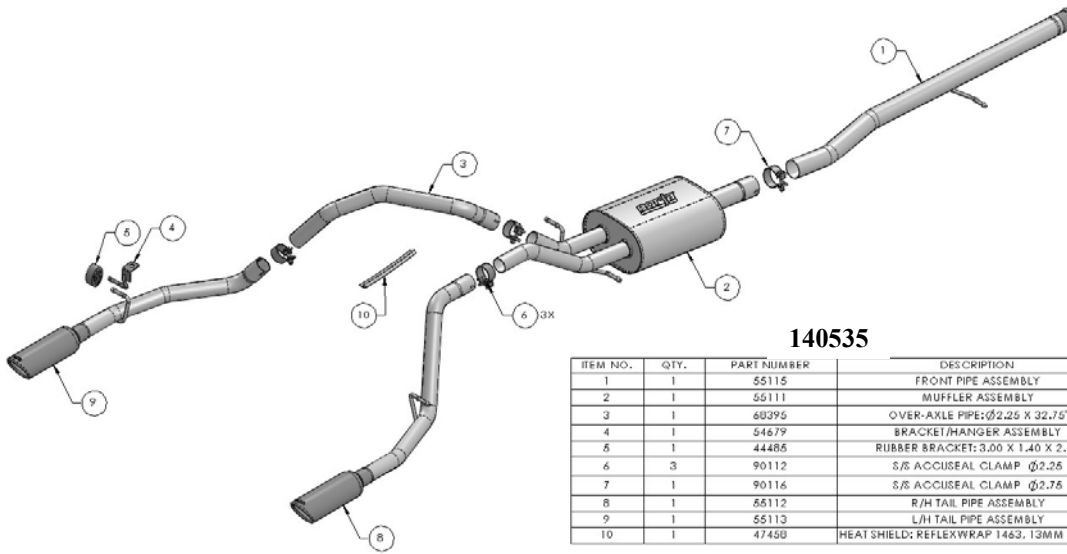

140535

ITEM NO.	QTY.	PART NUMBER	DESCRIPTION
1	1	55115	FRONT PIPE ASSEMBLY
2	1	55111	MUFFLER ASSEMBLY
3	1	68395	OVER-AXLE PIPE: $\phi 2.25 \times 32.75"$
4	1	54679	BRACKET/HANGER ASSEMBLY
5	1	44485	RUBBER BRACKET: 3.00 X 1.40 X 2.12"
6	3	90112	S/S ACCUSEAL CLAMP $\phi 2.25$
7	1	90116	S/S ACCUSEAL CLAMP $\phi 2.75$
8	1	55112	R/H TAIL PIPE ASSEMBLY
9	1	55113	L/H TAIL PIPE ASSEMBLY
10	1	47450	HEAT SHIELD: REFLEXWRAP 1463, 13MM X 254MM

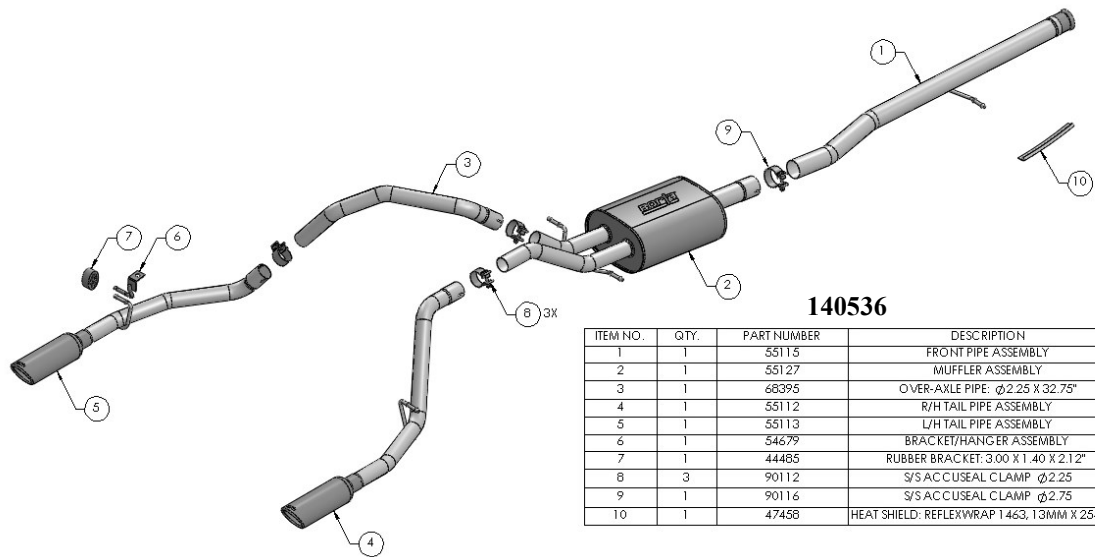

140536

ITEM NO.	QTY.	PART NUMBER	DESCRIPTION
1	1	55115	FRONT PIPE ASSEMBLY
2	1	55127	MUFFLER ASSEMBLY
3	1	68395	OVER-AXLE PIPE: $\phi 2.25 \times 32.75"$
4	1	55112	R/H TAIL PIPE ASSEMBLY
5	1	55113	L/H TAIL PIPE ASSEMBLY
6	1	54679	BRACKET/HANGER ASSEMBLY
7	1	44485	RUBBER BRACKET: 3.00 X 1.40 X 2.12"
8	3	90112	S/S ACCUSEAL CLAMP $\phi 2.25$
9	1	90116	S/S ACCUSEAL CLAMP $\phi 2.75$
10	1	47458	HEAT SHIELD: REFLEXWRAP 1463, 13MM X 254MM

Minimum Required Tool List:

TOOLS:

1. 3/8" Drive Ratchet
2. 3/8" Drive Extension 3"
3. 15mm Socket
4. Pry Bar

SHOP SUPPLIES:

- 1 Spray Lubricant

Borla Performance Cat-back™ Bill of Materials

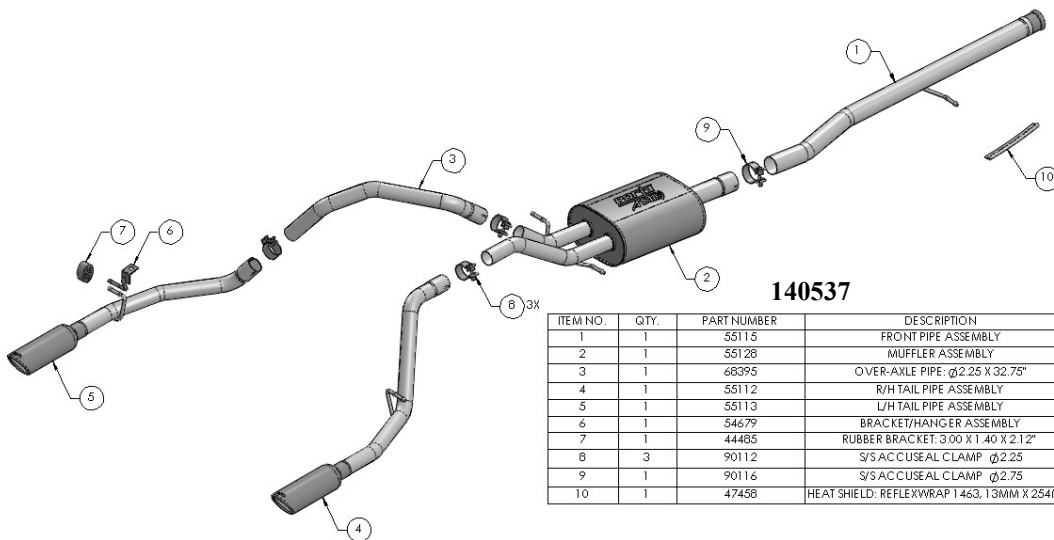

140537

ITEM NO.	QTY.	PART NUMBER	DESCRIPTION
1	1	55115	FRONT PIPE ASSEMBLY
2	1	55126	MUFFLER ASSEMBLY
3	1	68395	OVER-AXLE PIPE: Ø2.25 X 32.75"
4	1	55112	R/H TAIL PIPE ASSEMBLY
5	1	55113	L/H TAIL PIPE ASSEMBLY
6	1	54679	BRACKET/HANGER ASSEMBLY
7	1	44485	RUBBER BRACKET: 3.00 X 1.40 X 2.12"
8	3	90112	S/S ACCUSEAL CLAMP Ø2.25
9	1	90116	S/S ACCUSEAL CLAMP Ø2.75
10	1	47458	HEAT SHIELD: REFLEXWRAP 1463, 13MM X 254MM

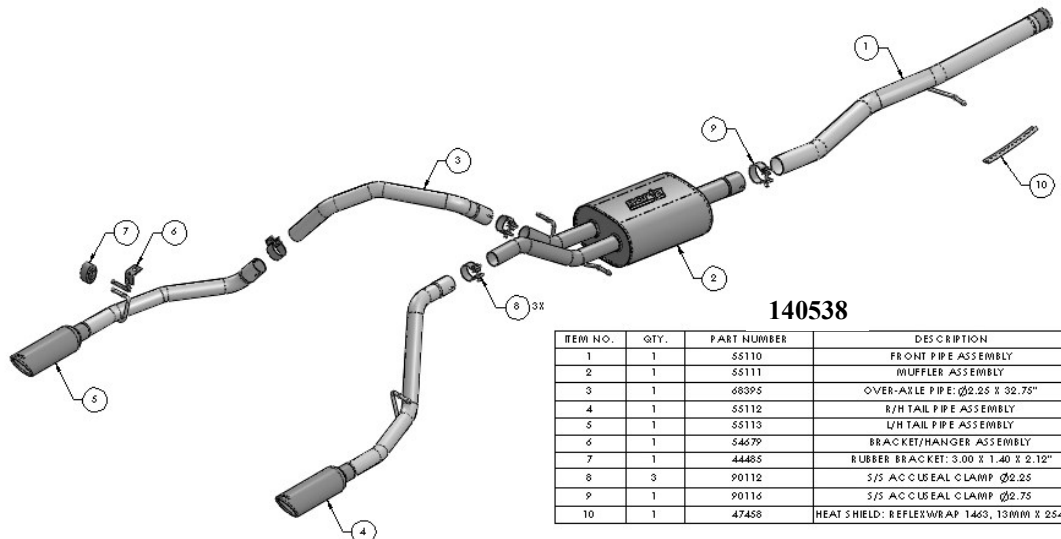

140538

ITEM NO.	QTY.	PART NUMBER	DESCRIPTION
1	1	55110	FRONT PIPE ASSEMBLY
2	1	55111	MUFFLER ASSEMBLY
3	1	68395	OVER-AXLE PIPE: Ø2.25 X 32.75"
4	1	55112	R/H TAIL PIPE ASSEMBLY
5	1	55113	L/H TAIL PIPE ASSEMBLY
6	1	54679	BRACKET/HANGER ASSEMBLY
7	1	44485	RUBBER BRACKET: 3.00 X 1.40 X 2.12"
8	3	90112	S/S ACCUSEAL CLAMP Ø2.25
9	1	90116	S/S ACCUSEAL CLAMP Ø2.75
10	1	47458	HEAT SHIELD: REFLEXWRAP 1463, 13MM X 254MM

Minimum Required Tool List:

TOOLS:

1. 3/8" Drive Ratchet
2. 3/8" Drive Extension 3"
3. 15mm Socket
4. Pry Bar

SHOP SUPPLIES:

- 1 Spray Lubricant

Borla Performance Cat-back™ Bill of Materials

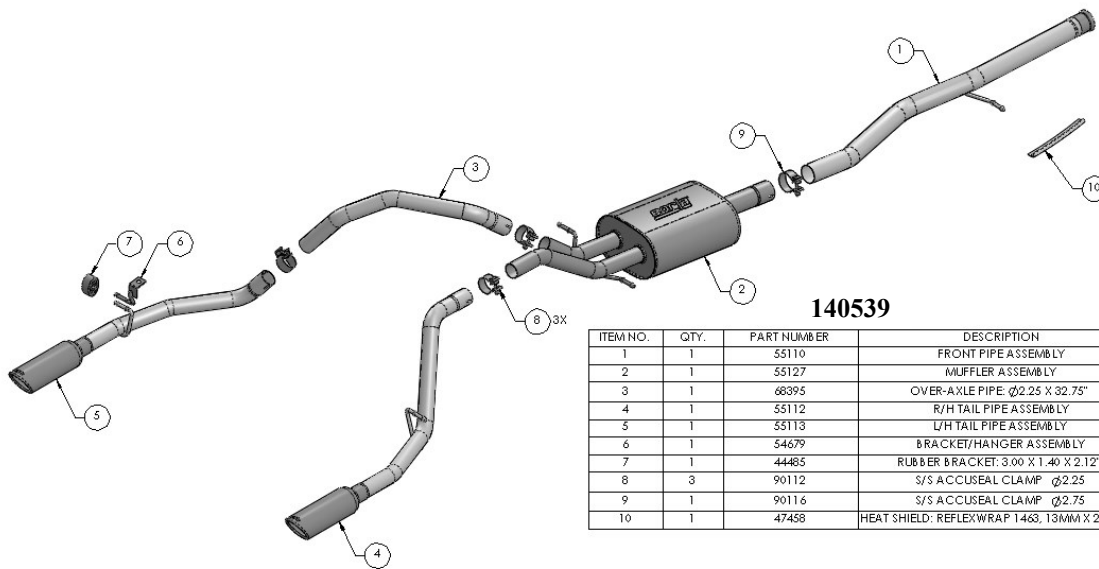

140539

ITEM NO.	QTY.	PART NUMBER	DESCRIPTION
1	1	55110	FRONT PIPE ASSEMBLY
2	1	55127	MUFFLER ASSEMBLY
3	1	68395	OVER-AXLE PIPE: $\varnothing 2.25 \times 32.75"$
4	1	55112	R/H TAIL PIPE ASSEMBLY
5	1	55113	L/H TAIL PIPE ASSEMBLY
6	1	54679	BRACKET/HANGER ASSEMBLY
7	1	44485	RUBBER BRACKET: 3.00 X 1.40 X 2.12"
8	3	90112	S/S ACCLUSEAL CLAMP $\varnothing 2.25$
9	1	90116	S/S ACCLUSEAL CLAMP $\varnothing 2.75$
10	1	47458	HEAT SHIELD: REFLEXWRAP 1463, 13MM X 254MM

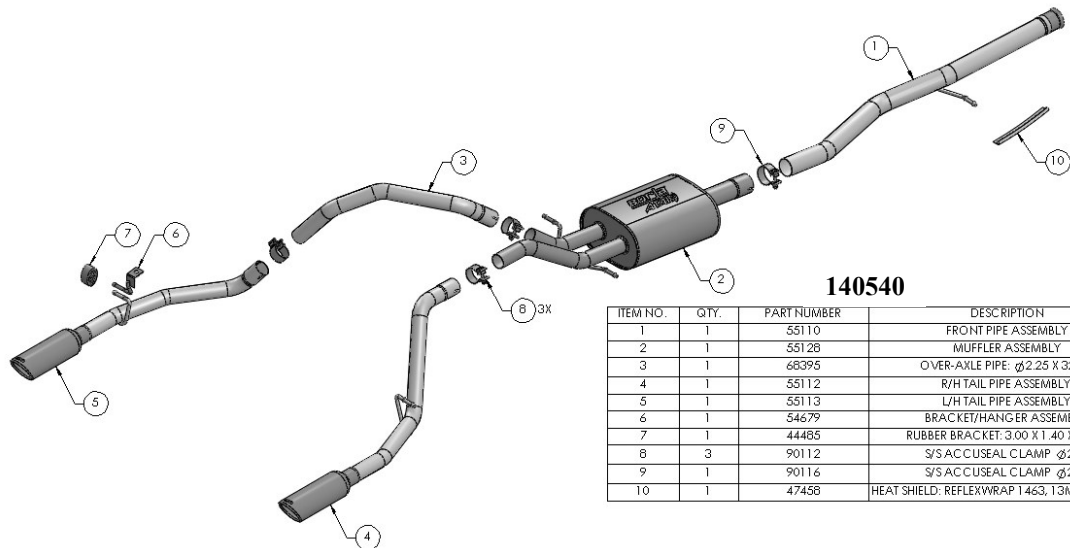

140540

ITEM NO.	QTY.	PART NUMBER	DESCRIPTION
1	1	55110	FRONT PIPE ASSEMBLY
2	1	55128	MUFFLER ASSEMBLY
3	1	68395	OVER-AXLE PIPE: $\varnothing 2.25 \times 32.75"$
4	1	55112	R/H TAIL PIPE ASSEMBLY
5	1	55113	L/H TAIL PIPE ASSEMBLY
6	1	54679	BRACKET/HANGER ASSEMBLY
7	1	44485	RUBBER BRACKET: 3.00 X 1.40 X 2.12"
8	3	90112	S/S ACCLUSEAL CLAMP $\varnothing 2.25$
9	1	90116	S/S ACCLUSEAL CLAMP $\varnothing 2.75$
10	1	47458	HEAT SHIELD: REFLEXWRAP 1463, 13MM X 254MM

Caution!!! Never work on a hot exhaust system. Serious injury in the form of burns can result if the vehicle has been in use and the exhaust system is hot, allow vehicle to cool for at least 1 hour. Always wear eye protection when working under any vehicle.

Note: It is our recommendation that you use a hoist or hydraulic lift to facilitate the installation of your new Borla Performance Exhaust System.

Taking all under car safety precautions, lift the vehicle using a hoist or hydraulic lift. Once this has been done, you may begin the removal of your old exhaust system from your vehicle.

Note: Before removing the original exhaust system from your vehicle, please compare the parts you have received with the bill of materials provided on the previous page to assure that you have all the parts necessary for the installation of your new Borla Performance Exhaust System.

Note: With a used vehicle, we suggest a penetrating spray lubricant to be applied liberally to all exhaust fasteners and allowing a significant period of time for the chemical to lubricate the threads before attempting to disassemble.

Original Exhaust System Removal

Note: With a used vehicle, we suggest a penetrating spray lubricant to be applied liberally to all exhaust fasteners and allowing a significant period of time for the chemical to lubricate the threads before attempting to disassemble.

1. Unbolt clamp located just after the catalytic converter. (See Fig. 1)
2. Place hardware to the side for use during the installation of your new exhaust system.
3. Lubricate all hangers and rubber isolators.
4. Remove the hangers from the rubber isolators and remove the exhaust. (See Fig. 2)
5. Using a muffler stand or an additional person to hold the exhaust and remove from vehicle. (See Fig. 3)

Warning: Use extreme caution during installation. Torque all fasteners according to manufacturer's torque values and tightening sequence. DO NOT use air impact tools to tighten fasteners on Borla Performance Exhaust Systems. Use of such tools may result in bent flanges or gasket contact areas leading to exhaust leaks.

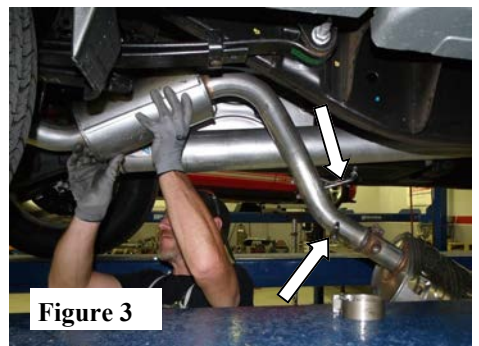
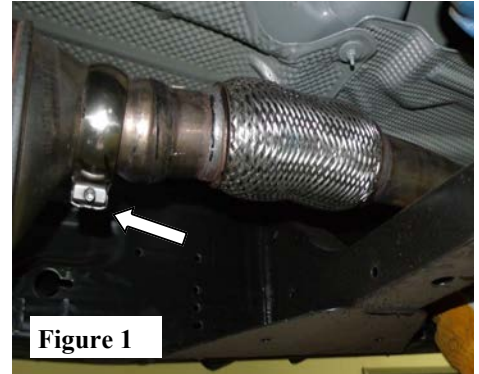

Caution!!! *Never work on a hot exhaust system. Serious injury in the form of burns can result if the vehicle has been in use and the exhaust system is hot, allow vehicle to cool for at least 1 hour. Always wear eye protection when working under any vehicle.*

Note: It is our recommendation that you use a hoist or hydraulic lift to facilitate the installation of your new Borla Performance Exhaust System.

Taking all under car safety precautions, lift the vehicle using a hoist or hydraulic lift. Once this has been done, you may begin the removal of your old exhaust system from your vehicle.

Note: Before removing the original exhaust system from your vehicle, please compare the parts you have received with the bill of materials provided on the previous page to assure that you have all the parts necessary for the installation of your new Borla Performance Exhaust System.

Borla Performance Cat-Back™ Exhaust System Installation

1. Using the original hardware, place the **Front Pipe Assembly** into position using the factory ball clamp. Install the hanger into the rubber isolator. (See Fig. 4) Do not tighten the clamp.
2. Place a clamp on the inlet of the **Muffler Assembly** and insert into the **Front Pipe Assembly** and insert hanger into rubber isolators. Use a muffler stand or an assistant to hold into position. (See Fig. 5) Do not tighten the clamp.
3. Place clamp over the expanded end of **Over Axle Pipe** inlet. Insert into **Muffler Assembly** outlet. Do not tighten the clamp.
4. Place clamp over the expanded end of the R/H Tail Pipe Assembly. Insert into **Muffler Assembly** outlet and insert hanger into rubber isolator. (See Fig. 6)
5. Install **Bracket Hanger Assembly** to left-side using provided hardware. (See Fig. 7) Do not tighten the clamp.
6. Install the supplied **Heat Shield Reflex Wrap** to the brake line over axle. (See Fig. 8)
7. Check your exhaust system for proper clearance under the vehicle and also for tip alignment. Tighten clamp nut 35 ft. lbs.
8. Before starting your vehicle, make sure to check all wires, hoses, brake lines, body parts and tires for safe clearance from the exhaust system.
9. Start vehicle and check for any leaks. If any leaks are found, determine cause such as loose or incorrectly positioned clamp and repair as necessary.

Note: *When you first start your vehicle after the installation of your new Borla Performance Exhaust System, there may be some smoke and fumes coming from the system. This is a protective oil based coating used in the manufacturing of mandrel bent performance exhaust tubing. This is not a problem and will disappear within a very short period of time after the exhaust has reached normal operating temperatures.*

Warning: *Use extreme caution during installation. Torque all fasteners according to manufacturer's torque values and tightening sequence. DO NOT use air impact tools to tighten fasteners on Borla Performance Exhaust Systems. Use of such tools may result in bent flanges or gasket contact areas leading to exhaust leaks.*

