

Exhaust System Installation for BMW 328i Sedan PN-140505



These instructions have been written to help you with the installation of your Borla [Performance Exhaust System](#). Please read this document completely before beginning the installation of your system.

Please compare the parts in the box with the bill of materials provided to assure that you have all the parts necessary for this installation.

Thank you for purchasing a Borla Performance Exhaust System.

This Borla Performance Cat-Back™ Exhaust System (Part number 140505) is designed for the E90 BMW 328i Sedan equipped with a 3.0L 6-cylinder engine, automatic or manual transmissions.

Borla Performance Industries recommends that an exhaust shop or professional after market parts installer perform the installation of this system. However, if you decide to perform the installation on your own it is recommended that two people are used. This installation should not be performed by one person due to the risk of injury. Ensure the installers use all under car safety precautions including eye protection.

Please take time to read and understand the following...

By installing your Borla Performance Exhaust System, you indicate that you have read this document and you agree with the terms stated below.

It is the responsibility of the purchaser to follow all installation instruction guidelines and safety procedures supplied with your Borla Performance Exhaust System

Borla Performance Industries assumes no responsibility for damages occurring from misuse, abuse, improper installation, improper operation, lack of responsible care, or all previously stated reasons resulting from incompatibility with other manufacturer's products and/or systems.

Included with your Borla Performance Exhaust System is a warranty card. Please read it carefully before you begin any work on your vehicle. If you should have any questions regarding our warranty policy, installation, or any other matter pertaining to your new Borla Performance Exhaust System, please give us a call at the number provided on the warranty card.

Minimum Required Tool List:

TOOLS:

- 1 3/8" Drive Ratchet
- 2 3/8" Drive Extension 3"
- 3 13mm Socket
- 5 Pry Bar

SHOP SUPPLIES:

- 1 Spray Lubricant

Borla Performance Cat-Back™ Bill of Materials

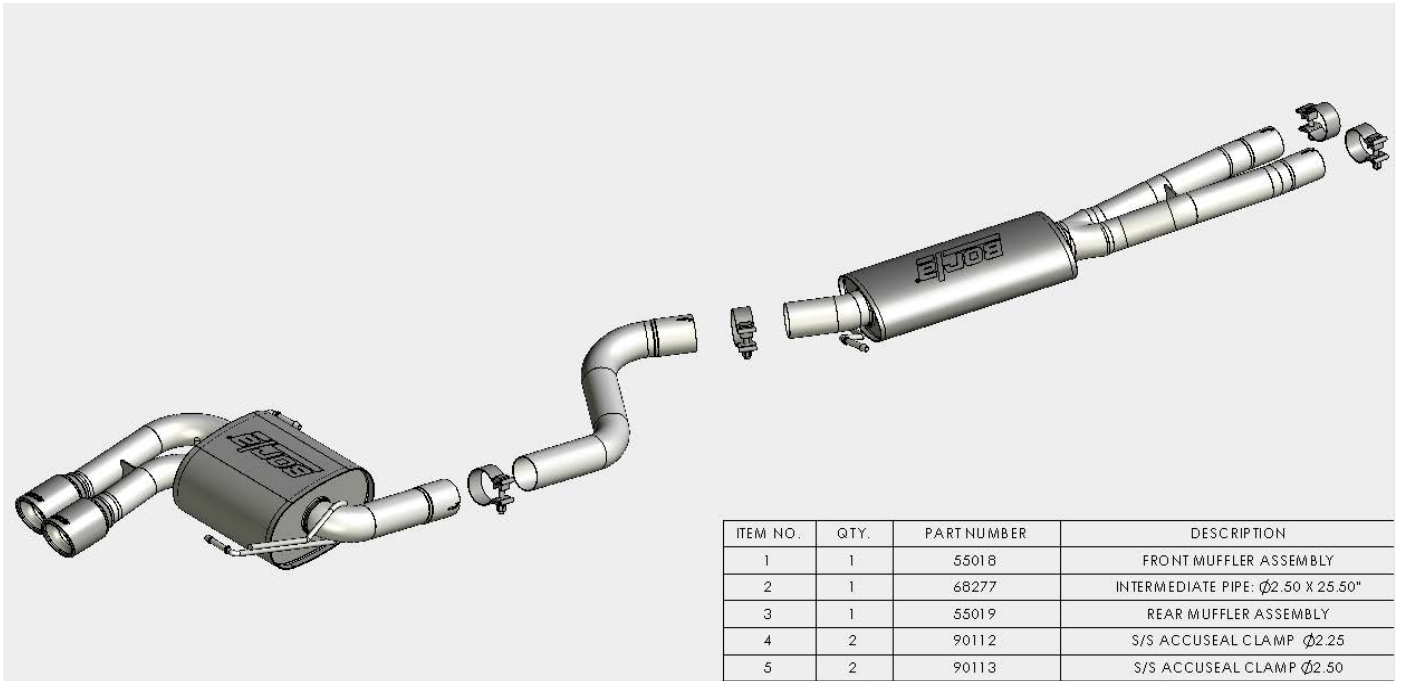

ITEM NO.	QTY.	PART NUMBER	DESCRIPTION
1	1	55018	FRONT MUFFLER ASSEMBLY
2	1	68277	INTERMEDIATE PIPE: Ø2.50 X 25.50"
3	1	55019	REAR MUFFLER ASSEMBLY
4	2	90112	S/S ACCUSEAL CLAMP Ø2.25
5	2	90113	S/S ACCUSEAL CLAMP Ø2.50

Caution!!! *Never work on a hot exhaust system. Serious injury in the form of burns can result* If the vehicle has been in use and the exhaust system is hot, allow vehicle to cool for at least 1 hour. Always wear eye protection when working under any vehicle.

Note: It is our recommendation that you use a hoist or hydraulic lift to facilitate the installation of your new Borla Performance Cat-Back™ Exhaust System.

Taking all under car safety precautions, lift the vehicle using a hoist or hydraulic lift. Once this has been done, you may begin the removal of your old exhaust system from your vehicle.

Note: *Before removing the original exhaust system from your vehicle, please compare the parts you have received with the bill of materials provided on the previous page to assure that you have all the parts necessary for the installation of your new Borla Performance Cat-Back™ Exhaust System.*

Original Exhaust System Removal

Note: With a used vehicle, we suggest a penetrating spray lubricant to be applied liberally to all exhaust fasteners and allowing a significant period of time for the chemical to lubricate the threads before attempting to disassemble.

1. Remove cross-brace. Mark and carefully cut pipe using metal-equipped cutting saw 5-1/2" behind factory catalytic converters. (See Figs. 1A & 1B)
2. Using a muffler stand or an additional person to hold the muffler assembly up into position, slide the (3) hangars out of the rubber isolators and remove the system from the rear. Original rubber isolators are used in the installation of your new exhaust system.
3. De-burr edges of pipe.
4. Reinstall cross brace and tighten hardware.
5. Exhaust system removed. (Figure 3)

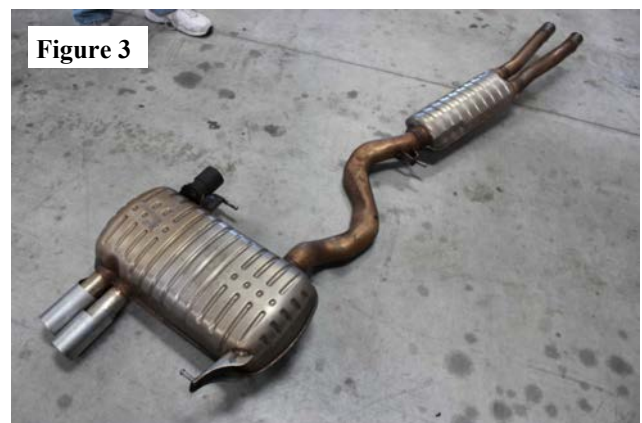
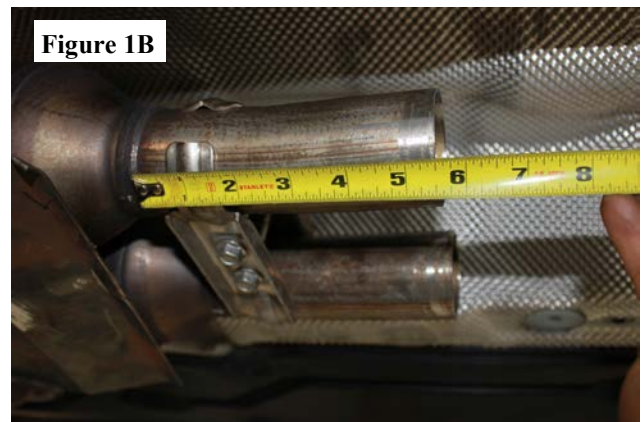
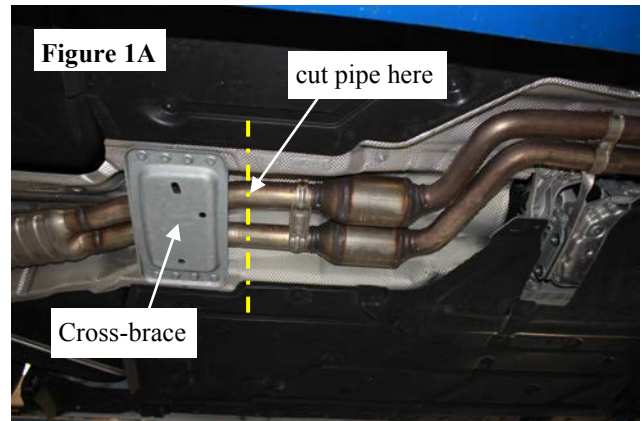

Borla Performance Cat-Back™ Exhaust System Installation

1. Place the Accuseal clamps over the Front Muffler Assembly pipes. Slide pipes over the newly cut pipe. Insert hangers into rubber isolators. (See Fig.4) DO NOT tighten these bolts.
2. Place the Accuseal clamp over the Rear Muffler Assembly and slide this pipe over the front muffler assembly. Insert hangers into rubber isolators. (See Fig. 5)

NOTE: When properly clamped, the Accuseal pipe closes with interlocking notches creating a proper seal.

IMPORTANT: Verify the clamp bolt is positioned between the notch or the pipe will distort or ovalize in shape. This may lead to improper seal and exhaust leakage.

3. Check your exhaust system for proper clearance under the vehicle and also for tip alignment. Once position has been determined to be correct, tighten the Accuseal™ clamp 32-35 ft. lbs. Tighten the OE clamp bolts.
4. Before starting your vehicle, make sure to check all wires, hoses, brake lines, body parts and tires for safe clearance from the exhaust system.
5. Start vehicle and check for any leaks. If any leaks are found, determine cause (such as loose or incorrectly positioned clamp) and repair as necessary.

Note: When you first start your vehicle after the installation of your new Borla Performance Exhaust System, there may be some smoke and fumes coming from the system. This is a protective oil based coating used in the manufacturing of mandrel bent performance exhaust tubing. This is not a problem and will disappear within a very short period of time after the exhaust has reached normal operating temperatures.

Congratulations!!! You have completed the installation of the world famous Borla Performance Stainless Steel Exhaust System.



Figure 4



Figure 5

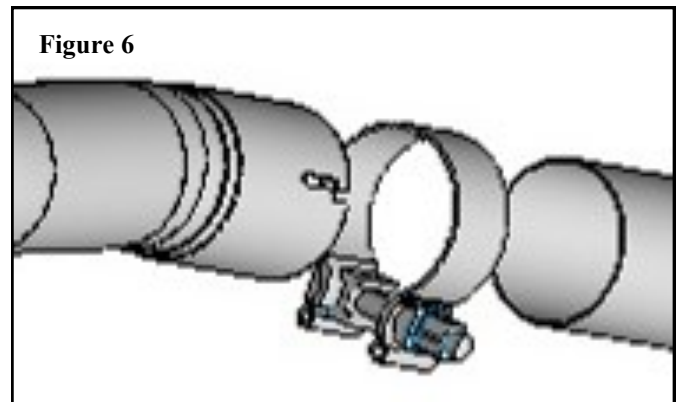

Figure 6



Figure 7