

Toyota FJ Cruiser Exhaust System Installation



Precision manufactured using aircraft quality T-304 stainless steel; this system is designed to endure years of heavy use. Installing a Borla Performance Exhaust System on your vehicle will eliminate the restrictive design of the stock exhaust, allowing your engine to discharge exhaust gas easier. The result is more horsepower and torque, longer engine life, and a distinctive throaty growl- all this, with easy bolt-on installation. These installation instructions have been written to help you in the installation of your Borla Performance Exhaust System. Please read it completely before installing your system.

Thank you for purchasing a Borla Performance Cat-Back™ Exhaust System.

Borla Performance Cat-Back Exhaust Systems (PN-140200, 140405) are designed for the Toyota FJ Cruiser equipped with a 4.0L V6 engine, 2 or 4-wheel drive, automatic or manual transmissions.

Borla Performance Industries recommends that an exhaust shop or professional after market parts installer, who has all the necessary equipment, tools and experienced personnel needed for proper installation, should perform the installation of this system. However, if you decide to perform the installation, we recommend someone should help you. Ensure the installer uses all under car safety precautions including eye protection.

Please take time to read and understand the following...

By installing your Borla Performance Exhaust System, you indicate that you have read this document and you agree with the terms stated below.

It is the responsibility of the purchaser to follow all installation instruction guidelines and safety procedures supplied with your Borla Performance Exhaust System

Borla Performance Industries assumes no responsibility for damages occurring from misuse, abuse, improper installation, improper operation, lack of responsible care, or all previously stated reasons resulting from incompatibility with other manufacturer's products and/or systems.

Included with your Borla Performance Exhaust System is a warranty card. Please read it carefully before you begin any work on your vehicle. If you should have any questions regarding our warranty policy, installation, or any other matter pertaining to your new Borla Performance Exhaust System, please give us a call at the number provided on the warranty card.

Minimum Required Tool List:

TOOLS:

- 1 3/8" Drive Ratchet
- 2 3/8" Drive Extension 3"
- 3 15mm Socket
- 4 Pry Bar

SHOP SUPPLIES:

- 1 Spray Lubricant

Borla Performance Cat-Back™ Bill of Materials

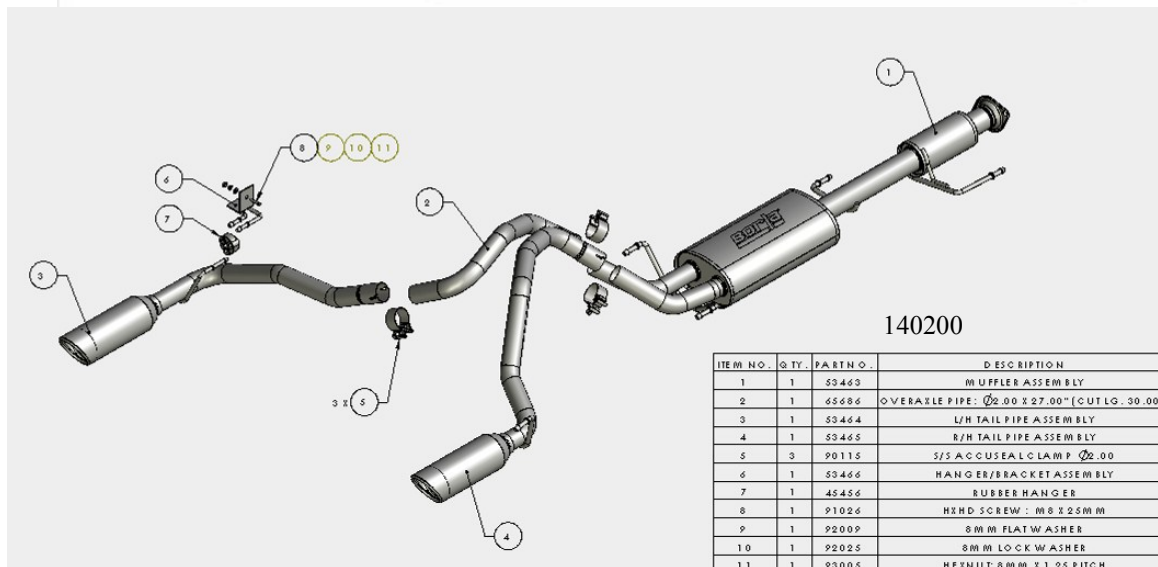

ITEM NO.	QTY.	PART NO.	DESCRIPTION
1	1	53463	MUFFLER ASSEMBLY
2	1	65686	OVERAXLE PIPE: Ø2.00 X 27.00" (CUT LG. 30.00")
3	1	53464	L/H TAIL PIPE ASSEMBLY
4	1	53465	R/H TAIL PIPE ASSEMBLY
5	3	90115	S/S ACCUSEAL CLAMP Ø2.00
6	1	53466	HANGER/BRACKET ASSEMBLY
7	1	45456	RUBBER HANGER
8	1	91026	HXHD SCREW : M8 X 25MM
9	1	P2009	8MM FLAT WASHER
10	1	P2025	8MM LOCK WASHER
11	1	P3005	HEX NUT: 8MM X 1.25 PITCH

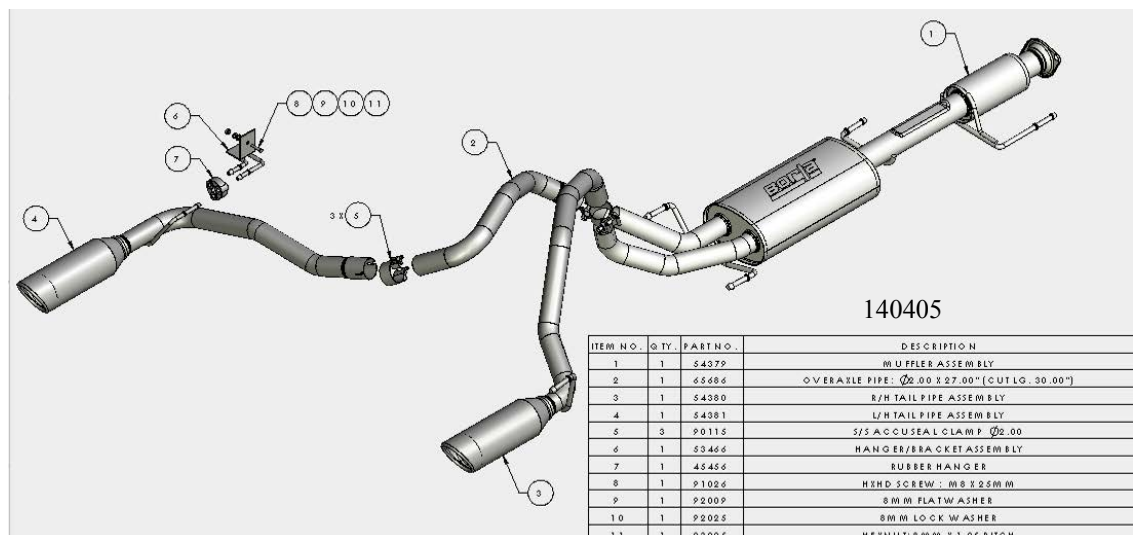

ITEM NO.	QTY.	PART NO.	DESCRIPTION
1	1	54379	MUFFLER ASSEMBLY
2	1	65686	OVERAXLE PIPE: Ø2.00 X 27.00" (CUT LG. 30.00")
3	1	54380	R/H TAIL PIPE ASSEMBLY
4	1	54381	L/H TAIL PIPE ASSEMBLY
5	3	90115	S/S ACCUSEAL CLAMP Ø2.00
6	1	53466	HANGER/BRACKET ASSEMBLY
7	1	45456	RUBBER HANGER
8	1	91026	HXHD SCREW : M8 X 25MM
9	1	P2009	8MM FLAT WASHER
10	1	P2025	8MM LOCK WASHER
11	1	P3005	HEX NUT: 8MM X 1.25 PITCH

Caution!!! Never work on a hot exhaust system. Serious injury in the form of burns can result If the vehicle has been in use and the exhaust system is hot, allow vehicle to cool for at least 1 hour. Always wear eye protection when working under any vehicle.

Note: It is our recommendation that you use a hoist or hydraulic lift to facilitate the installation of your new Borla Performance Cat-Back™ Exhaust System.

Taking all under car safety precautions, lift the vehicle using a hoist or hydraulic lift. Once this has been done, you may begin the removal of your old exhaust system from your vehicle.

Note: Before removing the original exhaust system from your vehicle, please compare the parts you have received with the bill of materials provided on the previous page to assure that you have all the parts necessary for the installation of your new Borla Performance Cat-Back™ Exhaust System.

Original Exhaust System Removal

Note: With a used vehicle, we suggest a penetrating spray lubricant to be applied liberally to all exhaust fasteners and allowing a significant period of time for the chemical to lubricate the threads before attempting to disassemble.

1. For an easier time during the removal of your original exhaust and the installation of your new exhaust, remove the spare tire as recommended by your vehicles manual.
2. Unbolt the flange shown in figure 1 located just behind the muffler assembly.
3. Lubricate all the hangers and rubber isolators.
4. Using a muffler stand or an additional person to hold the tail pipe in position, remove the hanger from the rubber isolator and remove the tail pipe assembly shown in figure 2.
5. Unbolt the flange shown in figure 3 located behind the catalytic converters. Place the hardware to the side for use during the installation of your new exhaust system.
6. Using a muffler stand or an additional person to hold the muffler assembly in position, remove the hangers from the rubber isolators and remove the muffler assembly from the vehicle.

Warning: Use extreme caution during installation. Torque all fasteners according to manufacturer's torque values and tightening sequence. DO NOT use air impact tools to tighten fasteners on Borla Performance Exhaust Systems. Use of such tools may result in bent flanges or gasket contact areas leading to exhaust leaks.



Figure 1



Figure 2



Figure 3

Borla Performance Cat-Back™ Exhaust System Installation

1. Using the original hardware, place the muffler assembly into position as shown in figure 4. Hand tighten the hardware for now.
2. Using the hardware provided, install the hanger/bracket assembly on the driver side frame rail, just behind the rear tire as shown in figure 5. Install the rubber isolator onto the hanger/bracket assembly.
3. Place a clamp over the expanded end of the right tail pipe assembly and set it up into position as shown in figure 6 making sure to install the hanger into the rubber isolator.
4. Place a clamp over the expanded end of the over axle pipe and set it into position as shown in figure 7 making sure to install the hangers into the rubber isolators. **Do Not** tighten the clamp.
5. Place a clamp over the expanded end of the left tail pipe assembly and set it into position as shown in figure 8 making sure to install the hanger into the rubber isolator. **Do Not** tighten the clamp.
6. Check your exhaust system for proper clearance under the vehicle and also for tip alignment.
7. Once position has been determined to be correct, tighten the Accuseal™ clamps to 32-35 ft. lbs. and tighten the flange hardware to 18-22 ft. lbs.
8. Before starting your vehicle, make sure to check all wires, hoses, brake lines, body parts and tires for safe clearance from the exhaust system.
9. Start vehicle and check for any leaks. If any leaks are found, determine cause (such as loose hardware or incorrectly posi-

Note: When you first start your vehicle after the installation of your new Borla Performance Exhaust System, there may be some smoke and fumes coming from the system. This is a protective oil based coating used in the manufacturing of mandrel bent performance exhaust tubing. This is not a problem and will disappear within a very short period of time after the exhaust has reached normal operating temperatures.



Figure 4



Figure 5



Figure 6



Figure 7



Figure 8