

Cat-Back[™] Exhaust Installation 140400



These instructions have been written to help you with the installation of your Borla Performance Exhaust System. Please read this document completely before beginning the installation of your system.

Please compare the parts in the box with the bill of materials provided to assure that you have all the parts necessary for this installation.

Thank you for purchasing a Borla Performance Cat-Back[™] Exhaust System.

This Borla Performance Cat-Back[™] Exhaust System (Part number 140400) is designed for the Ford Focus, 2.0L engine, FWD drive and automatic transmission.

Borla Performance Industries recommends that an exhaust shop or professional after market parts installer perform the installation of this system. However, if you decide to perform the installation on your own it is recommended that two people are used. This installation should not be performed by one person due to the risk of injury. Ensure the installers use all under car safety precautions including eye protection.

Please take time to read and understand the following...

By installing your Borla Performance Exhaust System, you indicate that you have read this document and you agree with the terms stated below.

It is the responsibility of the purchaser to follow all installation instruction guidelines and safety procedures supplied with your Borla Performance Exhaust System

Borla Performance Industries assumes no responsibility for damages occurring from misuse, abuse, improper installation, improper operation, lack of responsible care, or all previously stated reasons resulting from incompatibility with other manufacturer's products and/or systems.

Included with your Borla Performance Exhaust System is a warranty card. Please read it carefully before you begin any work on your vehicle. If you should have any questions regarding our warranty policy, installation, or any other matter pertaining to your new Borla Performance Exhaust System, please give us a call at the number provided on the warranty card.

Minimum Required Tool List:

TOOLS:

1. 3/8" Drive Ratchet
2. 3/8" Drive Extension 3"
3. 13mm, 10mm Deep Well Sockets
4. Pry Bar
5. Metal-cutting blade sawsall

SHOP SUPPLIES:

- 1 Spray Lubricant

Borla Performance Cat-Back™ Bill of Materials

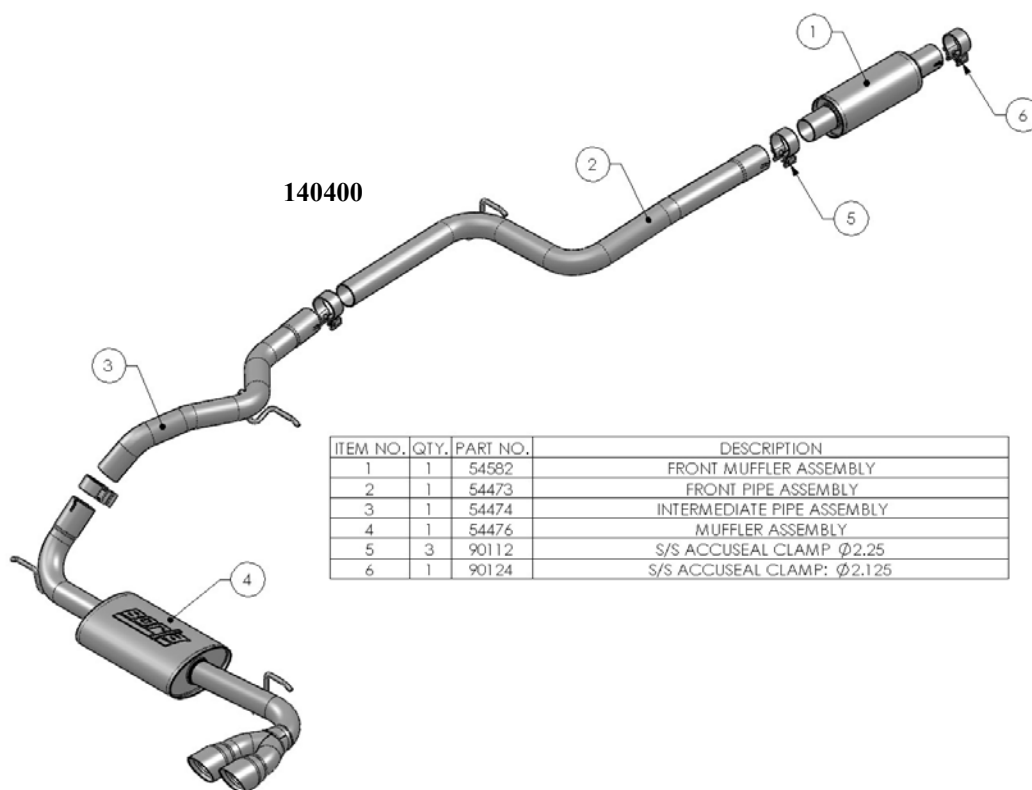

ITEM NO.	QTY.	PART NO.	DESCRIPTION
1	1	54582	FRONT MUFFLER ASSEMBLY
2	1	54473	FRONT PIPE ASSEMBLY
3	1	54474	INTERMEDIATE PIPE ASSEMBLY
4	1	54476	MUFFLER ASSEMBLY
5	3	90112	S/S ACCUSEAL CLAMP Ø2.25
6	1	90124	S/S ACCUSEAL CLAMP: Ø2.125

Caution!!! *Never work on a hot exhaust system. Serious injury in the form of burns can result* If the vehicle has been in use and the exhaust system is hot, allow vehicle to cool for at least 1 hour. Always wear eye protection when working under any vehicle.

Note: It is our recommendation that you use a hoist or hydraulic lift to facilitate the installation of your new Borla Performance Cat-Back™ Exhaust System.

Taking all under car safety precautions, lift the vehicle using a hoist or hydraulic lift. Once this has been done, you may begin the removal of your old exhaust system from your vehicle.

Note: Before removing the original exhaust system from your vehicle, please compare the parts you have received with the bill of materials provided on the previous page to assure that you have all the parts necessary for the installation of your new Borla Performance Cat-Back™ Exhaust System.

Original Exhaust System Removal

Note: With a used vehicle, we suggest a penetrating spray lubricant to be applied liberally to all exhaust fasteners and allowing a significant period of time for the chemical to lubricate the threads before attempting to disassemble.

1. Stock exhaust needs to be cut in (2) places for removal. Using a metal-cutting-blade saw, make a cut the stock exhaust pipe in front of the rear axle making sure not to damage vehicle. (See Fig.1)
2. Remove hangers from rubber isolators to remove muffler. (See Fig.2)
3. Measure and mark a cut-line 3-1/2" behind the catalytic converter. (See Fig. 3)
4. Using a metal-cutting-blade saw, cut the pipe at this mark making sure not to damage vehicle. De-burr the newly cut pipe. (See Fig.4)
5. Using a muffler stand or an additional person to hold the exhaust system up in place, remove the hangers from the rubber isolators and remove the exhaust system from the vehicle.
6. Carefully remove the remaining exhaust from the vehicle. (See Fig. 5)

Warning: Use extreme caution during installation. Torque all fasteners according to manufacturer's torque values and tightening sequence. **DO NOT** use air impact tools to tighten fasteners on Borla Performance Exhaust Systems. Use of such tools may result in bent flanges or gasket contact areas leading to exhaust leaks.

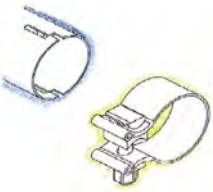

Borla Performance Cat-Back™ Exhaust System Installation

1. Refer to assembly drawing on page 2 and orient components as shown. (See Fig. 6)
 2. Insert Intermediate Pipe Assembly into position over the rear axle as shown (hint: install pipe in front of axle). Insert hangers into rubber isolators. (See Fig. 7)
 3. Place a clamp over the expanded-end of the Muffler Assembly and insert pipe into Intermediate Pipe Assembly. Insert hangers in rubber isolators. (See Fig. 8)
 4. Place a clamp over the expanded end of the Intermediate Pipe Assembly. Insert the Front Pipe Assembly inlet into the Intermediate Pipe Assembly. Place a clamp over expanded end of Front Muffler Assembly and insert into Front Pipe. Place a clamp over the other end of Front Muffler Assembly and slip over stock cut pipe. (See Fig. 9)
 5. Re-install cross-brace using original hardware. (See Fig. 10)
 6. Check your exhaust system for proper clearance under the vehicle and also for tip alignment.
 7. Once position has been determined to be correct, tighten the Accuseal clamps to 32-35 ft. lbs.
IMPORTANT: Make sure the clamp bolt is positioned between the pipe notches NOT over the pipe notches.
- 
6. Before starting your vehicle, make sure to check all wires, hoses, brake lines, body parts and tires for safe clearance from the exhaust system.
 7. Start vehicle and check for any leaks. If any leaks are found, determine cause (such as loose or incorrectly positioned clamp) and repair as necessary.

Note: When you first start your vehicle after the installation of your new Borla Performance Exhaust System, there may be some smoke and fumes coming from the system. This is a protective oil based coating used in the manufacturing of mandrel bent performance exhaust tubing. This is not a problem and will disappear within a very short period of time after the exhaust has reached normal operating temperature.

Congratulations!!! You have completed the installation of the world famous Borla Performance Stainless Steel Exhaust System.

