

## Installation for Ford Mustang Convertible PN's 11938, 11939



**\*\*\*\*\* Please compare the parts in the box with the bill of materials provided \*\*\*\*\*  
to assure that you have all the parts necessary for this installation.**

These instructions have been written to help you with the installation of your Borla Performance Exhaust System. Please read this document completely before beginning the installation of your system.

### Thank you for purchasing a Borla Performance Axle Back System.

**Borla Performance Axle Back Exhaust Systems (PN's 11938, 11939) are designed for the Ford Mustang CONVERTIBLE equipped with the 2.3L 4-Cyl EcoBoost engine & 3.7L V6 engine, automatic or manual transmissions.**

Borla Performance Industries recommends that an exhaust shop or professional after market parts installer, who has all the necessary equipment, tools and experienced personnel needed for proper installation, should perform the installation of this system. However, if you decide to perform the installation, we recommend someone should help you. Ensure the installer uses all under car safety precautions including eye protection.

*Please take time to read and understand the following...*

By installing your Borla Performance Exhaust System, you indicate that you have read this document and you agree with the terms stated below.

It is the responsibility of the purchaser to follow all installation instruction guidelines and safety procedures supplied with your Borla Performance Exhaust System.

Borla Performance Industries assumes no responsibility for damages occurring from misuse, abuse, improper installation, improper operation, lack of responsible care, or all previously stated reasons resulting from incompatibility with other manufacturer's products and/or systems.

Included with your Borla Performance Exhaust System is a warranty card. Please read it carefully before you begin any work on your vehicle. If you should have any questions regarding our warranty policy, installation, or any other matter pertaining to your new Performance Exhaust System, please give us a call at the number provided on the warranty card.

**Minimum Required Tool List:**

**TOOLS:**

1. 3/8” Drive Ratchet
2. 3/8” Drive Extension 3”
3. 15mm Deep Well Socket
4. 13mm Socket
5. Metal Cutting Blade Saw
6. Pry Bar

**SHOP SUPPLIES:**

- 1 Spray Lubricant

**Borla Performance - Bill of Materials**

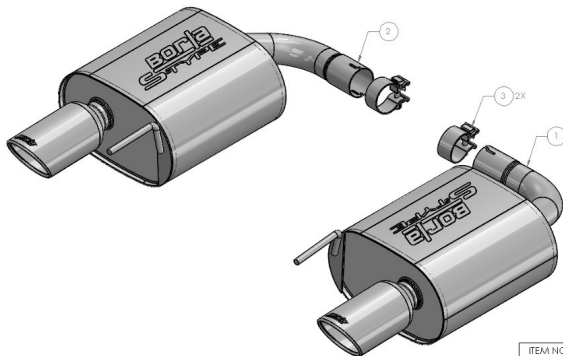

**11938**

ITEM NO.	QTY.	PART NUMBER	DESCRIPTION
1	1	56410	R/H MUFFLER ASSEMBLY
2	1	56411	L/H MUFFLER ASSEMBLY
3	2	90112	2.25 ACCUSEAL CLAMP

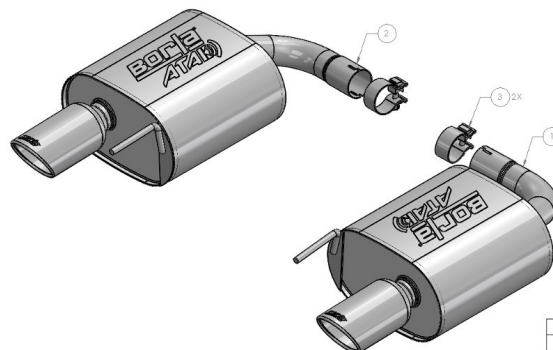

**11939**

ITEM NO.	QTY.	PART NUMBER	DESCRIPTION
1	1	56412	R/H MUFFLER ASSEMBLY
2	1	56413	L/H MUFFLER ASSEMBLY
3	2	90112	2.25 ACCUSEAL CLAMP

**Caution!!!** *Never work on a hot exhaust system. Serious injury in the form of burns can result if the vehicle has been in use and the exhaust system is hot, allow vehicle to cool for at least 1 hour. Always wear eye protection when working under any vehicle.*

**Note:** *It is our recommendation that you use a hoist or hydraulic lift to facilitate the installation of your new Borla Performance Exhaust System.*

**Taking all under car safety precautions, lift the vehicle using a hoist or hydraulic lift. Once this has been done, you may begin the removal of your old exhaust system from your vehicle.**

**Note:** *Before removing the original exhaust system from your vehicle, please compare the parts you have received with the bill of materials provided on the previous page to assure that you have all the parts necessary for the installation of your new Borla Performance Exhaust System.*

**Note:** *With a used vehicle, we suggest a penetrating spray lubricant to be applied liberally to all exhaust fasteners and allowing a significant period of time for the chemical to lubricate the threads before attempting to disassemble.*

**\*\*\*\*\* MUSTANG GT \*\*\*\*\***  
**CONVERTIBLE ONLY**

**Chassis Stiffener Removal**

1. Remove on (2) sections the Chassis Stiffener, starting with right-side side. Place the hardware to the side for re-installation. (See Fig. 1& 2)
2. Repeat STEP-1 for the left-side side. (See Fig. 3 & 4)
3. Using a muffler stand or a additional person, to hold the Chassis Stiffener into position carefully remove from the vehicle.

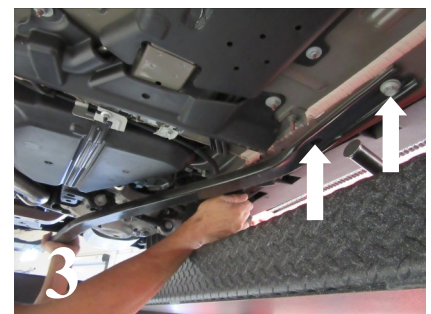
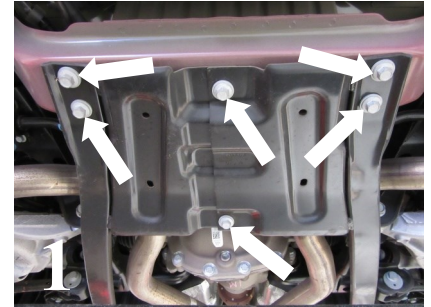

**Caution!!!** *Never work on a hot exhaust system. Serious injury in the form of burns can result if the vehicle has been in use and the exhaust system is hot, allow vehicle to cool for at least 1 hour. Always wear eye protection when working under any vehicle.*

*Note: It is our recommendation that you use a hoist or hydraulic lift to facilitate the installation of your new Borla Performance Exhaust System.*

*Taking all under car safety precautions, lift the vehicle using a hoist or hydraulic lift. Once this has been done, you may begin the removal of your old exhaust system from your vehicle.*

*Note: Before removing the original exhaust system from your vehicle, please compare the parts you have received with the bill of materials provided on the previous page to assure that you have all the parts necessary for the installation of your new Borla Performance Exhaust System.*

*Note: With a used vehicle, we suggest a penetrating spray lubricant to be applied liberally to all exhaust fasteners and allowing a significant period of time for the chemical to lubricate the threads before attempting to disassemble.*

## Original Exhaust Removal

1. The factory under-axle pipe must be cut and rear muffler removed.
2. Starting on right-side under-axle pipe, measure and mark a perpendicular **cut-line** (indicated in green) 2" from pipe bend (indicated in white). Use a metal cutting bladed saw, carefully cut this right-side pipe at the **cut line**. (See Fig. 5)
3. Remove hanger from rubber isolator and carefully remove the right-side muffler from the vehicle. (See Fig. 6 & 7)
4. Repeat STEP-2 to mark left-side **cut-line**. Cut the left side pipe and remove left-side muffler from vehicle.
5. Clean the under-axle pipes and de-burr the edges using a file or rotary grinder.
6. Original system removed. (See Fig. 8)

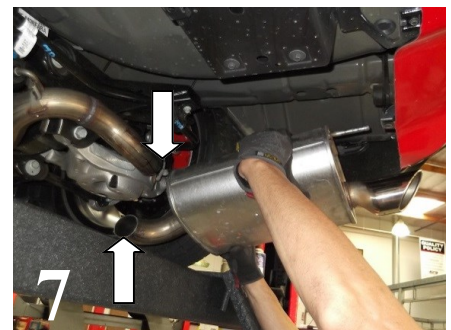
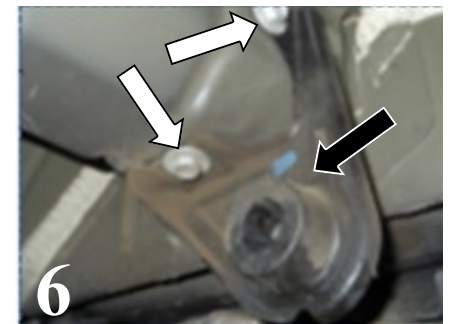
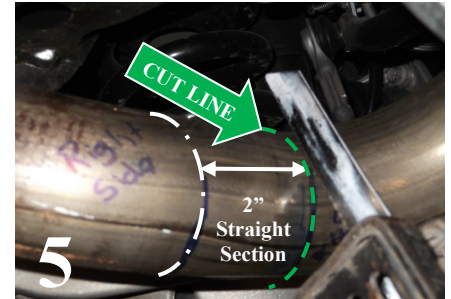

## Borla Performance Axle Back System Installation

1. Orient components referencing page-2 drawings.
2. Beginning with the **L/H Muffler Assembly**, place a clamp over the inlet tube and insert (2) hangers into the rubber isolator. Insert **L/H Muffler Assembly** inlet tube over the (cut) under-axle pipe. (See Fig. 11 & 12) Do not Tighten the Clamp.
3. Repeat Step 1 for the installation of the **R/H Muffler Assembly**.
4. Using the original hardware, RE-INSTALL the chassis stiffener to vehicle.
5. Check your exhaust system for proper clearance under the vehicle and also for tip alignment. Orient position of bolt (on supplied clamps) between (not over) pipe notches and tighten to 35 ft. lbs. torque. (See Fig. 13)
6. Align tips and tighten hardware. Loosen clamps to rotate or slide pipe for better alignment. (See Fig. 14)
7. Before starting your vehicle, make sure to check all wires, hoses, brake lines, body parts and tires for safe clearance from the exhaust system.
8. Start vehicle and check for any leaks. If any leaks are found, determine cause (such as loose or incorrectly positioned clamp) and repair as necessary.

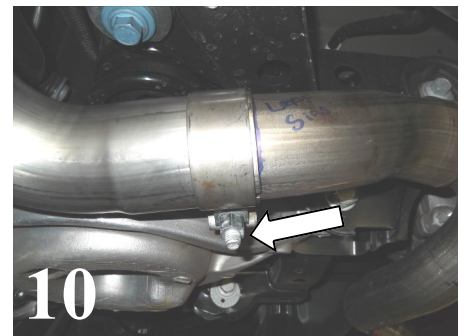

**WARNING:** Use extreme caution during installation. Torque all fasteners according to manufacturer's torque values and tightening sequence. **DO NOT** use air impact tools to tighten fasteners on Borla Performance Exhaust Systems. Use of such tools may result in bent flanges or gasket contact areas leading to exhaust leaks.

**NOTE:** When you first start your vehicle after the installation of your new Borla Performance Exhaust System, there may be some smoke and fumes coming from the system. This is a protective oil based coating used in the manufacturing of mandrel bent performance exhaust tubing. This is not a problem and will disappear within a very short period of time after the exhaust has reached normal operating temperatures.