

Installation for Honda Accord PN 11840, 11853



These instructions have been written to help you with the installation of your Borla [Performance Exhaust System](#). Please read this document completely before beginning the installation of your system.

Please compare the parts in the box with the bill of materials provided to assure that you have all the parts necessary for this installation.

Thank you for purchasing a Borla Performance Exhaust System.

Borla Performance Rear Section Exhaust System (11840) is designed for the Honda Accord Sedan, 3.5L 6-cylinder engine FWD/automatic transmission and Sport Model with 2.4L 4-cylinder engine FWD/automatic transmission. Does Not fit 2.4L 4-cylinder engine with single exit.

Borla Performance Rear Section Exhaust System (11853) is designed for the Honda Accord Coupe, 3.5L 6-cylinder engine FWD, automatic/manual transmissions.

Borla Performance Industries recommends that an exhaust shop or professional after market parts installer perform the installation of this system. However, if you decide to perform the installation on your own it is recommended that two people are used. This installation should not be performed by one person due to the risk of injury. Ensure the installers use all under car safety precautions including eye protection.

Please take time to read and understand the following...

By installing your Borla Performance Exhaust System, you indicate that you have read this document and you agree with the terms stated below.

It is the responsibility of the purchaser to follow all installation instruction guidelines and safety procedures supplied with your Borla Performance Exhaust System

Borla Performance Industries assumes no responsibility for damages occurring from misuse, abuse, improper installation, improper operation, lack of responsible care, or all previously stated reasons resulting from incompatibility with other manufacturer's products and/or systems.

Included with your Borla Performance Exhaust System is a warranty card. Please read it carefully before you begin any work on your vehicle. If you should have any questions regarding our warranty policy, installation, or any other matter pertaining to your

Minimum Required Tool List:

TOOLS:

1. 3/8" Drive Ratchet
2. 3/8" Drive Extension 3"
3. 14mm, 15mm Deep Well Socket
4. Pry Bar

SHOP SUPPLIES:

- 1 Spray Lubricant

Borla Performance - Bill of Materials

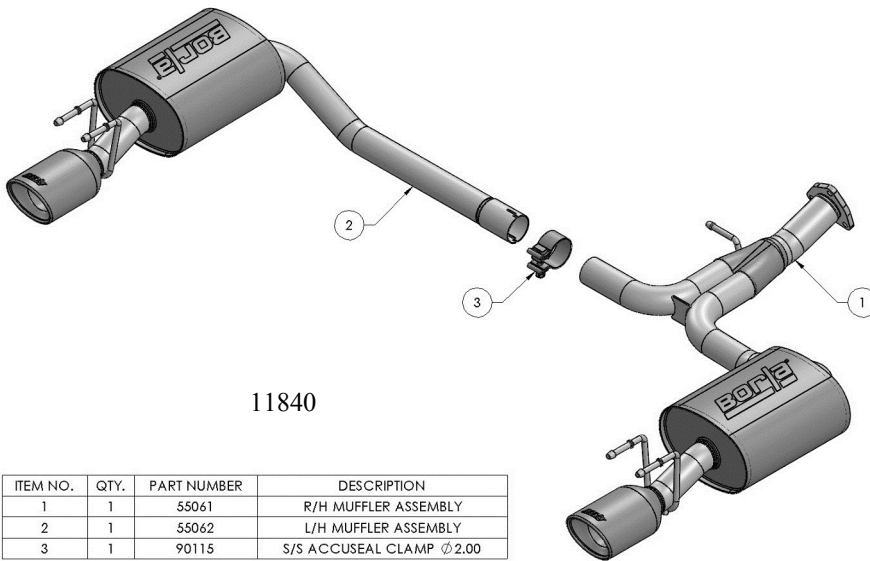

11840

ITEM NO.	QTY.	PART NUMBER	DESCRIPTION
1	1	55061	R/H MUFFLER ASSEMBLY
2	1	55062	L/H MUFFLER ASSEMBLY
3	1	90115	S/S ACCUSEAL CLAMP \varnothing 2.00

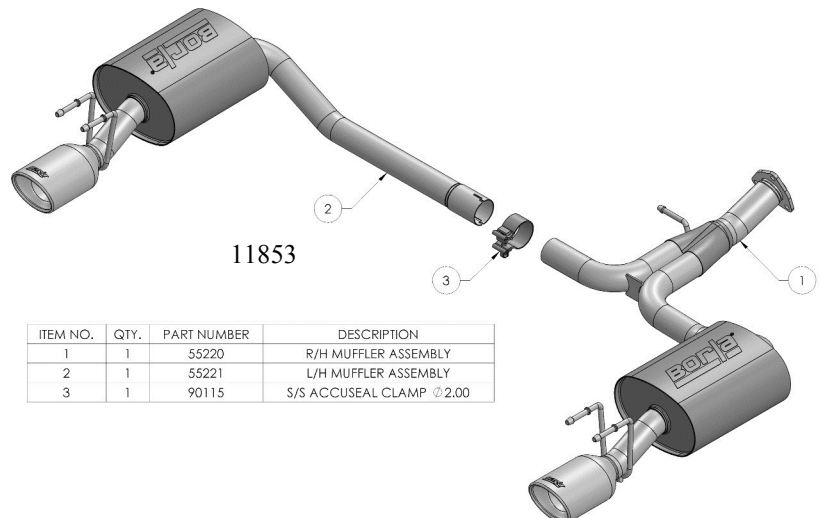

11853

ITEM NO.	QTY.	PART NUMBER	DESCRIPTION
1	1	55220	R/H MUFFLER ASSEMBLY
2	1	55221	L/H MUFFLER ASSEMBLY
3	1	90115	S/S ACCUSEAL CLAMP \varnothing 2.00

Caution!!! *Never work on a hot exhaust system. Serious injury in the form of burns can result* If the vehicle has been in use and the exhaust system is hot, allow vehicle to cool for at least 1 hour. Always wear eye protection when working under any vehicle.

Note: It is our recommendation that you use a hoist or hydraulic lift to facilitate the installation of your new Borla Performance Rear Section Exhaust System.

Taking all under car safety precautions, lift the vehicle using a hoist or hydraulic lift. Once this has been done, you may begin the removal of your old exhaust system from your vehicle.

Note: Before removing the original exhaust system from your vehicle, please compare the parts you have received with the bill of materials provided on the previous page to assure that you have all the parts necessary for the installation of your new Borla Performance Rear Section Exhaust System.

Original Exhaust System Removal

Note: With a used vehicle, we suggest a penetrating spray lubricant to be applied liberally to all exhaust fasteners and allowing a significant period of time for the chemical to lubricate the threads before attempting to disassemble.

1. Lubricate all the hangers and rubber isolators.
2. Remove rear muffler flange hardware. **Note: Keep factory hardware and sealing gasket for reinstallation.** (See Fig.1)
3. Carefully slide and remove rubber isolators from hangars and remove rear muffler assembly. (See Figs. 2 & 3)
4. Removed factory exhaust. (See Fig. 4)
5. Remove factory metal sealing ring for reuse and installation on your new exhaust system.

Warning: Use extreme caution during installation. Torque all fasteners according to manufacturer's torque values and tightening sequence. **DO NOT** use air impact tools to tighten fasteners on Borla Performance Exhaust Systems. Use of such tools may result in bent flanges or gasket contact areas leading to exhaust leaks.

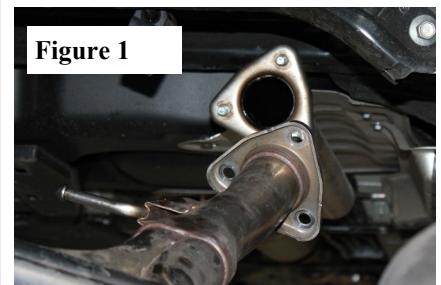

Caution!!! *Never work on a hot exhaust system. Serious injury in the form of burns can result* If the vehicle has been in use and the exhaust system is hot, allow vehicle to cool for at least 1 hour. Always wear eye protection when working under any vehicle.

Note: It is our recommendation that you use a hoist or hydraulic lift to facilitate the installation of your new Borla Performance Rear Section Exhaust System.

Taking all under car safety precautions, lift the vehicle using a hoist or hydraulic lift. Once this has been done, you may begin the removal of your old exhaust system from your vehicle.

Note: Before removing the original exhaust system from your vehicle, please compare the parts you have received with the bill of materials provided on the previous page to assure that you have all the parts necessary for the installation of your new Borla Performance Rear Section Exhaust System.

Borla Performance Rear Section Exhaust System Installation

1. Place Muffler Assembly into position using factory gasket. (See Fig. 4)
2. Insert Right Side Muffler Assembly hangers into factory rubber isolators. Lightly tighten hardware on flanges. (See Fig. 7)
3. Place clamp on Insert Left Side Muffler Assembly inlet and insert hangers into factory rubber isolators. (See Fig. 8)
4. Check your exhaust for proper clearance under the vehicle and also for tip alignment. Tighten flange bolts 18-22 ft.lbs torque. Tighten clamp 35 ft.lbs. (See Fig. 9 & 10)
5. Start vehicle and check for any leaks. If any leaks are found, determine cause (such as loose hardware) and repair as necessary.

Note: When you first start your vehicle after the installation of your new Borla Performance Exhaust System, there may be some smoke and fumes coming from the system. This is a protective oil based coating used in the manufacturing of mandrel bent performance exhaust tubing. This is not a problem and will disappear within a very short period of time after the exhaust has reached normal operating temperatures.

