

Exhaust System Installation For Corvette C6 PN's-11810,11811,11812 & 11814,11815,11816



These instructions have been written to help you with the installation of your Borla [Performance Exhaust System](#). Please read this document completely before beginning the installation of your system.

Please compare the parts in the box with the bill of materials provided to assure that you have all the parts necessary for this installation.

Thank you for purchasing a Borla Performance Rear-Section Exhaust System.

These Borla Performance exhaust systems (PN's 11810,11811,11812,11814,11815,11816) are designed for the Chevrolet Corvette C6 equipped with a 6.2L V-8 engine, automatic or manual transmissions.

Borla Performance Industries recommends that an exhaust shop or professional after market parts installer, who has all the necessary equipment, tools and experienced personnel needed for proper installation, should perform the installation of this system. However, if you decide to perform the installation, we recommend someone should help you. Ensure the installer uses all under car safety precautions including eye protection.

Please take time to read and understand the following...

By installing your Borla Performance Exhaust System, you indicate that you have read this document and you agree with the terms stated below.

It is the responsibility of the purchaser to follow all installation instruction guidelines and safety procedures supplied with your Borla Performance Exhaust System

Borla Performance Industries assumes no responsibility for damages occurring from misuse, abuse, improper installation, improper operation, lack of responsible care, or all previously stated reasons resulting from incompatibility with other manufacturer's products and/or systems.

Included with your Borla Performance Exhaust System is a warranty card. Please read it carefully before you begin any work on your vehicle. If you should have any questions regarding our warranty policy, installation, or any other matter pertaining to your new Borla Performance Exhaust System, please give us a call at the number provided on the warranty card.

Minimum Required Tool List:

TOOLS:

1. 3/8" Drive Ratchet
2. 3/8" Drive Extension 3"
3. 15mm Deep Well Socket
4. 18mm socket
5. 13mm socket
6. Pry Bar

SHOP SUPPLIES:

- 1 Spray Lubricant

Borla Performance Cat-back™ Bill of Materials

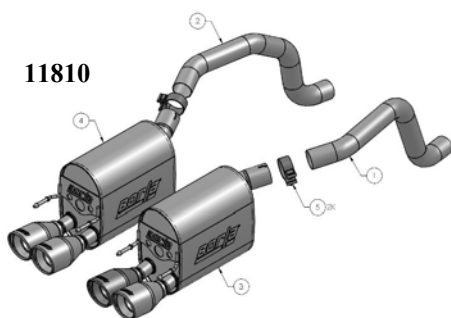

ITEM NO.	QTY.	PART NO.	DESCRIPTION
1	1	47495	R/H OVER-AXLE PIPE Ø2.50 X 32.00" (FROM 80007)
2	1	47496	L/H OVER-AXLE PIPE Ø2.50 X 32.00" (FROM 80007)
3	1	54506	R/H MUFFLER ASSEMBLY
4	1	54507	L/H MUFFLER ASSEMBLY
5	2	90113	S/S ACCU-SEAL CLAMP Ø2.50

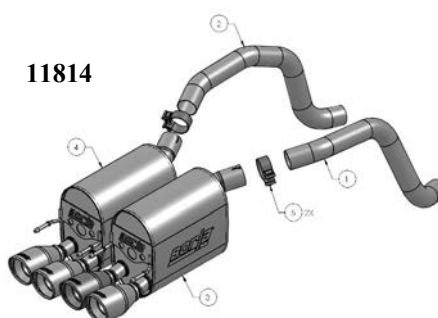

ITEM NO.	QTY.	PART NUMBER	DESCRIPTION
1	1	47497	R/H OVER-AXLE PIPE Ø2.50 X 32.00"
2	1	47498	L/H OVER-AXLE PIPE Ø2.50 X 32.00"
3	1	54506	R/H MUFFLER ASSEMBLY
4	1	54507	L/H MUFFLER ASSEMBLY
5	2	90113	S/S ACCU-SEAL CLAMP Ø2.50

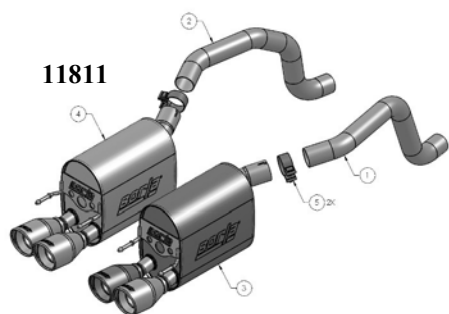

ITEM NO.	QTY.	PART NO.	DESCRIPTION
1	1	47495	R/H OVER-AXLE PIPE Ø2.50 X 32.00" (FROM 80007)
2	1	47496	L/H OVER-AXLE PIPE Ø2.50 X 32.00" (FROM 80007)
3	1	54506	R/H MUFFLER ASSEMBLY
4	1	54507	L/H MUFFLER ASSEMBLY
5	2	90113	S/S ACCU-SEAL CLAMP Ø2.50

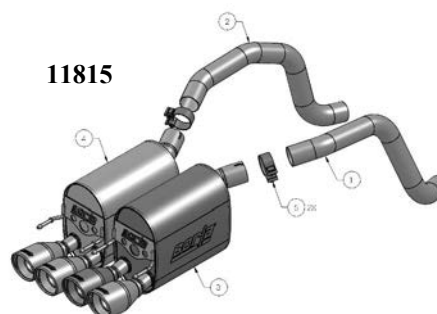

ITEM NO.	QTY.	PART NUMBER	DESCRIPTION
1	1	47496	R/H OVER-AXLE PIPE Ø2.50 X 32.00"
2	1	47497	L/H OVER-AXLE PIPE Ø2.50 X 32.00"
3	1	54506	R/H MUFFLER ASSEMBLY
4	1	54507	L/H MUFFLER ASSEMBLY
5	2	90113	S/S ACCU-SEAL CLAMP Ø2.50

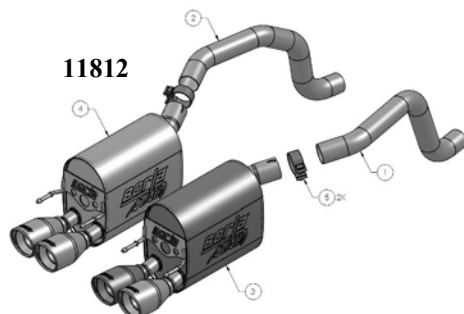

ITEM NO.	QTY.	PART NO.	DESCRIPTION
1	1	47495	R/H OVER-AXLE PIPE Ø2.50 X 32.00" (FROM 80007)
2	1	47496	L/H OVER-AXLE PIPE Ø2.50 X 32.00" (FROM 80007)
3	1	54499	R/H MUFFLER ASSEMBLY
4	1	54500	L/H MUFFLER ASSEMBLY
5	2	90113	S/S ACCU-SEAL CLAMP Ø2.50

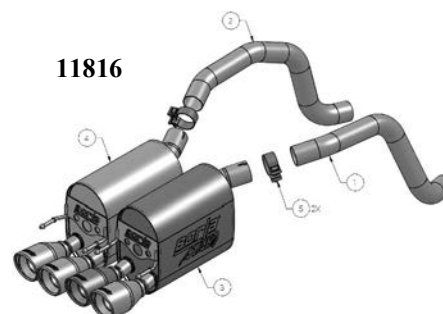

ITEM NO.	QTY.	PART NUMBER	DESCRIPTION
1	1	47497	R/H OVER-AXLE PIPE Ø2.50 X 32.00"
2	1	47498	L/H OVER-AXLE PIPE Ø2.50 X 32.00"
3	1	54499	R/H MUFFLER ASSEMBLY
4	1	54500	L/H MUFFLER ASSEMBLY
5	2	90113	S/S ACCU-SEAL CLAMP Ø2.50

Caution!!! *Never work on a hot exhaust system. Serious injury in the form of burns can result* If the vehicle has been in use and the exhaust system is hot, allow vehicle to cool for at least 1 hour. Always wear eye protection when working under any vehicle.

Note: It is our recommendation that you use a hoist or hydraulic lift to facilitate the installation of your new Borla Performance Rear Section Exhaust System.

Taking all under car safety precautions, lift the vehicle using a hoist or hydraulic lift. Once this has been done, you may begin the removal of your old exhaust system from your vehicle.

Note: Before removing the original exhaust system from your vehicle, please compare the parts you have received with the bill of materials provided on the previous page to assure that you have all the parts necessary for the installation of your new Borla Performance Exhaust System.

Original Exhaust System Removal

Note: With a used vehicle, we suggest a penetrating spray lubricant to be applied liberally to all exhaust fasteners and allowing a significant period of time for the chemical to lubricate the threads before attempting to disassemble.

1. Remove hardware holding rear anti-sway bar to frame (keep hardware for reinstallation later). Reposition anti-away bar below for clearance and installation of your new exhaust. (See Fig. 1)
2. NPP equipped vehicles: Disconnect and plug, and secure vacuum hose from exhaust valves.
3. Loosen the clamps on the pipe in front of the rear axle. Remove the hardware on the hangars connecting the pipe to the vehicle. Keep this hardware for installation of your new exhaust system. Remove the mid-pipe. (See Figs. 2 & 3)
4. Carefully remove the rear mufflers from the rubber isolators. (See Fig.4)

Warning: Use extreme caution during installation. Torque all fasteners according to manufacturer's torque values and tightening sequence. **DO NOT** use air impact tools to tighten fasteners on Borla Performance Exhaust Systems. Use of such tools may result in bent flanges or gasket contact areas leading to exhaust leaks.

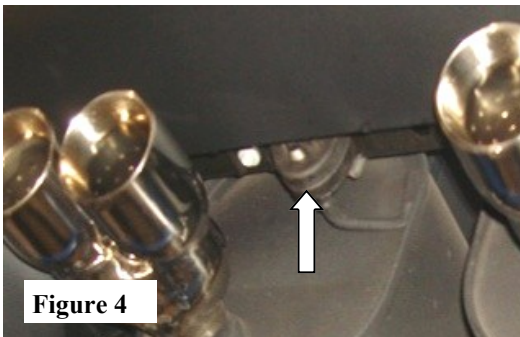
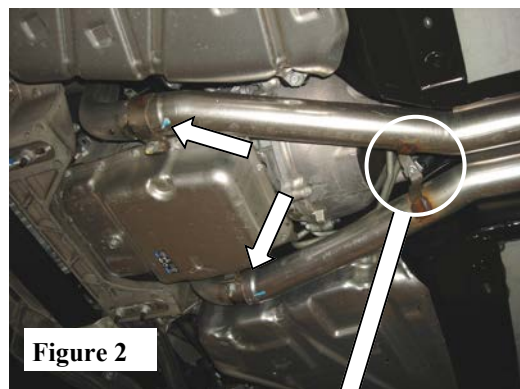
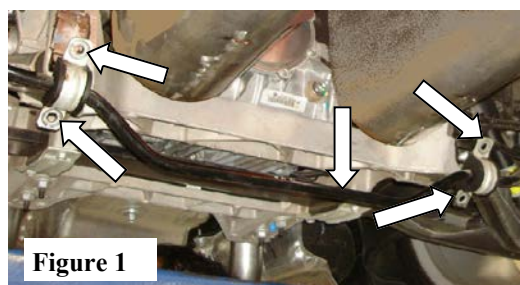

Borla Performance Exhaust System Installation

1. Orient components on floor referencing page-2 drawing.
2. Place a clamp over each expanded ends of each Over-Axle Pipe. Starting with the R/H Muffler Assembly, and insert inlet into R/H Over-Axle Pipe and carefully insert hangars into runner isolators. Repeat step for the L/H Muffler Assembly. (See Fig. 7) **DO NOT TIGHTEN HARDWARE.**
3. Reinstall original anti-sway bar hardware.
4. Check your exhaust system for proper clearance under the vehicle and also for tip alignment. Starting at front flanges and moving to rear of vehicle, tighten flange hardware bolts. Orient position of bolt (on supplied clamps) between (not over) pipe notches and tighten to 35 ft. lbs. torque. (See Fig.8)
5. Align tips and tighten hardware. Loosen clamps to rotate or slide pipe for better alignment. (See Fig. 9)
6. Before starting your vehicle, make sure to check all wires, hoses, brake lines, body parts and tires for safe clearance from the exhaust system.
7. Start vehicle and check for any leaks. If any leaks are found, determine cause (such as loose or incorrectly positioned clamp) and repair as necessary.

Congratulations!!! You have completed the installation of the world famous Borla Performance Stainless Steel Exhaust System.

Note: When you first start your vehicle after the installation of your new Borla Performance Exhaust System, there may be some smoke and fumes coming from the system. This is a protective oil based coating used in the manufacturing of mandrel bent performance exhaust tubing. This is not a problem and will disappear within a very short period of time after the exhaust has reached normal operating temperatures.

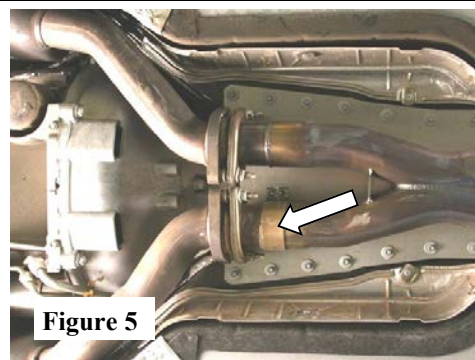

Figure 5

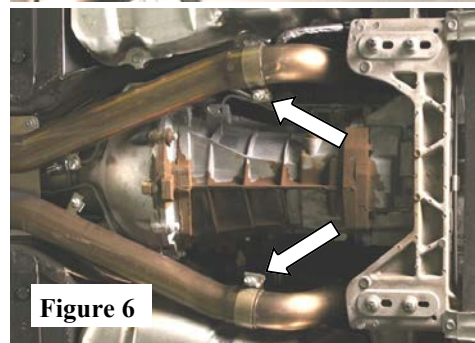

Figure 6

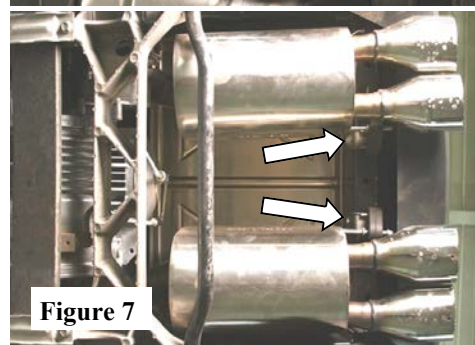

Figure 7

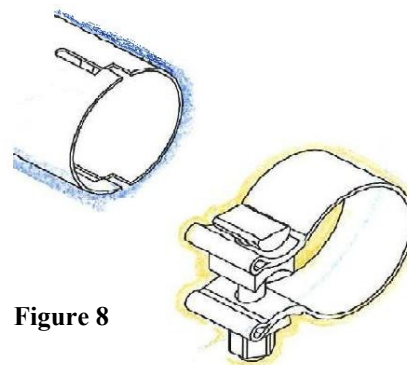

Figure 8

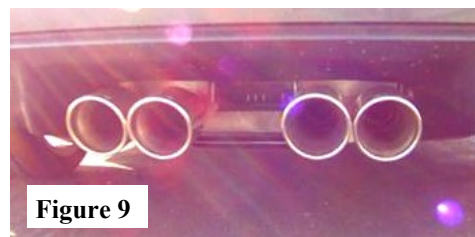

Figure 9