

**Side Guard Installation - Jeep JK Unlimited**

Step 1 Check parts / hardware list and confirm all parts and necessary hardware are included before installation. It's a good idea to spray all OE attaching hardware with penetrating oil before beginning removal of OE bolts. This will ease removal as well as help assure that none of the bolts' / nuts' threads are damaged during removal.

- Step 2
- a. If your vehicle is equipped with the factory steps or side bars, they will need to be removed prior to installation of the Body Armor RockCrawler Side Guards.
  - b. Start with the Passenger side. Refer to Figure 1(below) for proper placement of each bracket.
  - c. Identify the 2 factory holes located in the undercarriage of the vehicle. If necessary you may need to install a "T" bolt in to the square opening making sure you center it in the hole as shown in Photo group1. (next page)
  - d. Slide the "T" bolt up into the body with the bolt facing down through the hole. Use factory threaded nut in the undercarriage if equipped.
  - e. Locate the 2 sets of holes (4 total) in the factory pinch weld. Start with the front set. Attach a bracket (#2) to the pinch weld using a 8mm bolt, nut and washer for the front hole and 6m bolt, nut and washer for the rear hole. Repeat with 8MM and 6MM bolts on rear bracket.
  - f. Loosely fit all brackets with hardware. Once all brackets are attached tighten all hardware prior to installing side bars.

Step 3 Identify the passenger and driveside bar by lining them up so that they match the brackets that are mounted on the vehicle.

- Step 4 With the aid of a helper, hold up the side guard to the pinchweld and attach them to the mounting brackets using the
- a. 10mm bolts, nuts and washers as shown in Photo #3. (next page).

Repeat steps on passenger side (as in diagram below).  
See Photos on the next page for reference.

\*\*\*We recommend you check the torque of all bolts after about two weeks, and after every off-road / trail run to assure tightness.

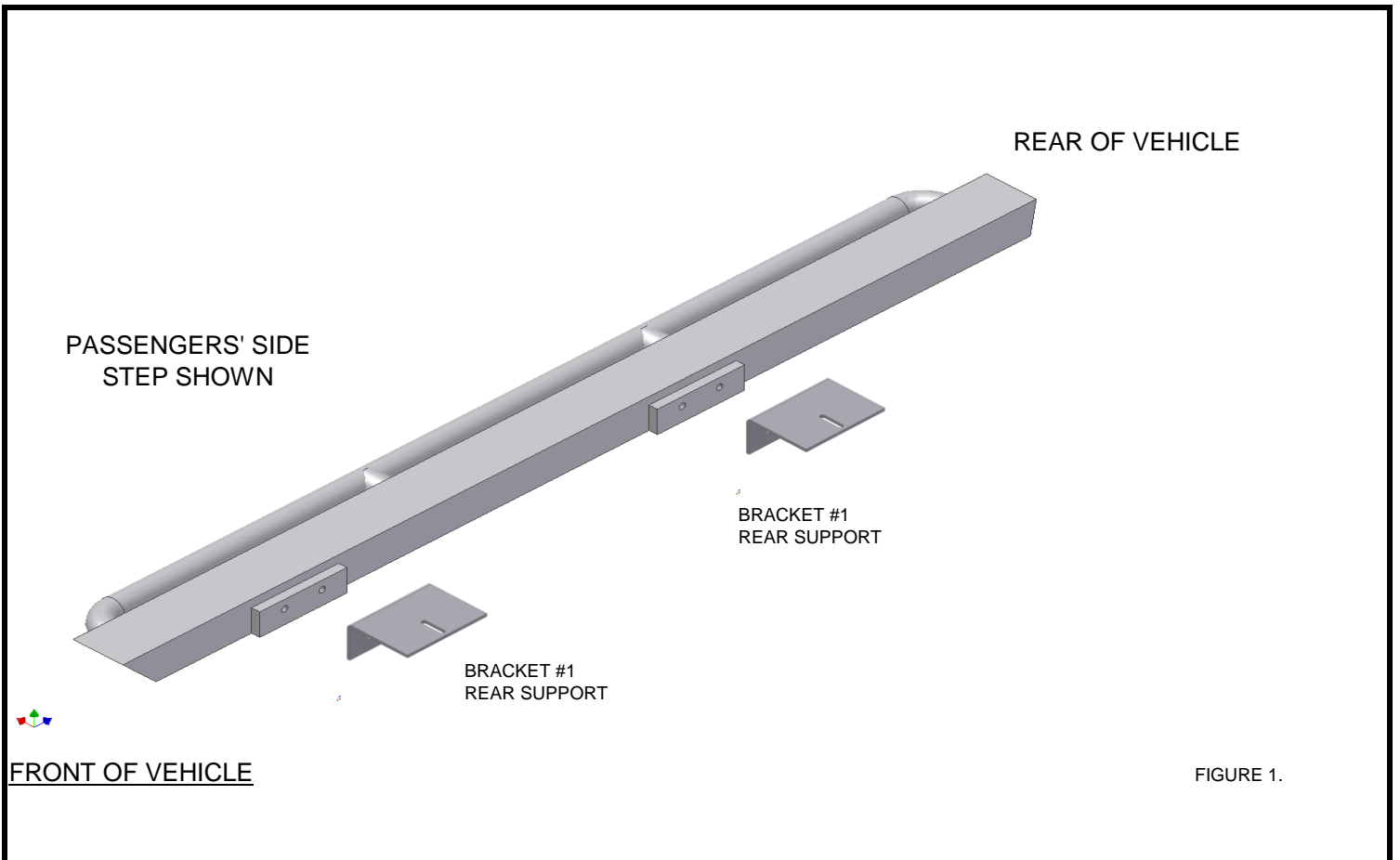

FIGURE 1.