



## TAS005 TORQUE ARM CONVERSION INSTALLATION INSTRUCTIONS 1970-1981 Camaro and Firebird – Ford 9” rear

### Please take note before proceeding with this installation:

- *This product may interfere with certain exhaust kits. Exhaust crossovers are not compatible with this torque arm suspension. In some circumstances, it may be necessary to fabricate a custom exhaust to insure adequate clearance.*
- *A service lift, while not necessary, is recommended for this installation.*

### TOOLS REQUIRED:

3/8” and 1/2” drive ratchets	9/16”, 3/4”, 15/16” wrenches
3/8”, 9/16”, 3/4”, 15/16” and 1-1/8” sockets	Rubber mallet
Pry-bar	Drill
3/8” Allen wrench	Step bit or 1/2” and 3/4” drill bits
Jack stands	Hydraulic Jack
Grease gun with synthetic lube	Torque wrench
Welder (optional)	Plumb bob and tape measure

### CROSS-MEMBER INSTALLATION:

- 1) Lift the vehicle and support with stands under the rocker panel pinch seams (Do not place stands under the subframe).
- 2) Remove the exhaust system.
- 3) Using a 15/16” socket, remove the rear two body mount bolts.
- 4) Remove the OE rubber body mount bushings. They are composed of an upper and lower bushing that “sandwich” the subframe together in the middle.  
**NOTE:** it may be necessary to use a pry-bar to lower the subframe enough to remove these bushings.

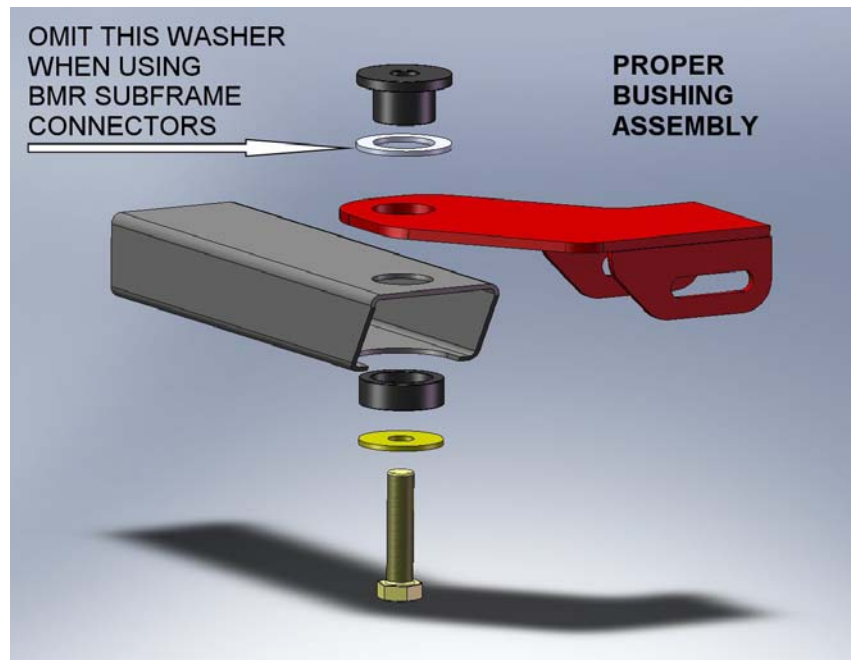

- 5) Once the OE bushings have been removed, inspect the subframe for rust damage. This is a common area susceptible to rust and if the mounting point is compromised, it needs to be repaired before proceeding with the installation.
- 6) Begin with the driver’s side. Assemble the driver’s side frame mount, billet body mounts and washer (if necessary) as shown in the image above. If you are using BMR subframe connectors or any subframe connector that mounts around the body bushing, omit the supplied aluminum spacer washer shown in the above image.



## CROSS-MEMBER INSTALLATION (Cont.)

- 7) Thread the supplied bolt into the body and snug the bolt allowing the frame bracket to rotate around the axis of the bushing.
- 8) Repeat steps 4-7 for the passenger side. At this stage both mounts should be installed and you can mount the cross-member. Lift the cross-member into place and insert the supplied ½" x 4.5" bolts, stainless washers, and nuts.
- 9) Tighten the body mount bolts to 150 ft/lbs.
- 10) Center the cross-member to the driveshaft then tighten the (4) cross-member bolts.



## TORQUE ARM INSTALLATION:

1. Lift vehicle and support with stands under the frame, allowing the rear end to hang.
2. Remove the rear wheels/tires.
3. If the vehicle has exhaust installed, remove it at this time.
4. Remove the rear shocks using a 9/16" socket.
5. While not necessary, the installation is simpler if the fuel tank is removed. If you do not wish to remove the fuel tank, skip steps 6-8 and proceed to step 9.
6. Drain the tank using a drill pump or siphon.
7. Support the tank and then remove the two mounting nuts using a 9/16" deep socket. Pull the tank support straps down, allowing the tank to be lowered. **(Image 1)**
8. Lower the tank far enough to access the fuel lines and electrical connectors. Disconnect and cap the fuel lines. Lower and remove the fuel tank.



(CONTINUED)

9. Support the rear end with jack stands.
10. Using a 3/4" socket, remove the leaf spring U-bolts on the rear end. **(Image 2)**  
*NOTE: the image shown has aftermarket traction bars installed. Leaf spring mounts may appear slightly different in nature.*
11. Using a 5/8" socket, loosen and remove the rear leaf spring shackle bolts. Loosen the upper shackle bolt at the frame and remove the shackles. **(Image 3)**



12. Using a 9/16" socket, remove the (3) bolts on the front spring mount of each leaf spring. **(Image 4)** *NOTE: the image shown had aftermarket traction bars installed. Front leaf spring eye may appear slightly different in nature.*
13. Once all bolts are removed, remove the leaf springs.
14. Remove the rear end and set aside.
15. Loosen the bolts and remove the front spring pockets. **(Image 5)**
16. Install the BMR trailing arms into the leaf spring pockets as shown using the provided 1/2" x 5" bolts. Thread a stainless washer under the nut then tighten to 80 ft/lbs. **(Image 6)**
17. Re-install the spring pockets with control arms into the body and leave bolts finger tight.

(CONTINUED)



18. The next few steps involve installation of the shock cross-member. Begin by removing the factory muffler hangers located above the rear end. (**Image 7**).

19. **NOTE:** *Images 8 and 9 have been omitted due to updated design.*

20. The cross-member can be welded or bolted into place. Locating the shock cross-member properly is important and, while it can be performed by one person, it is much easier with a helper. Have a helper hold the shock cross-member up into place on the frame rails. Slide the cross-member as far forward as it will allow.

21. Use the fuel tank strap mounting positions as a reference point to locate the cross-member properly front-to-back and to insure that the cross-member is mounted square in the body. As shown in **Image**

**10**, measure the distance from the relief in the trunk pan to the main cross tube of the cross-member. Vehicle production variance prevents a “one measurement fits all” figure

but the measurements should fall somewhere between 3-7/8” to 4-1/16” when viewing the tape measure from directly below. Re-position the cross-member until the reading from each strap mount relief is equal and falls within the range listed above.



(CONTINUED)

22. Once properly positioned, locate the provided sheet metal screws in the hardware pack. As shown in **Image 11**, screw the cross-member into each frame rail to hold it into position for the upcoming steps.

*NOTE: the cross-member should draw up tight against the frame rail. Any floor pan deformations that prevent the cross-member from fitting flush against the frame rail should be adjusted using a pry-bar or rubber mallet.*

23. At this step the cross-member may be welded to the subframe or bolted. If bolting is preferred, proceed to step 24. If welding is preferred, remove the cross-member and prep it for welding by grinding the powdercoat off at the weld points. Remove all paint, undercoating and scale from the weld area on the subframe then re-install the cross-member. Weld a full 2" bead vertically on each end of the plate and at least 4 inches of weld horizontally on each side. Wire brush and paint the weld area with rust preventive paint. Proceed to step 30.

24. If bolting the cross-member into place, begin on the passenger side. Position the provided frame reinforcement plate as shown in **Image 12**. The outside perimeter of the reinforcement plate should match that of the shock cross-member.

25. Mark the frame at the center of the slot using a grease pencil or paint marker. *NOTE: Due to vehicle production variance, it may be necessary to trim the forward portion of the reinforcement plate slightly in order to make it fit squarely to the shock cross-member. The factory shock reinforcement on the frame rail may prevent proper plate alignment if the reinforcement plate is not trimmed. Plate alignment is very important to insure the holes are drilled in the proper location to line up squarely with the shock cross-member holes on the other side of the frame rail.*

26. Center-punch the marks on the frame to provide a drill centerline so the drill bit doesn't wander.

27. The recommended (and easiest) way to drill through the frame rails is with a step-type drill bit. Using a 1/2" bit (or step bit) drill through the outer portion of the frame rail as shown in **Image 13**. Take extra care to angle the drill correctly before drilling through the other side of the frame rail. Continue drilling through the frame rail until the bit starts to appear through the inner bolt holes of the BMR cross-member. In most cases, the



(CONTINUED)

holes in the cross-member will “self-align” the drill bit, forcing the bit to center itself.

28. Once both ½” holes are drilled through the sub frame, it is necessary to enlarge the outer frame holes to ¾” to allow insertion of the provided frame reinforcement inserts. Using either a ¾” drill bit or a step bit (much easier), enlarge ***ONLY*** the outer holes in the frame rail. (**Image 14**)



29. Assemble the outer reinforcement plate, frame inserts, ½” bolts and stainless washers as shown in **Image 15**. There are 2 different length frame spacers. The ½” x 3.25” bolt and 1.85” spacer goes in the rear hole while the ½” x 3.5” bolt and 2.2” spacer goes in the front hole. Slide the assembly through the subframe until the bolts protrude through the BMR cross-member on the inside of the frame rail. Thread a nut and stainless washer onto the exposed portion of the bolts and then tighten these bolts to 80 ft/lbs.

30. Proceed to the driver’s side. The driver’s side frame rail has a frame reinforcement that makes it differ from the passenger side. This requires a different reinforcement plate. Position the plate as shown in **Image 15b** and duplicate steps 24-29 using the remaining spacers and same length bolts.

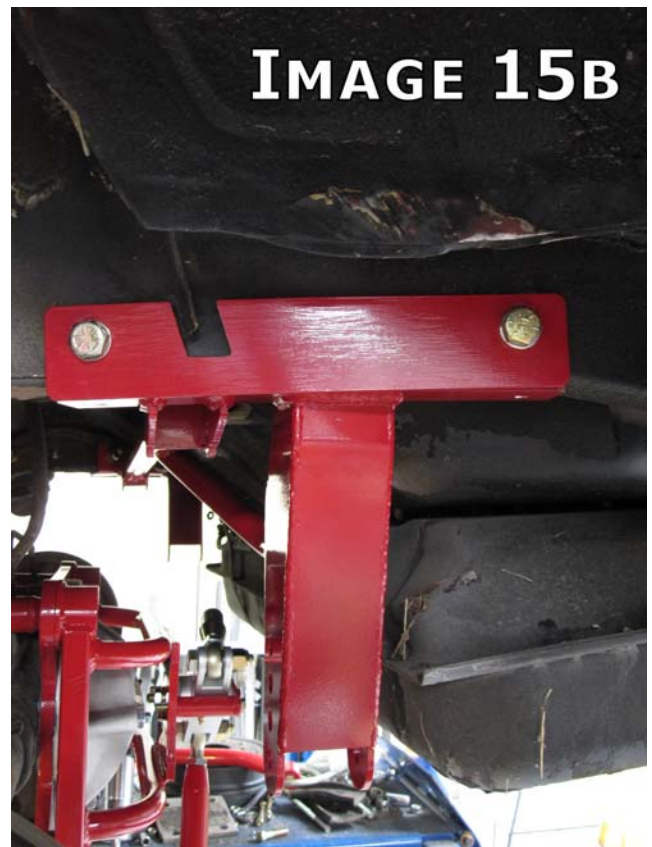

(CONTINUED)

# IMAGE 16



31. At this point it is necessary to assemble the coil-over shocks. Using **Image 16** as a guide, thread the lower adjuster onto the shock body and continue threading until it is all the way to the bottom. Place a spring over the shock and then insert the upper spring mount on top of the spring and over the shock shaft. Insert the spring clip. Thread the lower shock adjuster up until the spring has no more slack and seats squarely on the upper and lower mounts.



32. Position the rear end housing in the wheel wells.
33. Install the Upper Torque Arm braces onto the BMR 9" axle housing as shown in **Image 17** below. This requires two 1/2" x 3.75" bolts, nuts and stainless washers. Place the washer under the nut side and leave the nuts finger tight.
34. Position the front of the torque arm into the mount on the BMR transmission cross-member and insert the provided 1/2" x 4" bolt. Thread a stainless washer and nut onto the exposed threads and tighten to 80 ft/lbs. (**Image 18**)



38. Lift the rear of the torque arm and connect it to the lower mount of the BMR 9" axle housing using one of the provided 1/2" x 3.25" bolts, nuts, & stainless washer. Leave bolts finger tight. **(Image 19)**



39. Position the upper torque arm mounts onto the torque arm and line up the mounting holes as in Image 13 above. Insert the two provided 1/2" x 3.25" bolts, nuts, and (4) large diameter washers, positioning one washer on each side. The two mounting plates should "sandwich" the torque arm between them. Leave all bolts finger tight. **(Image 20)**



40. Slide the upper mount of the shock into the BMR cross-member making sure the shock adjustment knobs are facing inward. Insert the supplied 1/2" x 2.5" bolt. Repeat for the other side. Thread a stainless washer and nut onto the bolt and tighten to 80 ft/lbs. Repeat for the other side. **(Image 21)**

41. Assemble the bottom shock mount as shown in **Image 16b** above using the provided 5/8" x 4" bolt. Place a 5/8" small diameter washer on either side of the poly bushings. Insert the bolt into one of the middle shock mounts located on the control arm mount. *NOTE: it may be necessary to raise or lower the rear end in order to insert the bolt.* **(Image 17)**

42. Place a large diameter washer over the 5/8" bolt inside the control arm mount and then thread a nut onto the bolt. Tighten to 80 ft/lbs.

43. Repeat steps 40-44 for the other side.



(CONTINUED)

44. The next few steps involve mounting the Watts Link. Locate the billet aluminum Watts pivot, the double shear reinforcement plate, (2) 3/8" x 3.75" bolts, and a 1/2" x 4" bolt. Refer to **Image 22** for a visual representation of these components assembled. **NOTE:** *If your vehicle will be setup for a low ride height, choose one of the lower sets of mounting holes to install the Watts pivot. For most applications, this is a good starting point. This mounting point, along with the outer Watts linkage mounting points, determines the vehicles rear roll center (RC) height. Variances in vehicle center-of-gravity (CG) height make multiple mounting locations necessary for fine tuning RC height.*

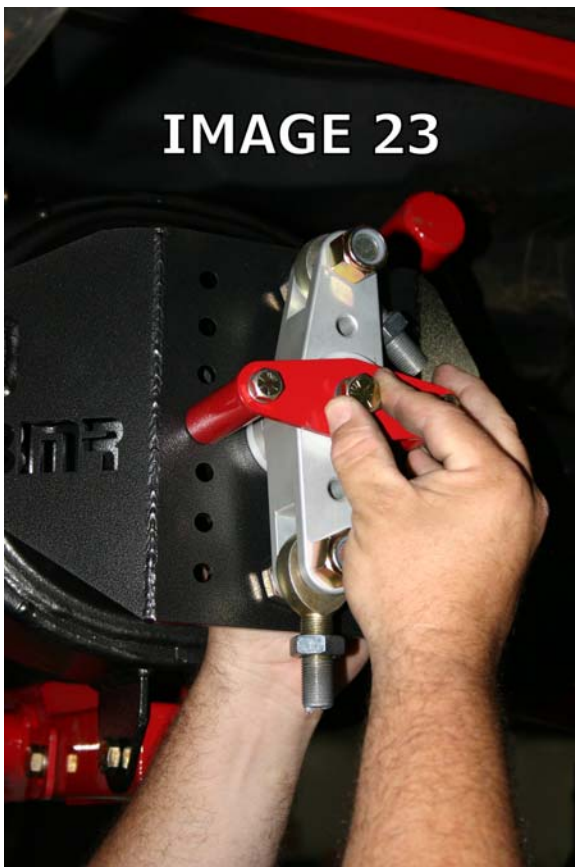
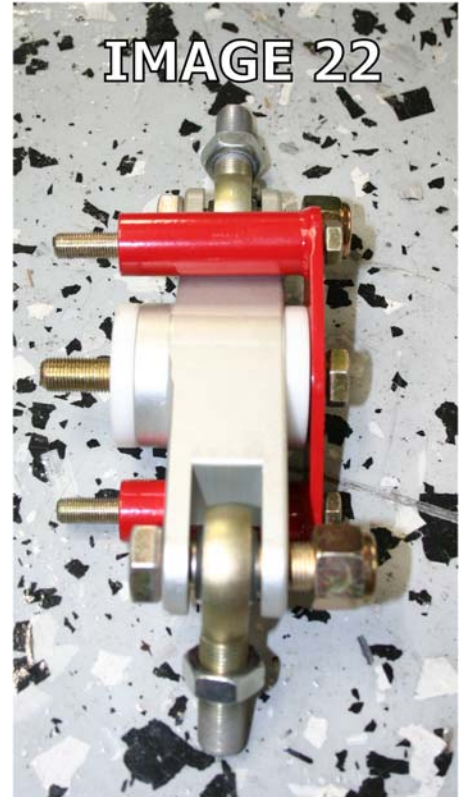

45. Once a mounting location has been determined, tighten the center bolt to 80 ft/lbs. and the smaller outer bolts to 35 ft/lbs. (**Image 23**)
46. Before mounting the Watts link bars, it is necessary to load the vehicles suspension. Allow the weight of the vehicle to sit on the rear end and bounce the car a few times to settle the suspension. If the car sits too high or too low, use the provided spanner wrench at this time to adjust the spring height on the shocks. If it is not possible to adjust the springs enough to achieve the desired ride height, move the lower shock mounting hole to a different location. Once the desired ride height is established, tighten the collar on the shock and proceed to the following step.

(CONTINUED)

47. Thread the drivers' side Watts link arm onto the bottom rod end. The drivers' side arm is the one with the most amount of bend.  
(Image 24)



48. Position the other end of the drivers' side Watts link arm into the frame mount. Position it in the mounting location that places the Watts link bar as level as possible when the Watts pivot is vertical (straight up and down). Insert one of the provided  $\frac{1}{2}$ " x 3" bolts. Thread a stainless washer and nut onto the exposed threads and leave finger tight. (Image 25)



49. Duplicate steps 47-48 for the passenger side Watts link arm.

50. As shown in Image 26, use a plumb bob to determine proper axle location. *NOTE: it is not necessary to remove the wheels and tires to accomplish this, the measurement can also be taken from the wheel itself.* Hold the plumb bob against each wheel well in the same position and measure the axle location in relation to the fender. Adjust the rod ends until each wheel measurement is equal while the Watts link pivot remains vertical (not angled).





51. The above image shows how the setup should look once adjusted correctly. The vehicle should be set to the desired ride height. At this height, the rearend should be centered in the body (side-to-side) with the Watts link vertical (straight up and down) and the Watts link bars as level as possible. Once the above is verified, tighten all mounting bolts. All ½” mounting bolts should be tightened to 80 ft/lbs. It is also very important to tighten the jam-nuts on the Watts link arms and Control arms.
52. Except for final setup, the installation is complete. Double-check all mounting bolts for tightness and inject a few pumps of grease into all of the grease fittings using the supplied silicone based lube. Re-grease the fittings initially after a few miles and then every other oil change thereafter.
53. Re-install the fuel tank and plumb the fuel lines.

### SETTING UP YOUR NEW TORQUE ARM SUSPENSION

1. **Ride Height.** The very first thing that should be done is to establish the desired ride height. Previously the height was determined when the Watts link was setup during the installation process. Most of the time, this setting will be fine however driving the car will settle the suspension slightly and best determine if the height will need to be altered. Drive the car 10-20 miles to insure a consistent ride height and verify suspension travel. *NOTE: the suspension should not bottom out except in extreme road irregularities or very heavy dips. If you are out of spring adjustment on the shock and the suspension is bottoming out, it may be necessary to increase the spring rate. In this case, please contact BMR for technical help in selecting proper rates.*
2. **Trailing Arm Angles.** With the final vehicle height determined, check the trailing arm angles. For proper anti-squat, the trailing arms, when viewed from the side of the car, should angle upward slightly from rear to front (front mount higher than rear mount). If they are level or angled oppositely, lower the rear mounting point. This angle helps determine weight transfer upon acceleration. Each vehicle, depending on front-to-rear weight distribution will vary slightly and favor a “sweet” spot but a slightly upward angle of 1-2 degrees generally is optimal.

(CONTINUED)



- 11) **Driveline angle.** For quiet operation and long u-joint life, driveline angle should not exceed 2-3 degrees negative. The following step involves setting the driveline angle. While this process is actually very simple, it is difficult to explain so we have provided detailed instructions and examples below. Driveline angle is the difference between the pinion angle and the driveshaft angle. Zero degrees means there is no angle and the pinion and driveshaft are straight as viewed from the side. If the angle is negative, the driveshaft and the rear-end will form a “V”. If it is positive, the driveshaft and rear-end will form an “upside down V”.

To check the angle, begin by placing the supplied angle finder onto the rear Watts link mounting plate and record your reading. Take your reading from the drivers’ side of the car. Since the Watts link mounting plate is 90 degrees perpendicular to the pinion, this angle represents the angle of the pinion gear minus 90 degrees. Now place the angle finder on the top of the driveshaft and record the reading from the drivers’ side of the car. This angle represents the driveshaft angle. The goal angle to reach is a 2-3 degree difference between the two recorded angles. For example, our test car used for these instructions had the following readings:

The rear angle on the Watts link mounting plate was 88 degrees. You need to subtract 90 degrees from this to get your pinion angle, resulting in -2. The driveshaft angle just happened to be at 0 degrees. The difference between these two angles is -2, right where we want to be. If your resulting angle is anywhere between 0 and -3, it is an acceptable angle. To adjust this angle, begin by loosening the three cross-bolts at the rear of the torque arm. Do not remove them, they only need to be loosened enough to allow the rear end to be pivoted up or down. Using a pry-bar between the third member and the torque arm, adjust the pinion until the proper angle is achieved. Re-tighten the cross-bolts to 80 ft/lbs.

3. **Shock settings.** An entire book could be written on this subject but we will just touch on the basics. Your AFCO shocks have adjustments for both compression and rebound. It is important to understand that a shocks job is to control the motions of the spring. For optimal control, you never want the spring to collapse or extend too fast. Determining those settings will be different for everybody since vehicle corner weights, desired ride quality, driving behavior, etc. play a role in finding what is optimal for that individual. It is generally best to start with softer settings and work your way up. The idea is to keep the tire firmly planted to the asphalt. Too much of either adjustment will not only create a harsh ride but will force the tires to bounce and lose traction during aggressive driving. The following recommendations are very basic and intended for street driving. Begin with the compression settings at full soft and the rebound settings 2-4 clicks from zero. Drive the car over varying road conditions and work your way up to a setting that feels firm yet still comfortable without excessive bounce over road irregularities. Once the rebound is set, begin adjusting the compression until ride quality begins to suffer then back a click or two. These settings should provide good all-around handling and ride quality, further adjustment may be necessary for very aggressive driving habits such as road course and autocross racing.
4. **Roll Center (Watts Link Height).** Roll center (RC) works in conjunction with the vehicles center-of-gravity (CG) height. Front RC also plays a role in determining an optimal rear RC since too much variance between the two can result in unpredictable and sudden body roll. Since both of these factors vary from car-to-car, finding the ideal



setting will be different for everyone. The difference between the RC and the CG height determines the amount of weight shift (body roll) when cornering. The center hole on the Watts Link mount is a good place to start since it relates to the exact center of the axle. If the vehicle has been lowered excessively, it may be beneficial to begin in one of the lower mounting holes. Find a place for testing where you can aggressively drive around a corner consistently. Try a few settings up and down and choose the one that produces the least amount of body roll.

***NOTE:** remember to relocate the outer Watts link bars whenever you change the Watts Link pivot location. These bars should always be as parallel as possible to minimize the chance for binding in the mount.*

5. **Alignment.** Once all the above settings have been decided, the vehicle should have a 4-wheel thrust angle alignment. This will insure that the rear end is square in the chassis.

