



CP001 CAMBER/CASTER PLATES – 2015+ MUSTANG

TOOLS REQUIRED:

- Hydraulic jack and jack stands
- Spring compressor
- Wrenches and sockets:



Component check list:

Before proceeding with the installation, confirm that you have all components by using the above image and the check list to the right.

Description	QTY
Driver side bearing plate	1
Passenger side bearing plate	1
Stud plate	2
Stud retainer	2
14mm Bearing spacer	2
16mm Bearing spacer	2
3/8" washer	6
3/8" flanged nut	6

COMPONENT IDENTIFICATION





CP001 CAMBER/CASTER PLATES – 2015+ MUSTANG

INSTALLATION:

1. Lift vehicle and safely support with jack stands under the frame rails.
2. Remove the wheels/tires.
3. Remove the sway bar end links as shown in **IMAGE 1**.

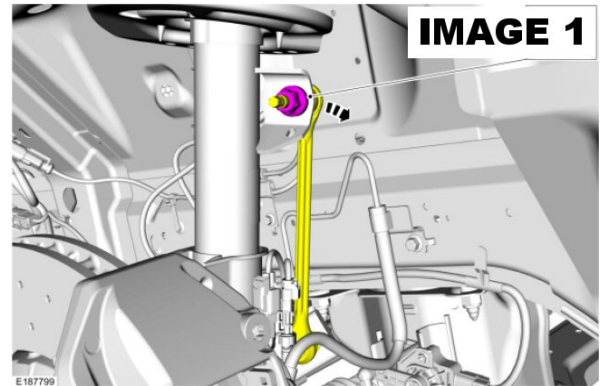

4. Start on the driver side and disconnect all brake sensor connectors from the strut body as shown in **IMAGE 2**.

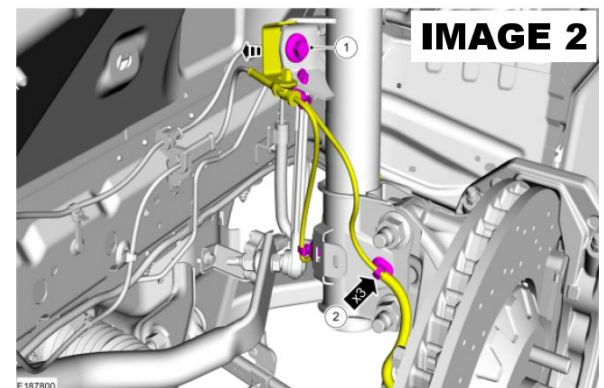

5. Remove the caliper bolts and hang the caliper out of the way. (**IMAGE 3**)

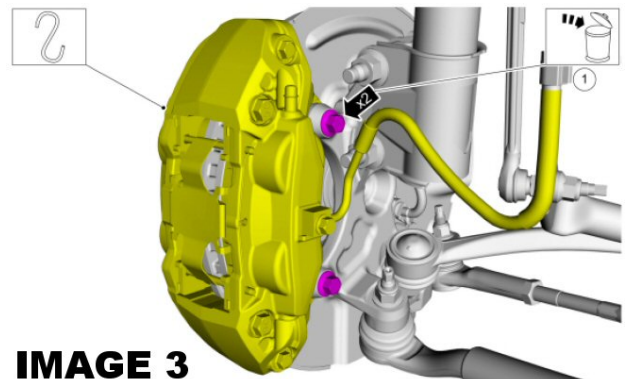

6. Remove the (2) strut bolts at the spindle as shown in **IMAGE 4**.

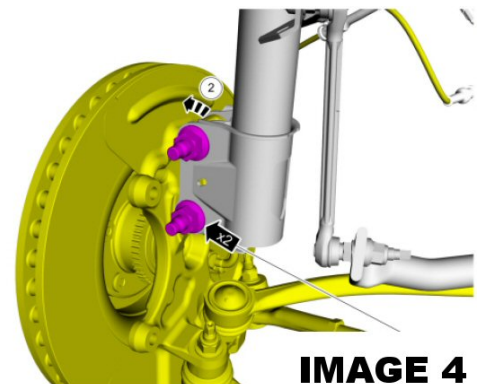

CP001 CAMBER/CASTER PLATES – 2015+ MUSTANG

6. Remove the (3) upper strut mounting bolts in the engine bay as shown in **IMAGE 5** then remove the entire strut/spring assembly from the vehicle.

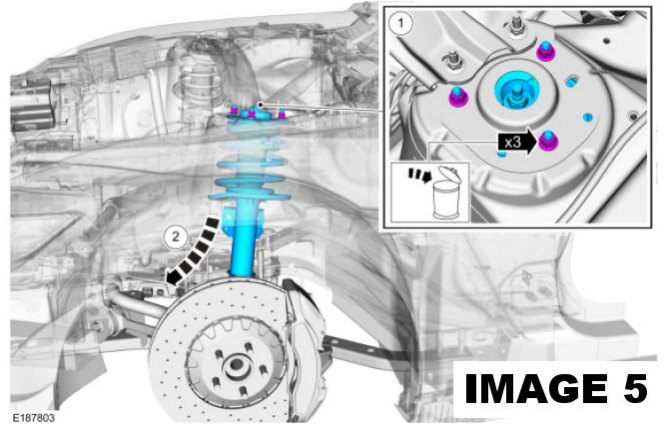

7. Mount the assembly in a spring compressor then remove the upper strut nut to remove the upper spring perch. **IMAGE 6**.

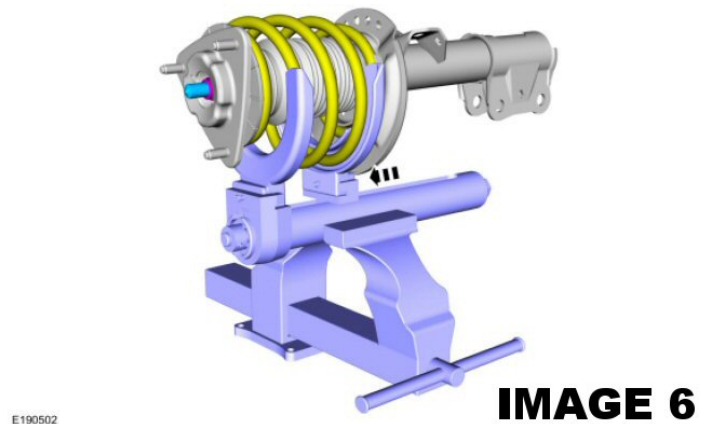

8. Once the upper nut is removed, pull the upper strut mount off the spring/strut assembly. As shown in **IMAGE 7**, separate the upper stud plate from the lower plate and discard the upper stud plate.





CP001 CAMBER/CASTER PLATES – 2015+ MUSTANG

7. Locate the driver side BMR upper bearing plate, stud plate, and bearing spacers. Assemble as shown in **IMAGE 8** and **9**. BMR provides bearing spacers for both stock and larger 5/8" diameter stud shafts, insure that the correct spacer is used during assembly. Note proper orientation of all components. Take proper care to ensure the ends of the spring are seated properly in the upper and lower spring seats. Compress the spring and then tighten the upper strut nut.



NOTE: Images shown are for Driver side.

9. Re-install the strut/spring assembly into the vehicle using steps 3-6 in reverse. Torque the strut-to-spindle nuts to 185 ft/lbs. Torque the sway bar end link nut to 85 ft/lbs. Before installing the upper nuts, place the provided stud retainer over the studs as shown in **IMAGE 10**. Place a 3/8" washer over each stud then thread the provided 3/8" flange nuts onto the studs. Tighten to 46 ft/lbs.
10. Install both wheels and tires then lower the vehicle.





CP001 CAMBER/CASTER PLATES – 2015+ MUSTANG

ADJUSTMENT AND ALIGNMENT RECOMMENDATIONS:

NOTE: Measurements listed at curb load. Curb load is defined as "full service fluids, full fuel tank(s), no passengers and no cargo".

OE SPECIFICATIONS:

ADJUSTMENT	MODEL	SETTING
FRONT CAMBER	Base Coupe, Base Convertible, Performance Package Convertible, Track Package Convertible	-0.74° ± 0.75° LH and RH Total split: 0.0° ± 0.75°
FRONT CAMBER	Performance Package Coupe, Track Package Coupe	-1.03° ± 0.75° LH and RH Total split: 0.0° ± 0.75°
FRONT CASTER	All	7.21° ± 0.75° Total split: 0.0° ± 0.75°
FRONT TOE	All	0.20° ± 0.20°
REAR CAMBER	Base Coupe, Base Convertible, Performance Package Convertible, Track Package Convertible	-1.19° ± 0.75°
REAR CAMBER	Performance Package Coupe, Track Package Coupe	-1.50° ± 0.75°
REAR TOE	All	0.12° ± 0.20° Total split: 0.23° ± 0.20°

BMR DRAG SPECIFICATIONS:

ADJUSTMENT	MODEL	SETTING
FRONT CAMBER	All	-1.5° ± 0.25° LH and RH
FRONT CASTER	All	Greater than 6.5° ± 0.75°
FRONT TOE	All	.07 in per side, .14 total toe (do not exceed .15 total toe in)

BMR HANDLING SPECIFICATIONS: (These are recommended for HPDE, or competition events only. Results may vary, these are baseline settings to start with)

ADJUSTMENT	MODEL	SETTING
FRONT CAMBER	All	-1.5° ± 0.25° -3.0° Max *
FRONT CASTER	All	Greater than 6.5°
FRONT TOE	All	.07 in per side, .14 total toe (do not exceed .15 total toe in) **

* 1.75 for street stock style radials, -2.0 for "200 treadwear" performance tires, -2.5 to -3.0 for "Race" Compound series or comparable

** 0.00 Toe is typically recommended for an initial base setting. Rarely will you want any significant amount of toe "in" – however, all set-ups and drivers are different. Please be aware, running toe out with a significant amount of negative camber can cause accelerated inside should wear and unwanted steering characteristics in some cases.