

BK050 INSTALLATION INSTRUCTIONS

TOOLS REQUIRED:

- Hydraulic jack and jack stands
- Wrenches and Sockets – 8mm, 10mm, 13mm, 14mm, 15mm, 18mm, 19mm, 21mm, 22mm, 32mm
- Sawzall with bi-metal blade
- Large hammer
- Pry bar

INSTALLATION:

1. Lift vehicle and safely support with jack stands under the rocker pinch welds.
2. Remove both rear wheels and tires.
3. Use a 15mm wrench to loosen the 4 exhaust bolts up by the transmission. Use a 13mm wrench to loosen the 6 exhaust bolts at the rear. Remove the exhaust.
4. Mark the driveshaft with a permanent marker or grease pencil to maintain the proper index for re-installation. Now remove the 6 bolts on the rear of the driveshaft using a 10mm socket. **IMAGE 1**
5. Using a 15mm socket, remove the two lower bolts on each shock as shown in **IMAGE 2**.
6. Disconnect the differential vent tube as shown in **IMAGE 3**.

Continued

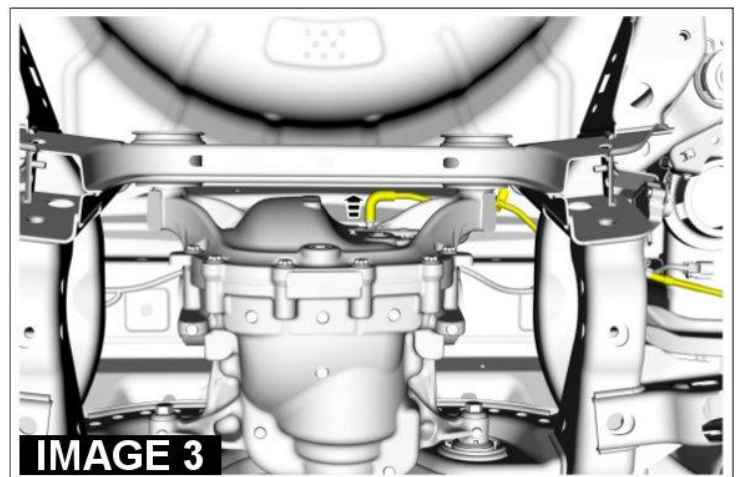
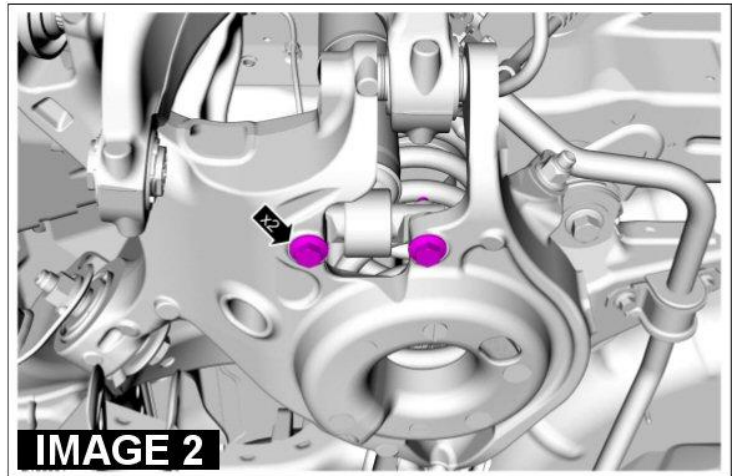
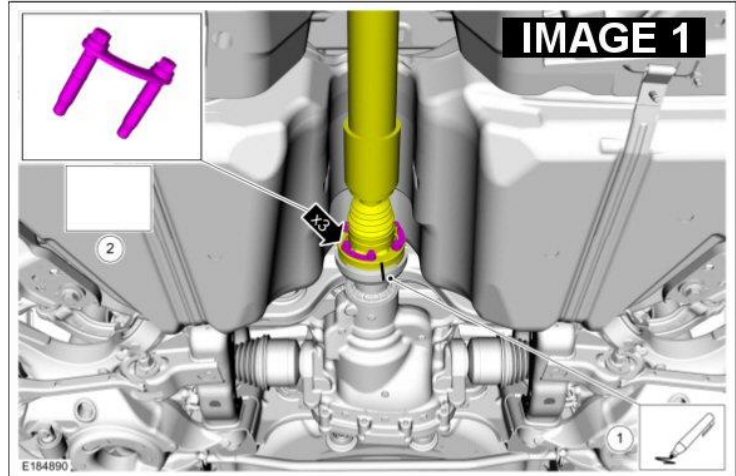

BK050 INSTALLATION INSTRUCTIONS

Continued

7. Loosen the emergency brake cable using a 10mm wrench or socket. See **IMAGE 4**.
8. Remove the two caliper bolts per side using a 14mm socket. Hang the caliper in the wheel well using a piece of wire or zip tie.
9. Unbolt the ABS line on each side using an 8mm socket. See **IMAGE 4**.
10. You are now ready to lower the cradle assembly. Support the cradle assembly with the hydraulic jack or a transmission jack. Remove the (4) front cradle support bolts shown in **IMAGE 5** using a 13mm socket. Loosen the 4 main cradle bolts using a 21mm socket.
11. Slowly lower the cradle to the floor.
12. Once the cradle assembly is on the floor the first step is to remove the CV shafts. To remove the CV shafts, it is necessary to remove all of the suspension links from the spindle. Start with the vertical links. Using an 18mm wrench for the lower bolt, disconnect the vertical link from the spindle as shown in **IMAGE 6**.
13. Now move on to the lower control arm and sway bar end link. Remove the lower control arm bolt using a 21mm wrench. Use an 18mm wrench and a 6mm Allen wrench to

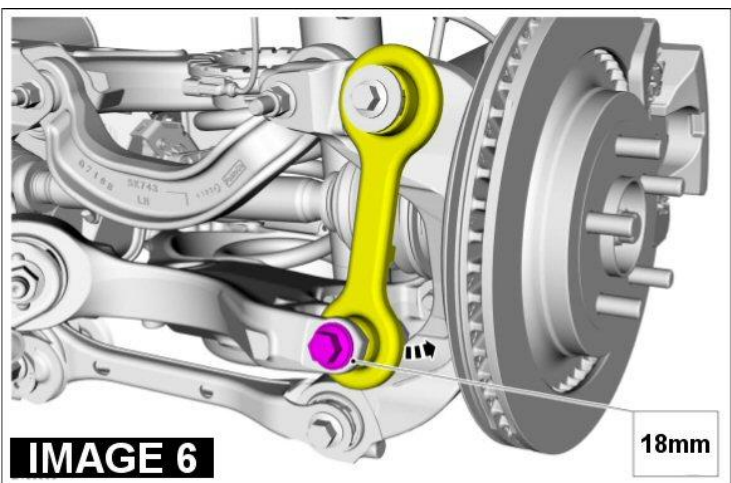
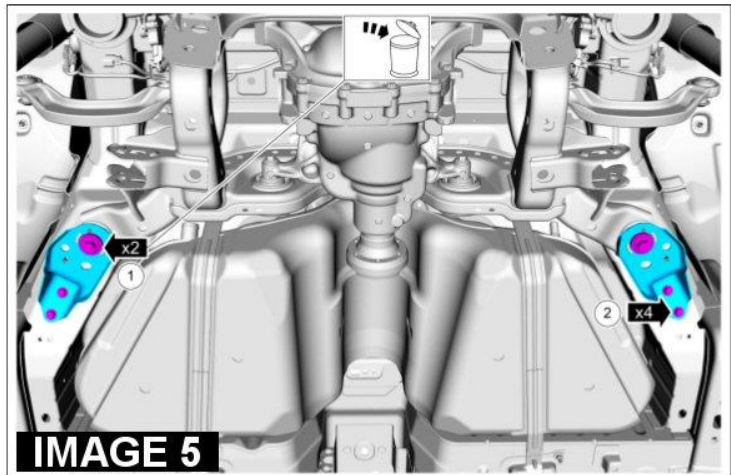
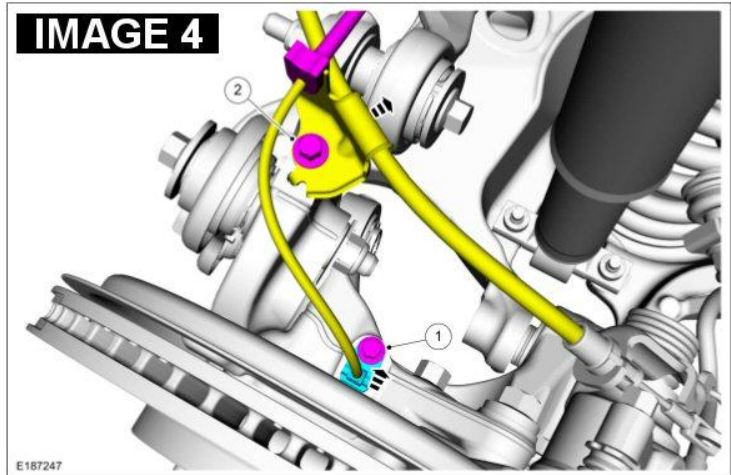

BMR SUSPENSION

BK050 INSTALLATION INSTRUCTIONS

Continued

remove the sway bar end link. The 6mm Allen wrench will keep the shaft from turning while you remove the 18mm nut. See **IMAGE 7**.

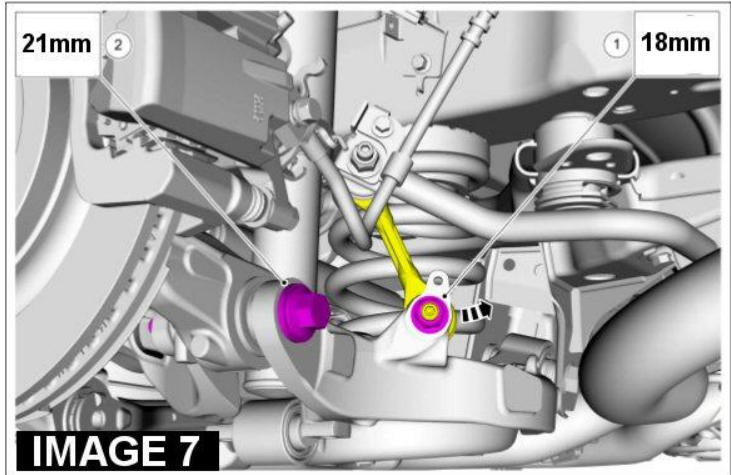

14. Use an 18mm socket to remove the outer bolt on the toe rod shown in **IMAGE 8**.
15. Remove the main CV nut on the outer section of the CV shaft. Once this nut is removed, pull the entire hub/rotor/CV assembly out of the rear end.
16. Duplicate steps 12-15 for the other side.
17. Now you should be ready to remove the differential. Using an 18mm wrench or socket, remove the 4 bolts on the differential. Once removed, pull the differential out of the cradle.

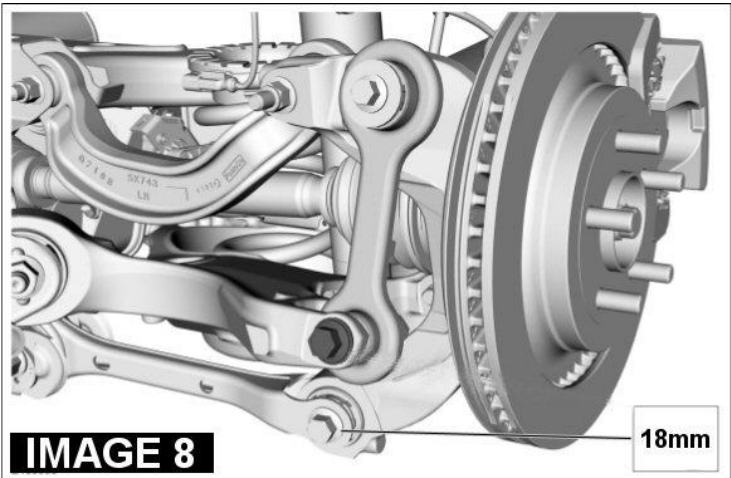

18. The factory differential bushings are pressed in. The simplest way to remove these bushings is with a Sawzall. Force the blade of the Sawzall through the void of the bushing until it goes all the way through. Cut outward through the outer steel sleeve. It is not necessary to cut completely through the sleeve, a small slit in the outer sleeve will relieve enough tension to knock the bushing out.
19. Once the tension is relieved, knock the bushing out with a large hammer. Repeat for the other (3) bushings.
20. Your BMR aluminum differential bushings should be installed with the flange side on the inside. Using a large rubber mallet or preferably a heavy dead blow hammer, knock in all (4) BMR aluminum bushings into the cradle as shown in **IMAGE 9** on the following page. To avoid rattling, BMR machines their bushings on the tighter side of the scale. Be aware that it takes a significant amount of force to fully seat the bushings into the cradle.

BMR SUSPENSION

BK050 INSTALLATION INSTRUCTIONS

Continued

21. Re-install the differential into the cradle using the BMR supplied bolts, nuts, and washers. Use the 14mm x 100mm bolts and washers for the rear bushings. Use the 14mm x 120mm bolts and nuts on the front bushings with a washer on both sides of the bushing. **NOTE:** It is important to thread the rear bolts in first before knocking the fronts in. This will prevent ruining the threads in the aluminum differential cover.



22. Tighten all hardware to 129 ft/lbs using a 22mm wrench and socket.
23. Re-install the CV shafts and spindles.
24. Re-install the toe rod bolt and tighten to 129 ft/lbs.
25. Re-install the outer lower control arm bolt and tighten to 203 ft/lbs.
26. Connect the sway bar end link and tighten.
27. Re-install the upper control arm and tighten to 76 ft/lbs.
28. Re-connect the vertical link to the spindle. Tighten the lower bolt to 129 ft/lbs.
29. Lift the cradle back up into the car. Make sure the springs and shocks are aligned properly before tightening the cradle mounting bolts. Refer back to **IMAGE 5** and install the front cradle support brackets. Thread the (4) large cradle bolts up into the body but do not tighten yet. Insert the (4) small bolts with the 13mm heads into the front cradle support brackets but do not tighten. Continue lifting the cradle until it starts to lift the vehicle off the stands. Tighten all (4) cradle bolts to 129 ft/lbs. Tighten the (4) smaller bolts to 41 ft/lbs.
30. Insert the (4) lower shock bolts and tighten to 35 ft/lbs.
31. Re-connect the ABS line and emergency cable brackets and tighten the bolts.
32. Re-connect the calipers and tighten the bolts.
33. Re-connect the driveshaft and tighten the 6 bolts to 41 ft/lbs.
34. Re-connect the differential vent tube.
35. Install the wheels/tires and lower vehicle.