

BK047 INSTALLATION INSTRUCTIONS

TOOLS REQUIRED:

- Hydraulic jack and jack stands
- Wrenches and Sockets – 8mm, 10mm, 13mm, 14mm, 15mm, 18mm, 19mm, 21mm, 32mm
- Sawzall with bi-metal blade
- Large hammer
- Pry bar

INSTALLATION:

1. Lift vehicle and safely support with jack stands under the rocker pinch welds.
2. Remove both rear wheels and tires.
3. Use a 15mm wrench to loosen the 4 exhaust bolts up by the transmission. Use a 13mm wrench to loosen the 6 exhaust bolts at the rear. Remove the exhaust.
4. Mark the driveshaft with a permanent marker or grease pencil to maintain the proper index for re-installation. Now remove the 6 bolts on the rear of the driveshaft using a 10mm socket. **IMAGE 1**
5. Using a 15mm socket, remove the two lower bolts on each shock as shown in **IMAGE 2**.
6. Disconnect the differential vent tube as shown in **IMAGE 3**.

Continued

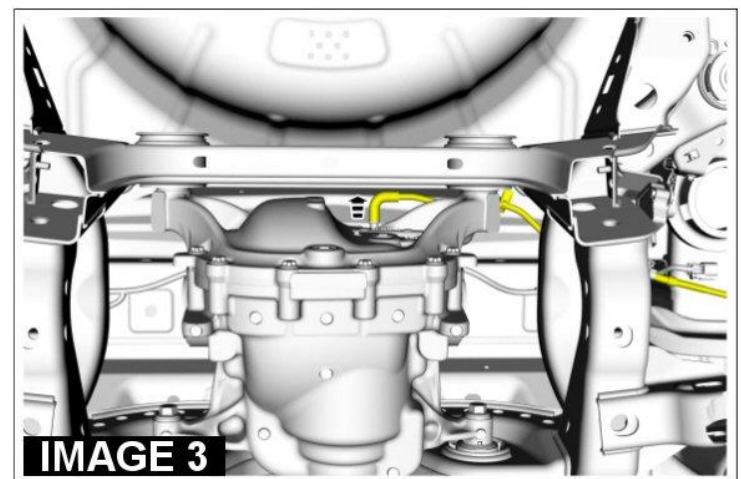
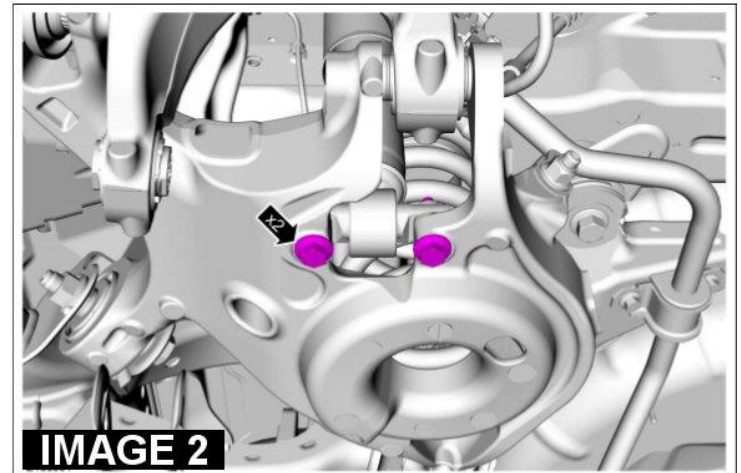
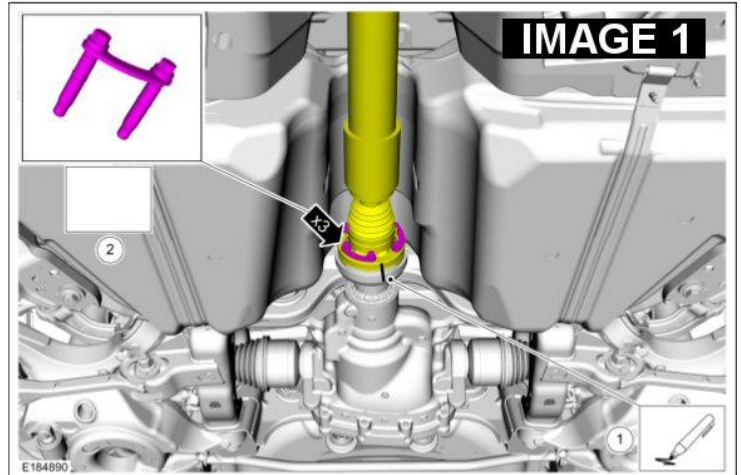

3M SUSPENSION

BK047 INSTALLATION INSTRUCTIONS

Continued

7. Loosen the emergency brake cable using a 10mm wrench or socket. See **IMAGE 4**.
8. Remove the two caliper bolts per side using a 14mm socket. Hang the caliper in the wheel well using a piece of wire or zip tie.
9. Unbolt the ABS line on each side using an 8mm socket. See **IMAGE 4**.
10. You are now ready to lower the cradle assembly. Support the cradle assembly with the hydraulic jack or a transmission jack. Remove the (4) front cradle support bolts shown in **IMAGE 5** using a 13mm socket. Loosen the 4 main cradle bolts using a 21mm socket.
11. Slowly lower the cradle to the floor.
12. Choose which bushing you want to start with. Force the blade of the Sawzall through the void in the bushing. Cut outward through the rubber until the outer shell of the bushing is cut, taking care not to cut the cradle itself. See **IMAGE 6** and **IMAGE 7** for illustration.
13. Using a large rubber mallet or dead blow hammer knock the bushing out of the cradle. Duplicate these steps for all 4 bushings.
14. Identify the proper bushings using **IMAGE 8**. Install the bushings into the cradle using a rubber mallet.

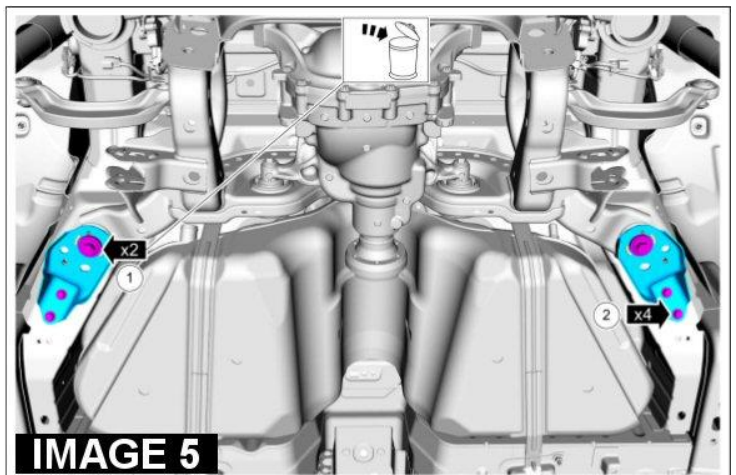
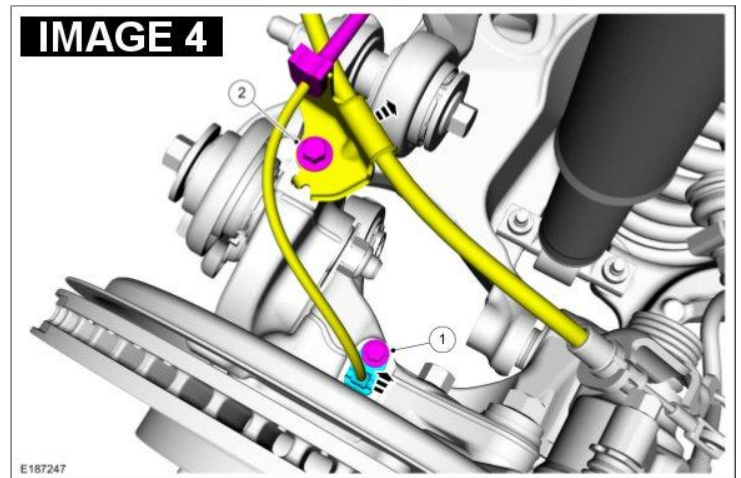

3M3 SUSPENSION

BK047 INSTALLATION INSTRUCTIONS

Continued

15. Observe the aluminum inner bushing sleeves provided in the kit. One end has an inner relief for the serrated shank of the factory bolts. Take care when inserting the aluminum sleeves into the bushings that the reliefs are positioned correctly for the mounting bolts. Once all four bushings and sleeves have been installed, lift the cradle back up into the car. Make sure the springs and shocks are aligned properly before tightening the cradle mounting bolts. Refer back to **IMAGE 5** and install the front cradle support brackets. Thread the (4) large cradle bolts up into the body but do not tighten yet. Insert the (4) small bolts with the 13mm heads into the front cradle support brackets but do not tighten. Continue lifting the cradle until it starts to lift the vehicle off the stands. Tighten all (4) cradle bolts to 129 ft/lbs. Tighten the (4) smaller bolts to 41 ft/lbs.
16. Insert the (4) lower shock bolts and tighten to 35 ft/lbs.
17. Re-connect the ABS line and emergency cable brackets and tighten the bolts.
18. Re-connect the calipers and tighten the bolts.
19. Re-connect the driveshaft and tighten the 6 bolts to 41 ft/lbs.
20. Re-connect the differential vent tube.
21. Install the wheels/tires and lower vehicle.

