



Installation Instructions

Z-Gate Shifter

Part Number 80681

©1998, 2001 by B&M Racing and Performance Products

The **B&M Z-Gate** shifter can be used in vehicles equipped with most popular three speed automatic transmissions. Your **B&M Z-Gate** shifter comes equipped with a neutral safety switch, transmission brackets and levers and a five foot shift cable. Optional shifter cables in 2 ft. (#80830), 3 ft. (#80831), 4 ft. (#80832), 8 ft. (#80834), 10 ft. (#80835) and 12 ft. (#80836) are also available. To use the **B&M Z-Gate** shifter with the Ford AOD transmission you will need our optional accessory kit #40496. See the list on page 8.

Please read the instructions and review the illustrations thoroughly before beginning the installation.

The mechanical components of this shifter are precision made and assembled at our factory. Any modification or disassembly of these parts can cause the shifter to malfunction and will void the warranty. You should disassemble only those items outlined in the instructions.

The vehicle should be about 2 feet off the ground for ease of installation. Use jack stands, wheel ramps or a vehicle lift. Make sure the vehicle is firmly supported before attempting to work on it.

IMPORTANT: If your vehicle is equipped with a locking steering column. Securing the column lock lever in the engine compartment in the full up position will allow the steering wheel to be locked and unlocked and the ignition key to be removed.

WARNING: This allows the steering wheel to be locked **WHENEVER** the ignition key is turned to the "lock" position **WHILE THE VEHICLE IS MOVING, OR**

AT ANY OTHER TIME. Securing the steering column lock lever in any other position will both **PREVENT** the steering wheel from locking and the removal of the ignition key.

INSTALLATION

STEP 1. Remove the stock shift linkage; **Column Shifters:** Remove all rods, levers or cables from the column and the transmission. Place the column shift lever in the Park position. Remove the pin holding the shift lever in the column and remove the lever assembly. If your vehicle is equipped with a locking steering column, secure the column lock lever in the full up position. **WARNING:** This allows the steering wheel to be locked and ignition key removed **WHENEVER** the ignition key is turned to the "lock" position **WHILE THE VEHICLE IS MOVING, OR AT ANY OTHER TIME.**

Console Shifters: Remove the shifter mechanism from the console. Disconnect the rod or cable from the transmission. Remove the cable bracket if equipped. If there is a cable or linkage from the console shifter or the transmission to the steering column lock, it must be blocked in the Park position as described above.

NOTE: The shifter installation may require console modification or complete console removal depending on the space available in your vehicle.

STEP 2. Pull the carpet away from the floorboard where the shifter is to be mounted. If the vehicle has a bench type seat, move seat to the full forward position. Place the shifter on the floor with the

stick shifted to the rearmost position. Locate the shifter for ease and convenience of operation. Make sure the trigger and the knob clear the dash with the shifter in the Park position. Mark the position of four mounting holes on the floor.

STEP 3. Drill four 9/32" mounting holes where marked. Temporarily mount the shifter in place using washers as required to get it level. Mark the location for the shifter cable hole, 3-3/4" ahead of the front shifter mounting hole. Drill or cut a 1" diameter cable hole in the floorboard.

NOTE: Some floorboards are extremely thin and will not adequately support the shifter mechanism when bolted to the floor. For those vehicles we recommend that you fabricate a stiffener plate for additional strength.

STEP 4. Install (but do not secure) the carpet back to it's original position. Cut holes in the carpet for the mounting holes and the cable. **DO NOT** use a drill bit to make the holes in the carpet.

STEP 5. (This step is omitted on 1969 and later Chrysler vehicles.) Assemble the neutral safety switch and the backup light switch to the shifter using two #4-40 screws, nuts and lock washers, as shown in **Figure #1**. The backup light switch is on the other side of the backing plate and is not seen in the illustration.

Beware, over tightening the switch attachment screws will crack the switch housings. Install the switch assembly on the shifter. To adjust the switch loosen the screws and slide the switches as required, then retighten the screws.

STEP 6. Install the cable on the shifter as shown in **Figure #1**. The cable attach-

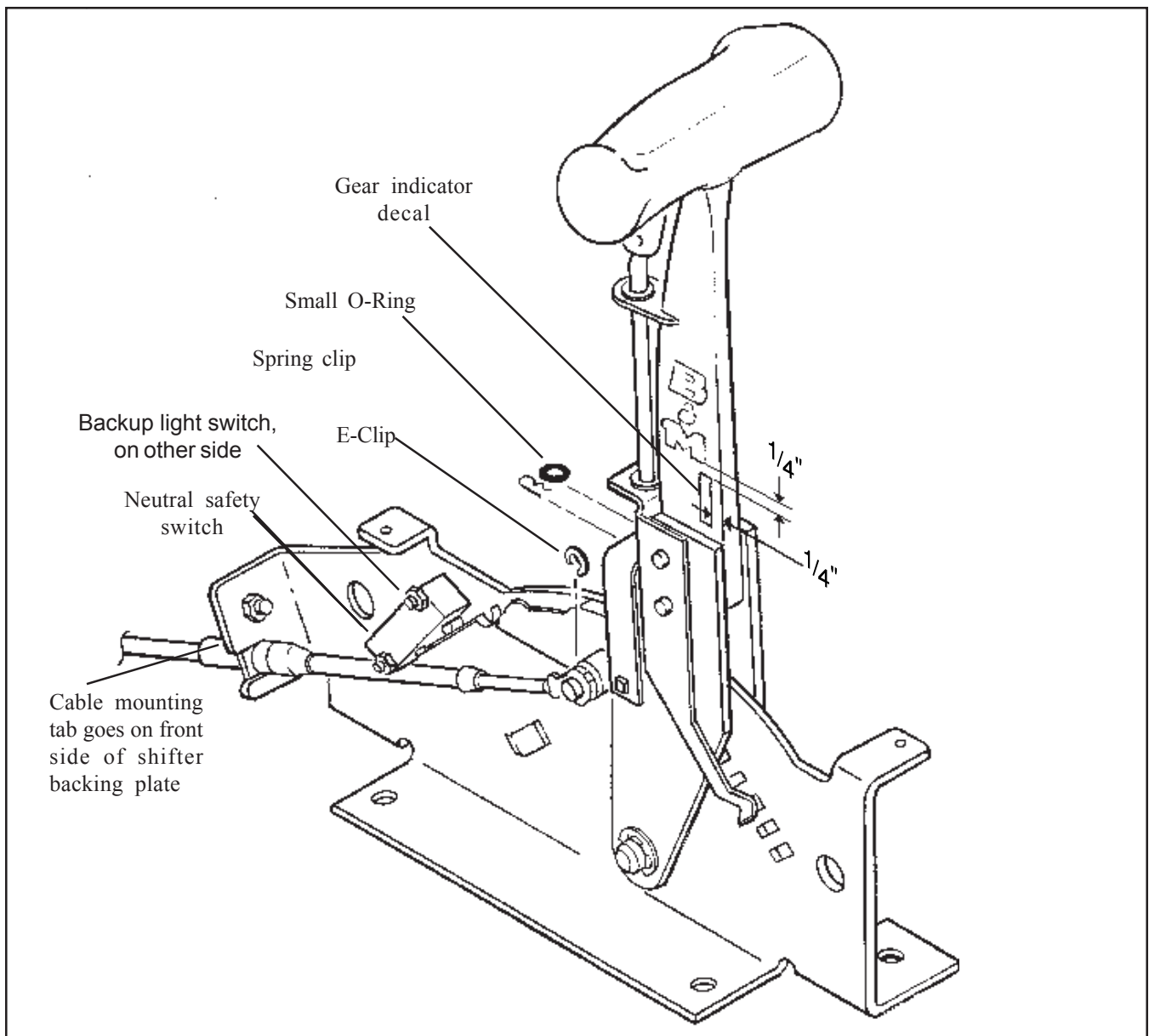

Figure #1

ment tab should be bolted to the outside surface of the shifter base using a 1/4" X 1/2" hex bolt, lock washer and nut. Install the e-clip to secure the cable to the cable pin.

STEP 7. Install the shifter mechanism into the vehicle. Slide the shifter cable through the carpet and the hole in the floor. Bolt the shifter down using four 1/4" hex bolts and nuts. If required use 1/4" washers as shims between the shifter mechanism and the floor to level the shifter. **ROUTE THE CABLE AS SHOWN IN FIGURE #2, AVOID SHARP BENDS WHICH WILL KINK AND DAMAGE THE CABLE.** Use cable clamps or tie wraps to secure the cable housing to chassis to avoid contact with hot engine or exhaust system. For General Motors ve-

hicles go to **Step 8**, for Ford vehicles go to **Step 13**, for Chrysler vehicles go to **Step 19**.

GENERAL MOTORS

STEP 8. If you have not already done so, remove the stock selector lever nut and the selector lever. Discard the stock lever and the stock shifter linkage. Install the **B&M** selector lever in position using the stock selector lever nut (**See Figure #3**). Torque the nut to 23 ft. lbs. The lever should move smoothly from front to rear with a positive click in each gear position.

STEP 9. Remove the two transmission oil pan bolts from the middle of the left side of the oil pan. Install the cable bracket

in position (**See Figure #3**). The bracket must be installed with two spacers between the pan and the bracket. (If your transmission is equipped with a cast aluminum oil pan, these spacers should be omitted however the cable bracket will have to be modified.) Install the two 5/16-18 x 1.00" bolts supplied and tighten to 12-13 ft. lbs. Do not overtighten as this can damage the pan gasket.

STEP 10. Remove the two rubber boots, one large nut, and a large lockwasher from the threaded end of the shifter cable. Route the shifter cable according to **Figure #2**. Avoid sharp bends and route the cable away from hot engine exhaust parts. Slide the end of the cable into the cable bracket, install the lockwasher and large nut over the end of the cable. Posi-

tion the cable so the threaded portion of the cable housing is centered in the cable bracket. Tighten both large nuts to hold the cable in this position. Install the two rubber boots onto the end of the cable.

STEP 11. Move the transmission selector lever by hand to full rear position (Low). Operate the shifter lever to the Low gear position (ratcheted all the way back). Adjust the large nuts on the cable so that the swivel will slide into the **center** hole on the selector lever. Tighten the large nuts completely. Be sure that the swivel will slide freely in and out of the hole in the selector lever. **Note: The shifter will not operate correctly unless the center hole in the shift lever is used.**

Leave the swivel out of the hole and move the selector lever to Park, all the way forward. Also move the shifter to the Park position (all the way forward). Re-insert the swivel into the **center** hole in the selector lever. Check to see that the swivel will slide freely in and out of the **center** hole in the selector lever in this position. If it does not slip in freely, adjust the swivel slightly until it will slip into the hole in the lever.

Move the shifter back to the Low gear position and check that the swivel will still slide easily in and out of the **center** hole in the selector lever. (If you do not use the **center** hole in the lever, it will be impossible to correctly adjust the cable.) Operate the shifter through all the gear

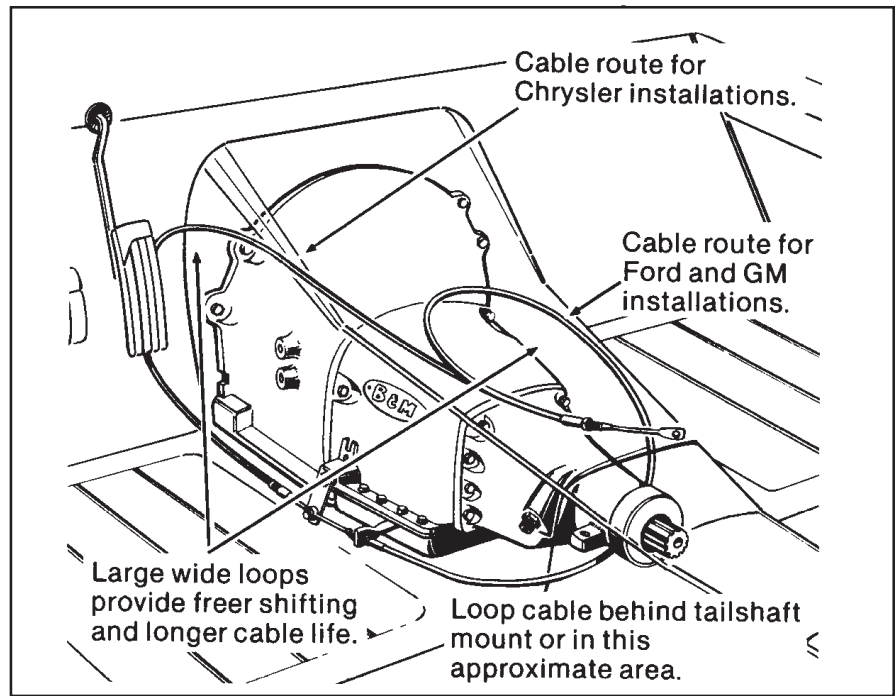

Figure #2

positions. Check to make sure swivel will slide in and out of the **center** selector lever hole in each gear position. The shift cable is now correctly adjusted. Install the cotter key supplied with the shifter into the swivel and spread the key ends.

If you have a problem, **DO NOT FORCE THE SHIFTER**, this will damage the cable, the shifter or the transmission. Simply start at the beginning and check all your steps.

STEP 12. On GM vehicles the neutral safety switch may be located on the shifter (steering column or console), or it may be a mechanical interlock in the steering column that prevents the key from turning to the Start position unless the shifter is in the Park or Neutral position. Identify the type of neutral safety system you have. If the key will not turn to the Start position unless the stock shifter is in Park or Neutral, you have a mechanical interlock, otherwise you have a

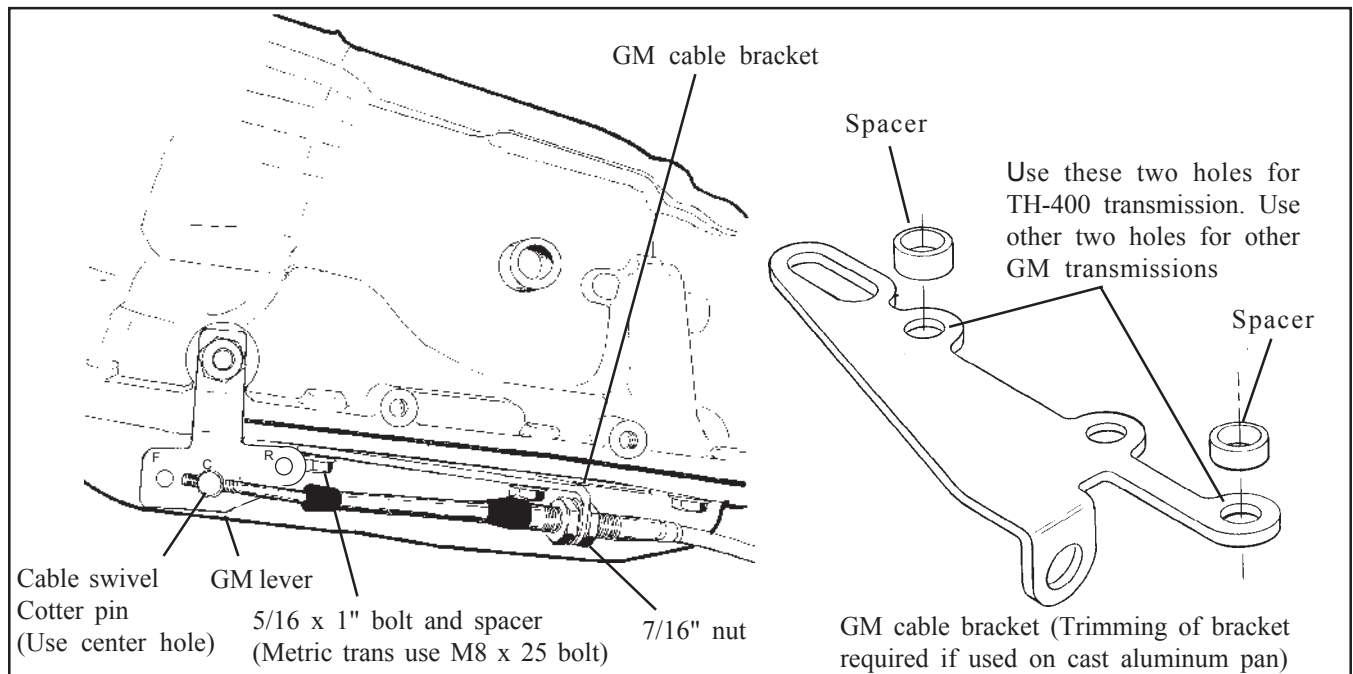

Figure #3

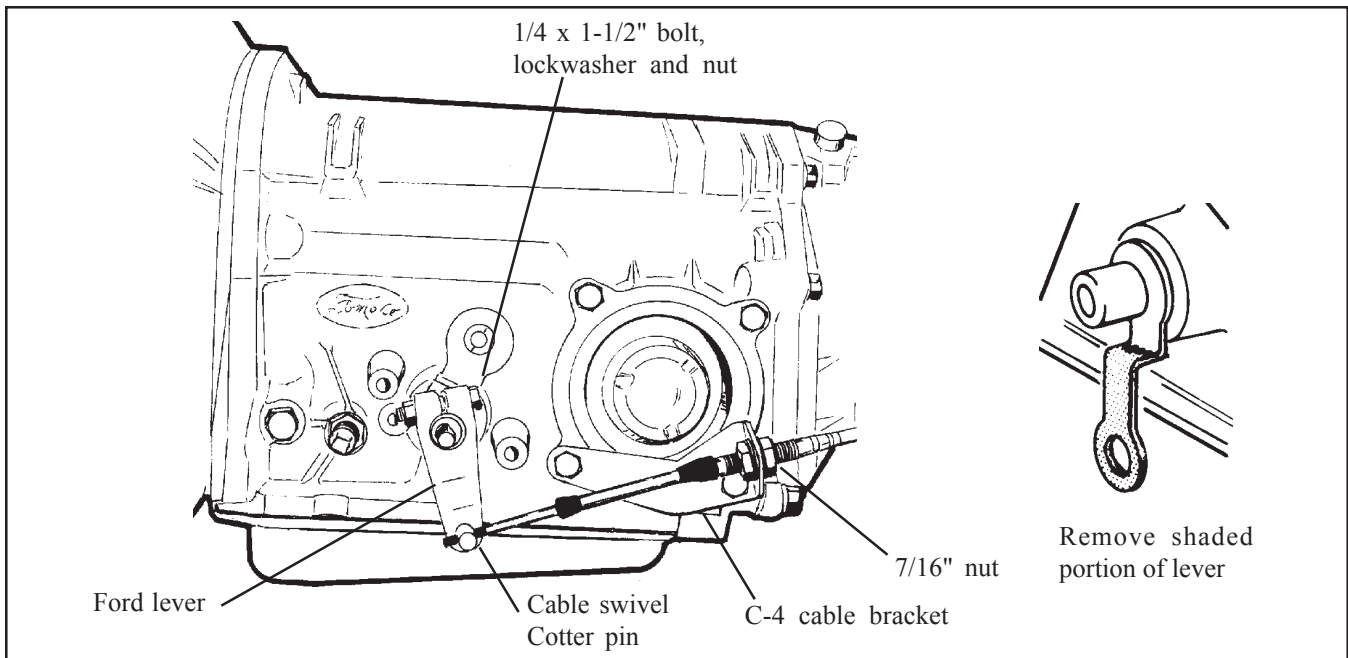

Figure #4

neutral safety switch. If you have a neutral safety switch, locate and identify the neutral safety wires (engine will not crank unless these wires are connected together). With either type, disconnect the battery ground cable to prevent accidental shorts. If you have a neutral safety switch, extend both wires from the GM switch to the switch on the shifter. If you have a mechanical interlock cut the wire that goes from the start position on the ignition switch to the solenoid on the

starter. This wire is usually a 10 or 12 gauge purple wire. Run wires from both ends of the cut wire to the shifter. Put slip on terminals on the ends of the lengthened wire. Crimp the terminals onto the wires using a crimping tool or pliers. Connect the wires to the neutral safety switch on the shifter, on the driver's side of the shifter. Connect the backup light wires to the switch on the other side of the shifter. Tape terminal connections and all other connections to prevent

shorts. Reconnect the battery ground cable, disconnect the coil wire and set the parking brake. Check the switch operation by attempting to start the motor in each shifter position. **The starter must crank only when shifter is in the Park or Neutral position.** Adjust the switches if required. Reconnect the coil wire. Go to **Step 25.**

FORD

STEP 13. If you have not already done so, remove the nut and lockwasher holding the downshift linkage onto the downshift lever shaft. The downshift lever is the outer lever on C-4, C-5 and C-6 transmissions. Pull the lever off the shaft and allow the linkage to hang free. Remove and discard the stock shift linkage rods. Some C-6 and all (late) C-4 and C-5 transmissions have a neutral safety/back up light switch on the transmission shift lever. If your transmission is so equipped, remove the two bolts holding the switch in place and slide it off the shift shaft. Disconnect the switch at the factory plug and discard it.

STEP 14. Install the **B&M** selector lever (See **Figure #4** or **#5**). Note: The **B&M** lever must point downward for proper operation. If the stock shift lever on your transmission points down, you will have to remove the lower part of the stock arm by cutting it off to clear the **B&M** lever (See **Figure #4**). Install the **B&M** selector lever onto the shift shaft of the transmission. Align the selector lever so that when it

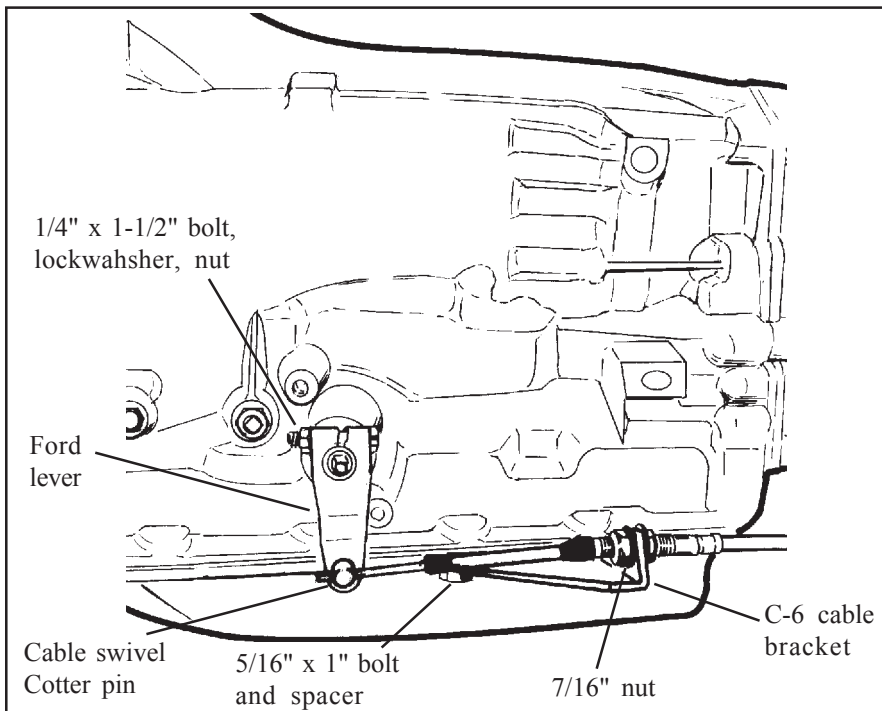

Figure #6

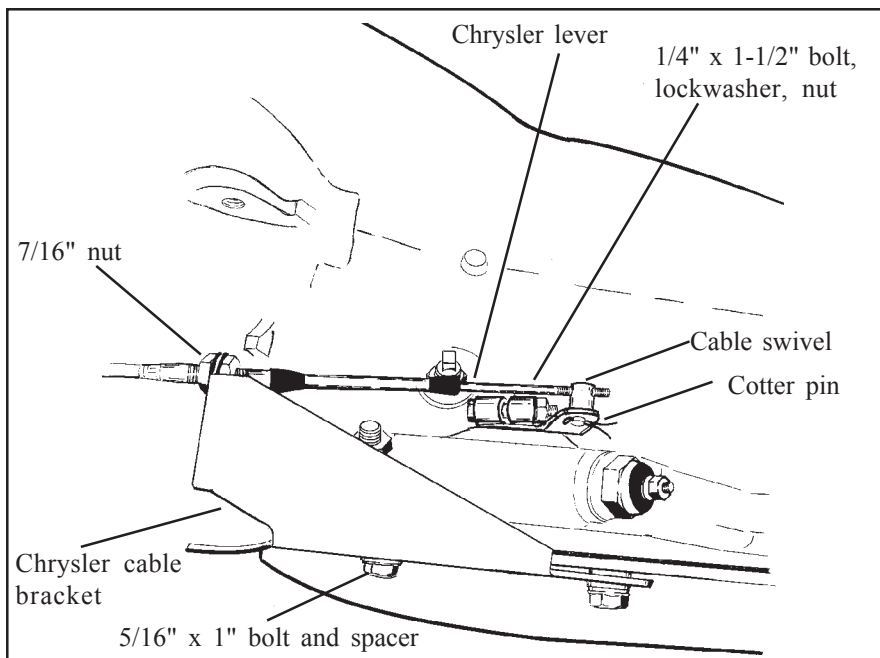

Figure #6

points straight down it travels equal arcs in both directions from the center, then tighten the 1/4"-20 x 1 1/2" pinch bolt and nut. The lever should travel smoothly from front to back with a positive click in each gear position. Make sure the o-ring is in position on the downshift shaft and install the downshift lever in position on the shaft. Install the lockwasher and nut and tighten securely. The downshift lever must operate smoothly. Reconnect the downshift linkage.

STEP 15. Cable bracket installation:

C-4, C-5: Remove the two lower bolts from the rear servo cover. Install the cable bracket in position (See Figure #4). Install the two servo cover bolts as removed and tighten to 12-13 ft. lbs. Do not overtighten as this can distort the servo cover.

C-6: Remove the two transmission oil pan bolts from the left rear corner of the oil pan. Install the cable bracket in position (See Figure #5) with two spacers between the pan and bracket. (If your transmission is equipped with a cast aluminum oil pan, these spacers should be omitted.) Install the two 5/16-18 x 1.00" bolts supplied and tighten 12-13 ft. lbs. Do not overtighten as this can damage the pan gasket.

STEP 16. Remove the two rubber boots, one large nut, and a large lockwasher from the threaded end of the shifter cable. Route the shifter cable according to Figure #2. Avoid sharp bends and route the cable away from hot engine exhaust parts. The cable may be secured up and

out of the way with nylon cable ties. Slide the end of the cable into the cable bracket, install the lockwasher and large nut over the end of the cable. Position the cable so the threaded portion of the cable housing is centered in the cable bracket. Tighten both large nuts to hold the cable in this position. Install the two rubber boots onto end of cable.

STEP 17. Move the transmission selector lever by hand to full rear position (Low). Place the shifter lever to the Low gear position (all the way back). Adjust the large nuts on the cable so that the swivel will slide into the hole on the selector lever. Tighten the large nuts completely. Be sure that the swivel will slide freely in and out of the hole in the selector lever.

With the swivel in the selector lever, move the shifter to the Park position, as far forward as the shifter will go without forcing it. (The shifter has further travel that is used to reach the GM Park position but is not used on Ford transmissions. Trying to force the cable will damage the cable.) The shift lever on the transmission should be all the way forward. Check to see that the swivel will slide freely in and out of the hole in the lever in this position. If it does not slip in freely, adjust the swivel slightly until it will slip into the hole in the lever in both the Low and Park positions. Operate the shifter through all the gear positions. Check to make sure the swivel will slide in and out of the selector lever hole in each gear position. Install the cotter key

supplied with the shifter into the swivel and spread the key ends.

If you have a problem, **DO NOT FORCE THE SHIFTER**, this will damage the cable, the shifter or the transmission. Simply start at the beginning and carefully check all your steps. Reinstall the downshift linkage, tightening the nut securely.

IMPORTANT: Do not force the shifter to over travel into the Park position. This will move the shifter into GM Park position and will damage the cable or transmission.

STEP 18. On Ford vehicles, the neutral safety/backup light switch is located on the transmission (or on the steering column on some early vehicles). If the vehicle has an AOD transmission the neutral safety/backup light switches on the **B&M** shifter will **NOT** be used. The neutral safety/backup light switch on the AOD transmissions will continue to function normally.

On the C-4 and C-5 transmissions it is necessary to completely remove the stock neutral safety/backup light switch in order to install the **B&M** transmission shift lever. On C-4, C-5 and C-6 transmissions, it will be necessary to hook up the neutral safety/backup light switches on the **B&M Z-gate** shifter. Locate and identify the neutral safety (the engine will not crank unless these wires are connected together), and reverse light wires. Disconnect the battery ground cable before beginning to wire the neutral safety and reverse light switches. Reroute the wires to the shifter. Strip 1/4" insulation off the wires and install the supplied slip-on terminals. Crimp the terminals onto the wires using a crimping tool or pliers. Connect the neutral safety wires to the switch on the driver's side of the shifter and the backup light wires to the other switch (See Figure #1). Tape the terminal connections to prevent shorts. Reconnect the battery ground cable, disconnect the coil wire and set the parking brake. Check the switch operation by attempting to start the motor in each shifter position. **The starter must crank only when the shifter is in the Park or Neutral position.** Check the backup light operation when the shifter is shifted to the Reverse position. Adjust the switches if required. Reconnect the coil wire. Go to **Step 25.**

CHRYSLER

STEP 19. If you have not already done

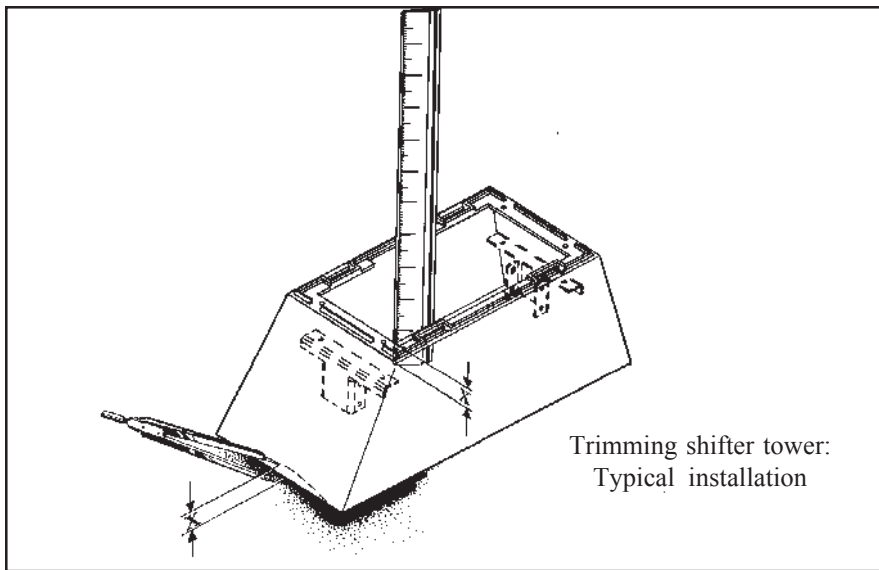

Figure #7

so, loosen the pinch bolt on the throttle lever on the transmission. This is the lever on the small diameter shaft. Pry the lever off with a screwdriver and allow the linkage to hang free. Remove and discard the stock shift lever and the stock shift linkage. Install the **B&M** selector lever in position and tighten the pinch bolt securely (**See Figure #6**). Make sure the lever is not pushed down so far as to touch the transmission case. This will cause the lever to bind on the case. The lever should travel smoothly from front to back with a positive click in each gear position. Install the stock throttle lever in position on the small diameter shaft as removed and tighten the pinch bolt securely. The throttle lever must operate smoothly.

STEP 20. Remove the two transmission oil pan bolts directly below the shift lever. Install the cable bracket in position (**See Figure #6**) with two spacers between the pan and the bracket. (If your transmission is equipped with a cast aluminum oil pan these spacers can be omitted.) Install the two 5/16-18 x 1.00" pan bolts supplied and tighten to 12-13 ft. lbs. Do not overtighten as this can damage the pan gasket.

STEP 21. Remove two rubber boots, one large nut, and a large lockwasher from the threaded end of the shifter cable. Route the shifter cable according to **Figure #2**. Avoid sharp bends and route the cable away from hot engine and exhaust parts. The cable may be secured up out of the way with nylon cable ties. Slide the end of the cable into the cable bracket, install the lockwasher and large nut over the end of the cable. Position the cable

so the threaded portion of the cable housing is centered in the cable bracket. Tighten both large nuts to hold the cable in this position. Install the two rubber boots onto the end of the cable.

STEP 22. Move the transmission selector lever by hand to the full forward position (Low). Place the shifter lever to the Low gear position (ratcheted all the way back). Adjust the large nuts on the cable so that the swivel will slide into the hole on the selector lever. Tighten the large nuts completely. Be sure that the swivel will slide freely in and out of the hole in the selector lever.

With the swivel in the selector lever, move the shifter to the Park position, as far forward as the shifter will go without forcing it. (The shifter has further travel that is used to reach the GM Park position but is not used on Chrysler transmissions. Trying to force the shifter will damage the cable.) The shift lever on the transmission should be all the way back. Check to see that the swivel will slide freely in and out of the hole in the lever in this position. If it does not slip in freely, adjust the swivel slightly until it will slip into the hole in the lever in both the Low and Park positions. Operate the shifter through all the gear positions. Check to make sure swivel will slide in and out of the selector lever hole in each gear position. Install the cotter key supplied with the shifter into the swivel and spread the key ends.

If you have a problem, **DO NOT FORCE THE SHIFTER**, this will damage the cable, the shifter or the transmission. Simply start at the beginning and carefully check all your steps.

TOOL LIST

- 1 Common Screwdriver
- 1 Phillips Screwdriver
- 1 7/16" Wrench
- 1 1/2" Wrench
- 1 9/16" Wrench
- 2 11/16" Wrench
- 1 3/4" Wrench
- 1 Small Adjustable Wrench
- 1 Ratchet Wrench
- 1 7/16" Socket
- 1 1/2" Socket
- 1 Drill Motor
- 1 9/32" Drill Bit
- 1 1" Hole Saw
- 2/4 Jack stands
- 1 0-25 lb.ft. Torque Wrench
- 1 File
- 1 Tin Snips
- 1 Wire Stripper
- 1 Wire crimper
- 1 Tin Snips
- 1 Hammer
- 1 Drift Pin
- 1 Center Punch
- 1 Pliers
- 1 Ruler
- 1 Dividers
- 1 Hack Saw
- 1 Knife
- 1 Electrical Tape
- A/R Nylon Tie Wraps (to secure cable)

IMPORTANT: Do not force the shifter to over travel into the Park position. This will move the shifter into GM Park position and will damage the cable or the transmission.

STEP 23. Check the operation of the throttle linkage again. The linkage must operate smoothly with no bind. All transmissions using automatic valve bodies must have the throttle linkage connected and operating or transmission damage

IMPORTANT

Before installing the T-handle onto the shifter put Loctite on the threads of the stick. The T-Handle may gall on the threads of the stick and make it impossible to remove the handle from the stick. If this occurs it can cause the stick to break if you use excessive force while attempting to remove the knob from the stick.

will result.

STEP 24. Neutral safety/backup light switch.

'66-'68: The neutral safety switch will continue to function normally. It will not be necessary to hook up the neutral safety switch wires on the shifter. Disconnect the battery ground cable before wiring the backup light switch. Locate the original backup light switch on the steering column or the console shifter. Run these wires to the switch on the passenger's side of the **B&M Z-Gate** (See **Figure #1**). Reconnect the ground wire and check the light for proper operation. Adjust the switches on the shifter if required.

'69 and Later: The neutral safety/backup switch is located on the transmission and will continue to function normally. It will not be necessary to connect any wires to the switches on the shifter.

STEP 25. Remove the T-handle, the jam nut and the small trigger knob and rod

from the shifter. To remove the trigger knob and rod remove the spring clip at the bottom of the rod and pull the assembly upwards. There is a small rubber O-Ring between the rod and the "U" shaped stamping, do not lose it (See **Figure #1**).

Install the gear indicator tape on the side of the stick using the dimensions given in **Figure #1**.

Place the black tower over the shifter mechanism until the bottom edge of the tower touches the floor. Hold the tower level to the shifter with the bottom of the tower touching the highest surface on the floor it will come into contact with (See **Figure #7**). Use a ruler to measure the distance X from the underside of the tower to the tower mounting brackets on the shifter mechanism.

STEP 26. Set a pair of dividers at the distance X, measured in **Step 25**. Hold the tower level to the shifter mechanism with the bottom of the tower touching the

highest surface on the floor it will come into contact with. Holding the tower in position, place one leg of the divider against the floor while the other touches the tower (See **Figure #7**). Using the dividers, scribe a line around the tower that follows the contour of the floorboard. Remove the tower and trim at the scribe line using tin snips. Once the tower is properly trimmed, install it using two #10 self tapping screws.

STEP 27. Slip the chrome cover over the shifter stick. Replace the trigger rod assembly and reinstall the spring clip. Replace the small rubber O-Ring between the rod and the "U" shaped stamping (See **Figure #1**). Press the cover tabs into the slots in the tower to snap it in place. Move the shifter through the full travel and notice the clearance in the cover slot. If the stick rubs the cover, either the cover or the tower is improperly installed. Replace the T-handle and the jam nut.

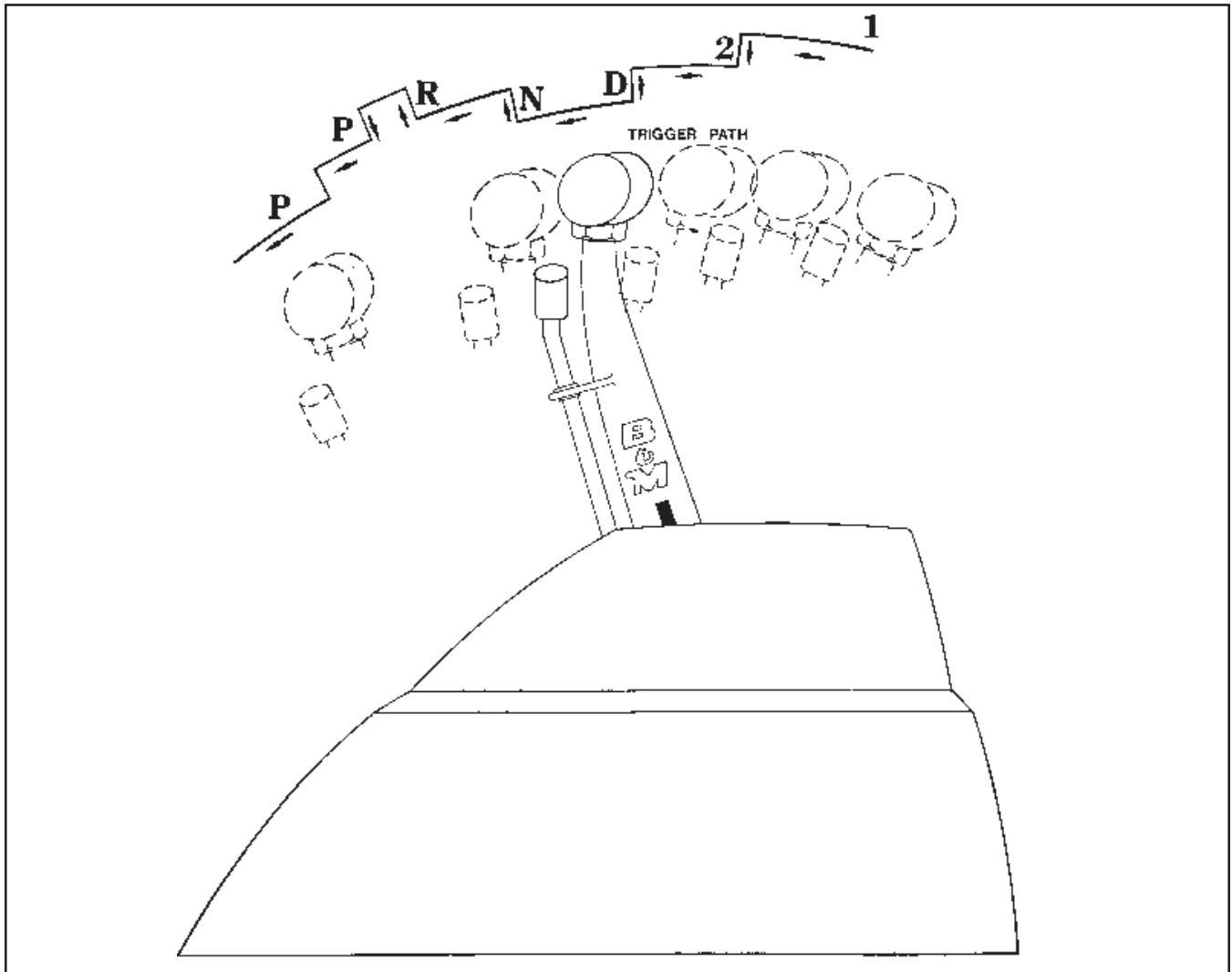

Figure #8

OPERATION

Operation of the **B&M Z-gate** shifter is quite simple. After you run it through the gate positions two or three times, you will find it easy to use.

Figure #8 shows the stick and trigger positions that correspond to various transmission positions. The indicator decal will line up with the correct gear positions on the chrome cover. Study the illustration and operate the shifter to all positions by lifting or dropping the trig-

ger and moving the stick. Note: There are two Park positions on the shifter. The one closest to Reverse is used on Ford and Chrysler vehicles. The forward one is used on G.M. vehicles.

The stick will move between Neutral and Drive positions without lifting the trigger.

To engage Reverse from Neutral, lift the trigger slightly and push the stick forward.

To engage Park from Neutral or Reverse, lift the trigger fully and push the

stick forward until it stops, then release the trigger. The shifter will lock in Park position and you must lift the trigger to Reverse or Neutral.

When downshifting, Drive to 2 or 2 to 1 you must lift the trigger and pull the stick back.

When upshifting, 1 to 2 or 2 to Drive, moving the stick with a quick, firm push will cause the trigger to stop in each gear position. Moving the stick slowly will allow the trigger to slide through the gears without stopping.

CHECKLIST

- | | | |
|--|---|--|
| <ul style="list-style-type: none"> ___ Locking steering column lever is permanently fastened in the full up position. Step 1. ___ Shifter is convenient to reach and has ample room for your hand in both park and low gear. Step 2. ___ Carpet covers floorboard holes. Step 4. ___ Cable is securely fastened to the shifter and held with E-Clip. Step 6. ___ Shifter is securely mounted to floorboard. Step 8. ___ Shifter cable is clear of exhaust system, engine and any moving parts. Step 7. | <ul style="list-style-type: none"> ___ Throttle lever and shift lever are tight on transmission. GM step 9, Ford Step 14, Chrysler Step 20. ___ Oil pan bolts are tightened to 12-13 ft. lbs. GM Step 10, Ford Step 16, Chrysler Step 21. ___ Shifter is properly adjusted. Cable boots are installed, cable nuts are tightened and swivel is secured with cotter key. GM Step 11, Ford Step 17, Chrysler Step 22. ___ The neutral safety switch is connected and properly adjusted to prevent engine starts in drive gears and reverse. GM Step 12, Ford Step 18, Chrysler not required. | <ul style="list-style-type: none"> ___ There is no debris in the shifter mechanism. ___ Tower is trimmed and securely held with two screws. Step 26. ___ Chrome cover snapped into place and shift position indicator correctly aligned. Step 27. ___ Shifter moves freely in all positions as described in Shifter Operation. ___ If your shifter is not working properly do not attempt to drive your car. Make sure you have followed all instructions. If the shifter is broken or defective return it to your B&M dealer. |
|--|---|--|

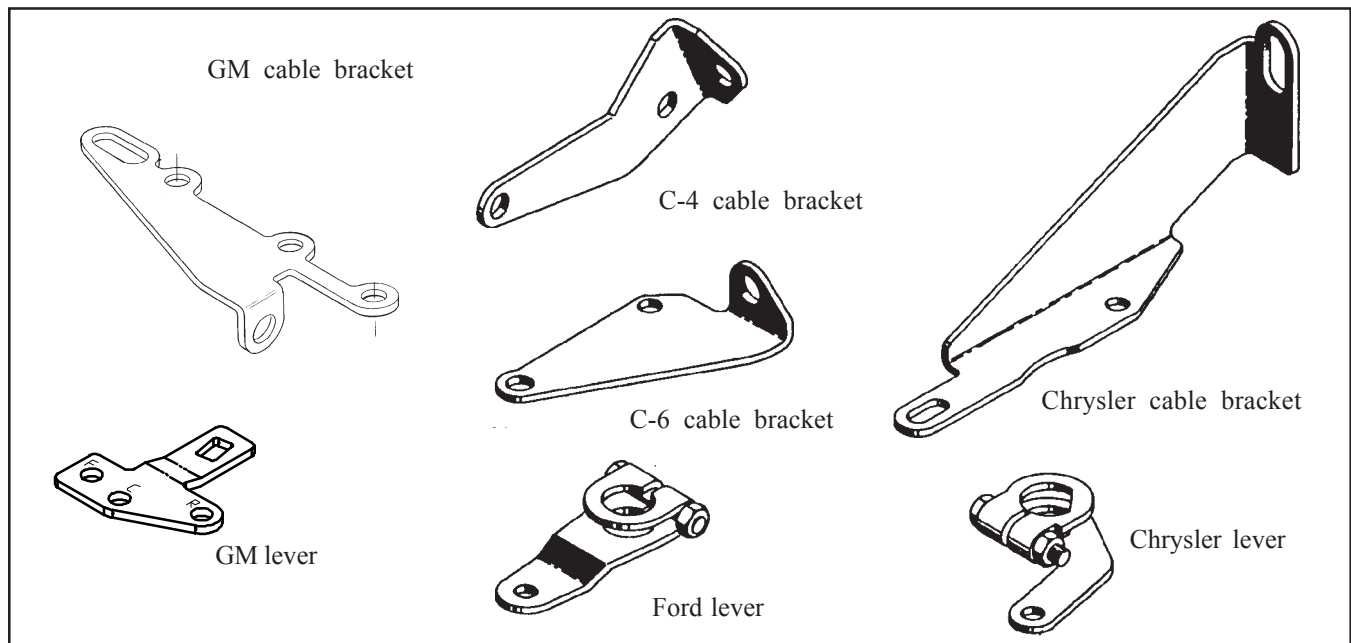

Cable brackets and levers