



Installation Instructions

Precision Sport Shifter

1997 and up C5 & C6

Chevrolet Corvette

©2006, 2005 by B&M Racing and Performance Products

This **B&M Precision Sport Shifter** has been designed to work on most 1997 and up C5 & C6 Corvette model vehicles. It has been engineered to greatly reduce shift throw and improve shifter feel. Check the parts and tools lists at the beginning of these instructions for the supplied parts and the tools required to install your **B&M Precision Sport Shifter**. Installation of this **B&M Precision Sport Shifter** can be accomplished by anyone with minimal mechanical experience.

INTRODUCTION

This **B&M Precision Sport Shifter** can be installed in less than an hour and a half by carefully following the instructions. Read all instructions first to familiarize yourself with the parts, tools, and procedures. This kit contains all the parts necessary to install the shifter.

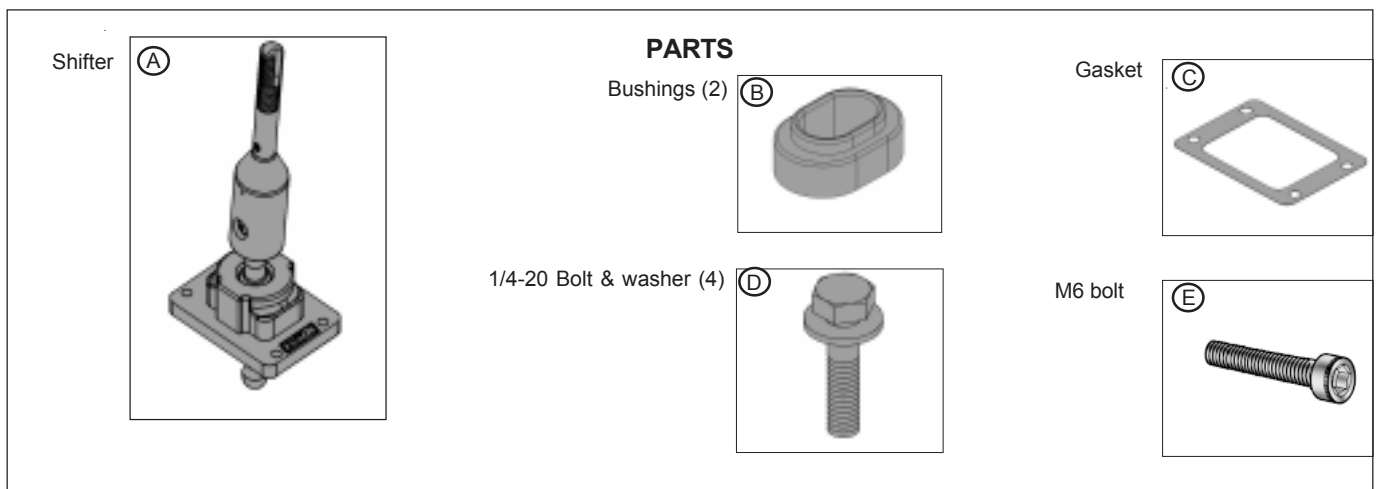

TOOLS

Socket(7, 10mm
7/16" 11/32" & 3/8")



Small Flatblade
Screwdriver



Vise Grips



Needlenose pliers

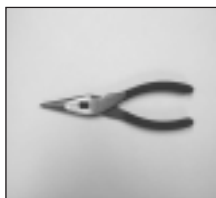

Socket Drive



Channel Locks



Punch



Allen wrench (3/32")



Extension



T-15 & T-40



Hammer



C-5 CORVETTE DISASSEMBLY GOTO STEP 10 FOR C-6 DISASSEMBLY

STEP 1. Pry up on rear of gear shift insert and remove.
TOOL: Small Flatblade Screwdriver



STEP 2. Remove small metal insert.
TOOL: Vise grips



STEP 3. Remove knob.



STEP 4. Remove traction control panel and disconnect all wires.
TOOL: Small Flatblade Screwdriver



STEP 5. Remove (2) retaining nuts and wire connectors.
TOOLS: Socket(10 mm), Drive, and Extension.



STEP 6. Remove panel next to ignition key (temperature sensor) and remove screw.
TOOLS: Small Flatblade Screwdriver, Ratchet, Extension & T-15



STEP 7. Remove bolts beside lighter and under ashtray.
TOOLS: Ratchet, Extension & T-15



STEP 8. Remove small inserts at rear of rear center console and remove (2) nuts.
TOOLS: Small Flatblade Screwdriver, Ratchet, Extension & T-15



STEP 9. Slide rear center console back enough to remove front center console. Remove front center console.

FOR C-5 GOTO STEP 19



C - 6 DISASSEMBLY

STEP 10. Remove panel for passenger air bag and remove module.
TOOLS: Small Flatblade Screwdriver



STEP 11. Remove (1) nut holding down console.
TOOLS: Ratchet, Extension & Socket (10mm)



STEP 12. Remove (4) bolts securing arm rest and remove arm rest.
TOOLS: Ratchet, Extension & T-15



STEP 13. Remove (2) screws under passenger airbag panel.
TOOLS: Ratchet, Extension & Socket (7mm)



STEP 14. Pull up on sleeve around emergency brake uncovering bolts attaching center console.



STEP 15. Remove (2) bolts holding down front center console.
TOOLS: Ratchet, Extension & Socket (7mm)



STEP 16. Remove passenger side panel and lift up on front center console.



STEP 17. Lift leather boot out of console.



STEP 18. Remove screw securing knob and lift out front center console. Be sure to remove connector wires.
TOOL: Ratchet, Extension & T-20



STEP 19. Remove foam and (4) nuts securing rubber.
TOOLS:Ratchet, Extension & Socket (10mm)



STEP 20. Remove (4) bolts securing shifter and remove from vehicle.
NOTE: Shifter shown out of car for clarity only.



STEP 21. Remove pivot cup from bottom of stock shifter.
TOOLS: Channel Locks



STEP 22. Install plastic pivot cup onto bottom of B&M shifter.



STEP 23. Remove bolts securing shifter base to vehicle.
TOOLS: Ratchet, Extension & T-40

NOTE: THIS STEP IS NOT NECESSARY ON C-5 Z06
MODEL VEHICLES AS IT IS ALREADY SOLID
MOUNTED. ALSO NOTE THAT THIS STEP IS
OPTIONAL AND WILL TRANSMIT MORE
NOISE AND VIBRATION THAN RUBBER
BUSHINGS.



STEP 24. Remove stock rubber bushings.
TOOL: Small Flatblade Screwdriver



STEP 25. Install bushing underneath housing as shown.



STEP 26. Install bolts securing shifter base to vehicle.
TOOLS: Ratchet, Extension & T-40



STEP 27. Remove old rubber gasket completely and install new gasket.
TOOL: Flathead screwdriver or gasket scraper



STEP 28. Install B&M shifter, for C-5 slot in shifter should be toward rear of car.
For C-6, unassemble top of shifter and rotate 180° so that slot faces forward and reassemble. (see diagram)
Test shifter through all gears.
TOOLS: Ratchet, Extension, Socket (7/16")
11/32" socket & 3/32" Allen.

SLOT

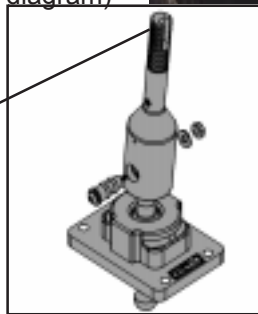

STEP 29. Reinstall foam and (4) nuts securing rubber.
TOOLS: Ratchet, Extension & Socket (10mm)

GO TO STEP 39 FOR C-5 ASSEMBLY



C-6 ASSEMBLY

STEP 30. Reinstall front center console and install M6 screw securing knob. Be sure to reinstall connector wires.
TOOL: Ratchet, Extension & T-20



STEP 31. Reinstall leather boot into console.



STEP 32. Reinstall passenger side panel and lift up on front center console.



STEP 33. Reinstall (2) bolts holding down front center console.
TOOLS: Ratchet, Extension & Socket (7mm)



STEP 34. Reinstall sleeve around emergency brake.



STEP 35. Reinstall (1) nut holding down console.
TOOLS: Ratchet, Extension & Socket (10mm)



STEP 36. Reinstall (2) screws under passenger airbag panel.
TOOLS: Ratchet, Extension & Socket (7mm)



STEP 37. Reinstall panel for passenger air bag and reinstall module.
TOOLS: Small Flatblade Screwdriver



STEP 38. Reinstall (4) bolts securing arm rest and.
TOOLS: Ratchet, Extension & T-15



C - 5 ASSEMBLY

STEP 39. Reinstall front center console and slide rear center console into place.



STEP 40. Reinstall (2) nuts and small inserts at rear of rear center console.
TOOLS: Small Flatblade Screwdriver Ratchet, Extension & Socket (10mm)



STEP 41. Reinstall bolts beside lighter and under ashtray.
TOOLS: Ratchet, Extension & T-15



STEP 42. Reinstall screw next to ignition key and replace panel.
TOOLS: Ratchet, Extension & T-15



STEP 43. Reinstall (2) retaining nuts and wire connectors.
TOOLS: Socket(10 mm), Drive, and Extension.



STEP 44. Reinstall traction control panel and connect all wires.
TOOL: Small Flatblade Screwdriver



STEP 45. Reinstall knob.



STEP 46. Reinstall metal insert into knob and shift pattern indicator.

TOOLS: Hammer & Punch

Be sure all the parts have been securely tightened and shifter engages into each gear. ENJOY!!



Manual Shift Knobs

B&M's **Manual Shift Knobs** are perfect when style and performance matter. Ergonomically correct and made from the highest grade materials, these sturdy knobs incorporate the latest styling as well as distinctive design. Each knob is designed to fit most vehicles equipped with a floor mounted manual gearbox stick. B&M knobs are mounted and tightly secured via an innovative stick locating/locking method that keeps the mounting method invisible. Fit up to 9/16" or 14mm thread diameter (except where noted).



These Hi-tech **Button Knobs** can be used to control any 12-volt function in your vehicle. They feature a momentary switch in a billet aluminum anodized knob. Suitable for nitrous or line lock systems. Fits metric thread sizes: M16x1.5, M12x1.75, M12x1.25, M10x1.5 and M10x1.25 shifter sticks. Knob measures 3.75" in height.

B&M *Racing & Performance Products*