



INSTALLATION INSTRUCTIONS FOR
QUICKSILVER™
UNIVERSAL SHIFTER
Part Nos. 80683 & 81683
 for the automatic transmissions listed below

INTRODUCTION

The triggerless, bootless QuickSilver™ is B&M's cleanest-looking shifter. With its smooth, ratchet-shifting action, you won't miss a shift. QuickSilver is compatible with both standard- and reverse-pattern transmissions, and its "one-hand" reverse lockout mechanism meets NHRA and IHRA safety requirements.

Before starting, take the time to read and understand these instructions.

Also, use the parts list to verify your kit's contents. In the unlikely event that any parts are missing, please contact B&M Technical Support for replacements.

NOTE: Some hardware bags are shared by similar B&M shifters. Your bag may include extra items that are used on other shifters, but the parts list below shows all the parts required for this shifter.

REQUIRED SUPPLIES

- Medium strength thread-locking fluid (Permatex Blue or equivalent)

APPLICABLE TRANSMISSIONS

This shifter kit **includes all cable brackets and selector levers** required for use with the following automatic transmissions:

MANUFACTURER	TRANSMISSION
Chrysler (1966+) and AMC (1972+)	A727 / A518 and A904 / A500
Ford	C4 / C5 and C6
GM (Turbo-Hydramatic)	TH200, TH250, TH350, TH400, 200-4R and 700R4 / 4L60
GM (electronic, <i>without</i> PRNDL switch)	4L60E, 4L65E, 4L70E, 4L75E, 4L80E and 4L85E

The shifter can also be used with the following transmissions, **with the applicable B&M install kits** (sold separately).

MANUFACTURER	TRANSMISSION	INSTALL KIT
Ford	AOD	40496
Ford	AODE and 4R70W	40504
Ford	E40D and 4R100	40505
GM (electronic, <i>with</i> PRNDL switch)	4L60E, 4L65E, 4L70E, 4L75E, 4L80E and 4L85E	70499

NOTE: Additional instructions for these transmissions are included with their respective install kits.

NOTES

- Installation requires better-than-average mechanical knowledge and skills. If this job is beyond your abilities, seek the services of a qualified technician.
- The shifter mechanism is precision-assembled at our factory. **Any modification or disassembly of the shifter will void its warranty, and can cause it to malfunction.** Disassemble items **only** where specified in the instructions.
- Installation of this shifter may require modification or complete removal of your vehicle's console, depending on the space available in your vehicle.
- The shifter cable in this kit is 5 feet long. Different length shifter cables are available separately from B&M, if required.
- The shifter-transmission positions mentioned throughout these instructions apply to standard-pattern transmissions (for example, P-R-N-D-2-L). Transmissions with reverse-pattern (P-R-N-L-2-D) manual valve bodies will alter your shifter-transmission positions accordingly.

PARTS LIST



DESCRIPTION	QTY
KNOB, SHIFTER	1
SHIFTER ASSEMBLY, QUICKSILVER	1
WASHER, FLAT 1/4"	12
BOLT, 1/4-20 x 1-1/4"	4
PIN, LIMITER	1
E-CLIP, 1/4" I.D.	3
CABLE, SHIFTER, 5'	1
BOLT, 1/4-20 x 1/2"	1
NUT, HEX 1/4-20	6
MICRO-SWITCH	2
SCREW, 4-40 x 1-1/4", SLOTTED, PAN HEAD	2
WASHER, SPLIT LOCK #4	2
NUT, HEX 4-40	2
WASHER, SPLIT LOCK 1/4"	5
SELECTOR LEVER, CHRYSLER / AMC	1
CABLE BRACKET, CHRYSLER / AMC	1
SELECTOR LEVER, FORD C4 / C5 and C6	1
CABLE BRACKET, FORD C4 / C5	1
CABLE BRACKET, FORD C6	1
SELECTOR LEVER, GM TH & ELECTRONIC	1
CABLE BRKT, GM TH & ELECTRONIC (NO PRNDL SWITCH)	1
BOLT, 1/4-20 x 1-1/2"	1
BOLT, 5/16-18 x 1"	2
BOLT, M8-1.25 x 25	2
WASHER, FLAT 5/16"	2
SPACER, 7/16" I.D. x 1/4" L	2
JAM NUT, 10-32 (COMES INSTALLED ON CABLE END)	1
SWIVEL, CABLE	1
PIN, COTTER 1/16" x 1"	1
WIRE TERMINAL, FEMALE, 1/4", BLUE, 16-14 AWG	4
TOWER, SHIFTER	1
SCREW, #10 x 3/8", THREAD-FORMING FOR PLASTIC	1
SOCKET, INDICATOR BULB	1
LIGHT BULB, INDICATOR	1
BOOT, SHIFTER	1
INDICATOR WINDOW, 3-SPEED	1
INDICATOR WINDOW, 4-SPEED	1
COVER, QUICKSILVER TOWER	1
SCREW, 10-32 x 3/4", SELF-TAPPING, PHILLIPS, PAN HEAD	4
INSERT, SHIFT KNOB	1

SAFETY WARNINGS

- **WORK SAFELY!** For maximum safety, perform this installation on a clean, level surface, with the engine turned off. Chock the wheels to prevent vehicle movement. To avoid bodily injury or vehicle damage, do not begin work until you are confident that the vehicle is safely secured and will not move.
- **AVOID SERIOUS INJURY OR DEATH BY CRUSHING!** If you have to raise the vehicle to work under it, securely support it on a lift or jack stands. **NEVER work under a vehicle that is supported only by jacks!**
- **WARNING: This B&M performance shifter uses a cable to shift the transmission only; it is NOT intended or designed to operate a locking steering column! If your vehicle has a locking steering column, it must be modified or disabled to prevent the steering from unintentionally locking up while driving.** If you are not comfortable making this modification, or if you don't understand this warning, seek the services of a qualified technician for the safe installation of this shifter.

INSTALLATION

1. Remove the stock shift linkage.

Column Shifters: Remove all rods, levers or cables from the column and the transmission. Place the column shift lever in the PARK position. Remove the pin holding the shift lever in the column and remove the lever assembly. If your vehicle is equipped with a locking steering column, secure the column lock lever in the full up position. (**See WARNING re. locking steering columns, above.**)

Console Shifters: Remove the shifter mechanism from the console. Disconnect the rod or the cable from the transmission. Remove the cable bracket if equipped. If there is a cable or linkage from the console shifter or transmission to the steering column lock, it must be secured in the PARK position as described above.

Switch Wires: While removing the stock shift linkage, look for neutral safety and / or backup light switches and wiring. (These mechanisms vary on different vehicles. **See the installation section for your vehicle for details.**) Label any such wires to simplify installation.

- ### 2. Locate the B&M shifter in your vehicle.
- Pull the carpet (if any) away from the floorboard where the shifter will be mounted. If the vehicle has a bench type seat, move the seat to the full forward position. Temporarily thread the **knob** onto the **shifter**, then place the shifter on the floor, locating it for ease and convenience of operation. **For minimum clearance at the tower, the shifter's rear mount hole must be at least 1-3/4" from the seat when the seat is in the**

full forward position. Make sure the shifter knob will clear both the dash and the seat when the lever is pushed forward and rearward. When you are satisfied with the position of the shifter, mark the location of its four mount holes on the floor.

- 3. Drill the mount holes.** Drill four 9/32" mount holes through the floor. Put the shifter in place. Shim it to level (if necessary) using the twelve **1/4" flat washers** between the shifter and the floor, and temporarily hold it in place with the four **1/4-20 x 1-1/4" bolts**.
- 4. Drill the cable hole.** Mark the center for the shifter cable hole 3-1/2" forward of the front edge of the left shifter base (see Step 7 photo). Drill or cut the 1-1/2" diameter cable hole through the floor.

NOTE: If your vehicle's floor is too thin to properly support the shifter mechanism when bolted to it, fabricate a sheet metal stiffener to reinforce it.

- 5. Return the carpet** to its original position (but do not secure it yet). Cut holes in the carpet for the shifter mount holes, and cut a 1-1/2" slit for the cable. (**Do not use a drill bit to make the holes in the carpet.**)

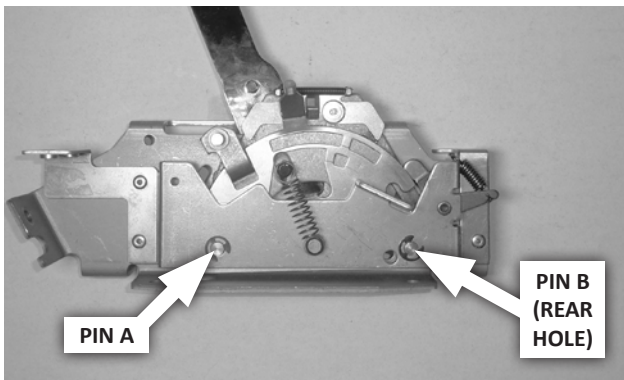

- 6. Configure the park and speed limiter pins for your application** as shown in the photo and table. (Each pin is secured with two 1/4" e-clips.)

TRANSMISSION	PARK LIMITER PIN A	SPEED LIMITER PIN B
All Chrysler / AMC and Ford	Installed	Installed in rear hole
GM 3-speeds	Removed	Installed in rear hole
GM 4-speeds	Removed	Removed

NOTES

- The **park limiter pin must be used with Chrysler / AMC and Ford transmissions**, to avoid stretching the shifter cable. (Selector lever travel from REVERSE to PARK is longer on GM transmissions than on Chrysler and Ford transmissions.)
- Selector levers on **all Chrysler / AMC and Ford transmissions** (whether 3- or 4-speed) **have just 3 forward speed positions.**

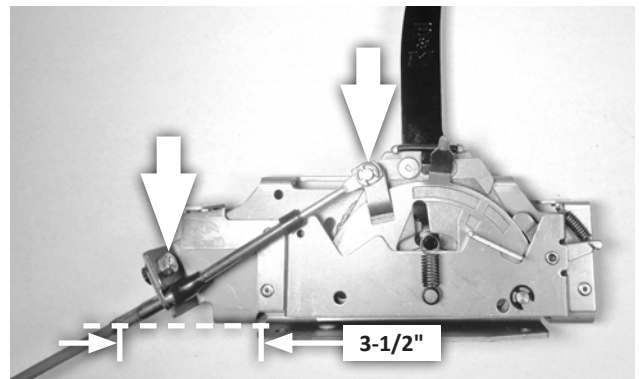

- 7. Assemble the cable and shifter.** Secure the **cable eye** to the shifter pin with a **1/4" I.D. e-clip**. Then secure the cable's mount tab to the **outside surface** of the shifter base with the **1/4-20 x 1/2" bolt** and a **1/4" nut** (apply **medium strength thread-locking fluid** to the bolt).

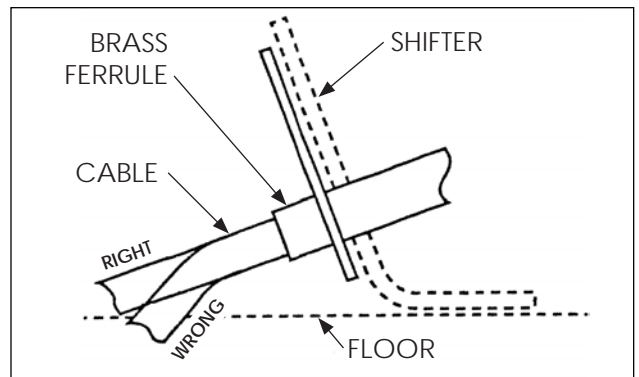

CAUTION: Do not kink the cable anywhere along its length, or it will lock up. The cable should be kept straight for at least 2" after it leaves the brass ferrule at each end.

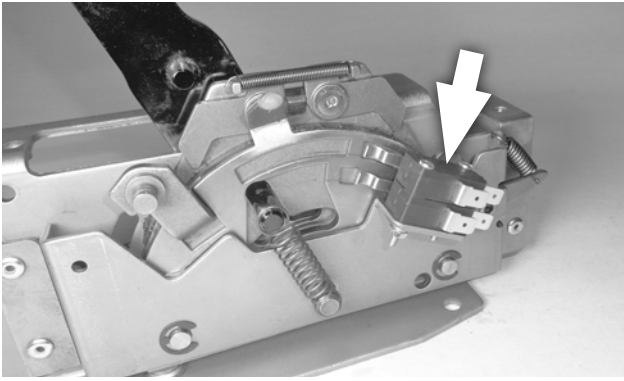

8. Install the two micro-switches on the shifter mechanism as shown, using the two #4-40 × 1-1/4" screws, lock washers and nuts.

CAUTION: Tighten the fasteners only until the lock washers are squeezed flat. Over-tightening may crack the switch housings.

While tightening the fasteners, check placement of the switches to verify that:

- the **neutral safety (bottom) switch** closes in NEUTRAL and PARK only; and
- the **backup light (top) switch** closes in REVERSE only.

NOTES

- Refer to the "Operation" section to understand the positions of the shift lever.
- The switches' mount holes normally allow the required positioning for proper actuation. However, if necessary, the switch arms may be carefully bent.

9. Install the shifter in the vehicle. Slide the cable through the carpet and the hole in the floor, then bolt the shifter to the floor using the four 1/4-20 × 1-1/4" bolts, lock washers and nuts (and using the twelve 1/4" flat washers as leveling shims, if required). Do not bend the shifter mount tabs

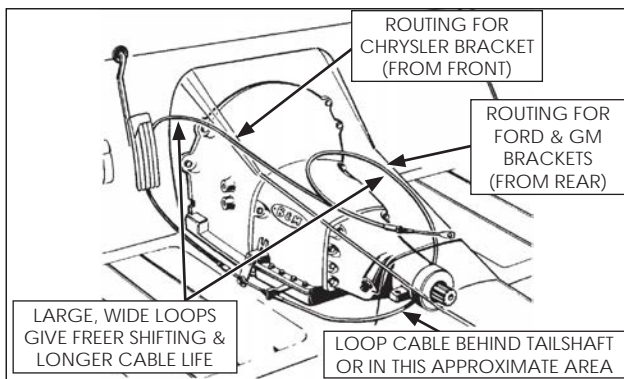

10. Route the cable approximately as shown, based on your application. Avoid any sharp bends which may kink or otherwise damage the cable. Seal the cable hole shut to keep exhaust fumes, water, etc. out of the passenger

compartment. Use clamps and / or cable ties (customer supplied) to secure the cable housing in such a way as to prevent contact with the exhaust system, engine, or any moving parts.

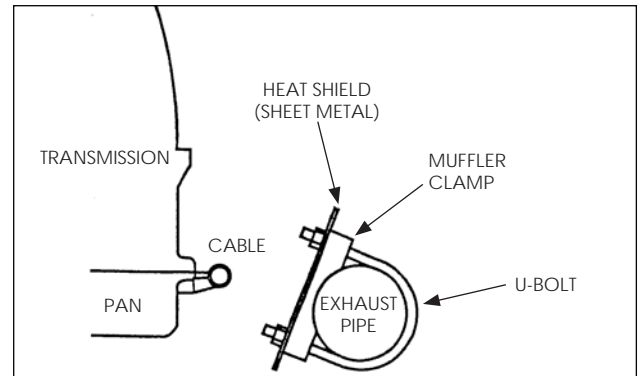

CAUTION: Heat will severely damage the shift cable, causing the housing to melt or become brittle. If the cable must be routed near exhaust system components, fabricate a heat shield. Do not wrap the cable, as this retains heat.

NOTE: The instruction photos show transmissions on a work bench, not installed in vehicles.

For CHRYSLER / AMC applications, go to STEP 11.

For FORD applications, go to STEP 26.

For GM applications, go to STEP 43.

CHRYSLER / AMC

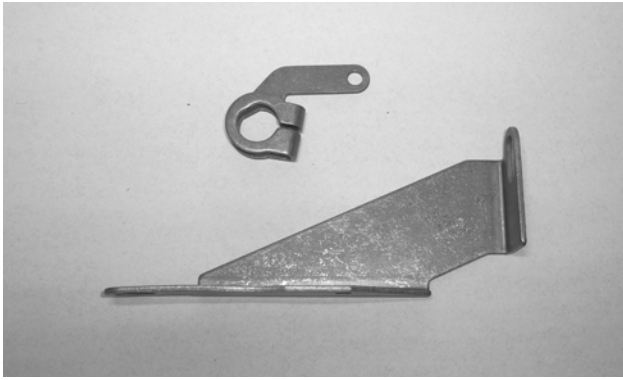

11. Get the Chrysler / AMC selector lever and cable bracket from the parts kit.

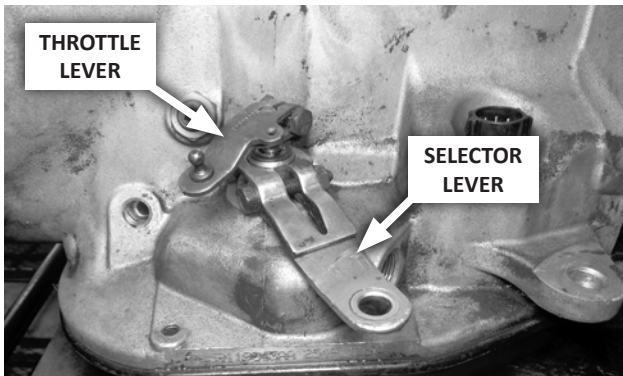

12. **Disconnect stock controls:** Loosen the throttle lever pinch bolt, remove the lever from its shaft, and carefully move the lever and linkage aside, allowing them to hang free. Remove and discard the stock selector lever and shift linkage.

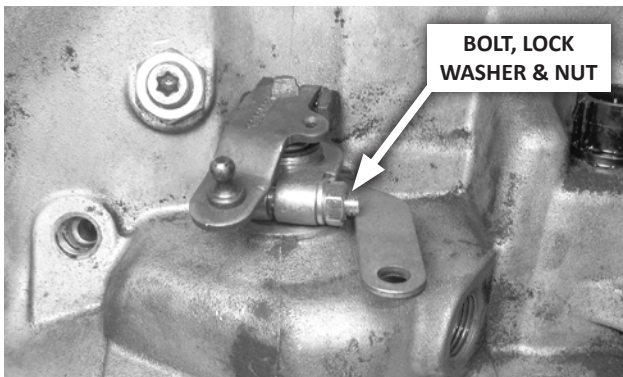

13. Install the B&M selector lever using the $1/4-20 \times 1-1/2$ " bolt, and a $1/4$ " lock washer and nut. Be sure the lever is not pushed down against the transmission case, which could cause binding. The lever should travel smoothly back and forth, with a positive "click" in each detent. Then reinstall the throttle lever and linkage, tighten its pinch bolt securely, and check for smooth operation.

CAUTION: To avoid stripping out your transmission's bolt holes, use the correct bracket bolts. This kit includes both SAE and metric bracket bolts. (The metric bolts have finer threads.) To choose the correct kit bolts, compare them to the stock bolts you removed.

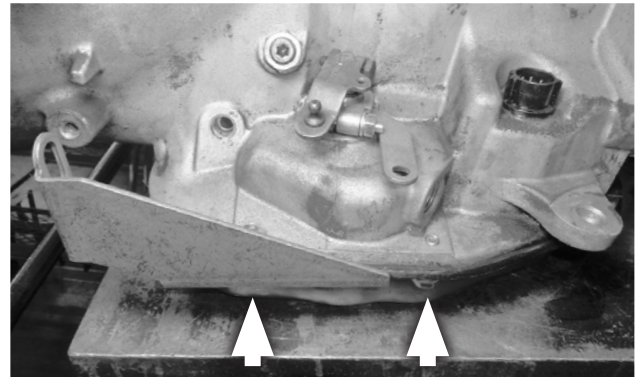

14. Install the cable bracket at the two pan bolt holes directly below the selector lever, using the two $5/16-18 \times 1$ " bolts and flat washers. For stamped sheet-metal (stock) pans, use the two spacers between the pan and bracket. (Spacers are not used with cast aluminum pans.) Tighten the bolts to 12-13 ft-lbs torque.

CAUTION: Do not over-tighten the bolts, as this can damage the pan gasket.

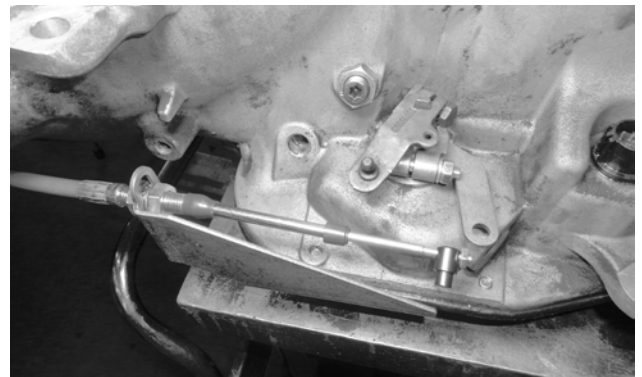

15. **Attach the shifter cable to the cable bracket:** First remove the small jam nut, two plastic dust boots, and one large nut and lock washer from the cable. Then insert the cable through the cable bracket, reinstall the lock washer and nut on the cable (loosely, to allow room for adjustment), and reinstall the two dust boots.

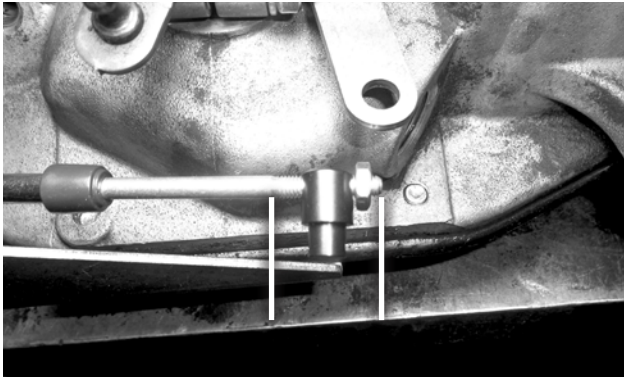

16. Thread the swivel onto the cable to about the middle of the threaded section, then reinstall (but do not tighten) the jam nut.

NOTE: Before proceeding, verify that the park and speed limiter pins are configured as described at Step 6.

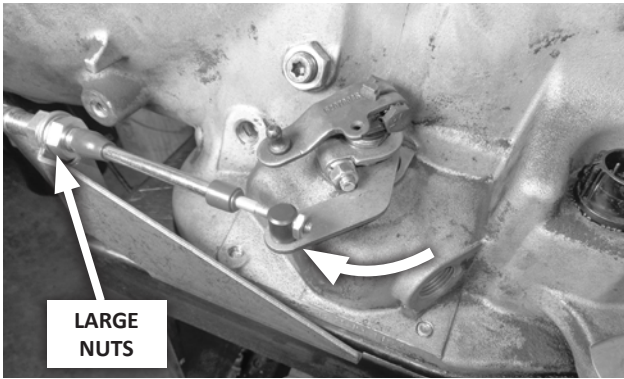

17. Manually move the selector lever to the LOW (full-forward) detent. Move the shifter handle to the LOW position (ratcheted all the way back). Adjust the large cable nuts until the swivel slides freely in and out of the hole in the selector lever. Gradually tighten the nuts against the bracket, while continuing to check the fit of the swivel in the selector lever.

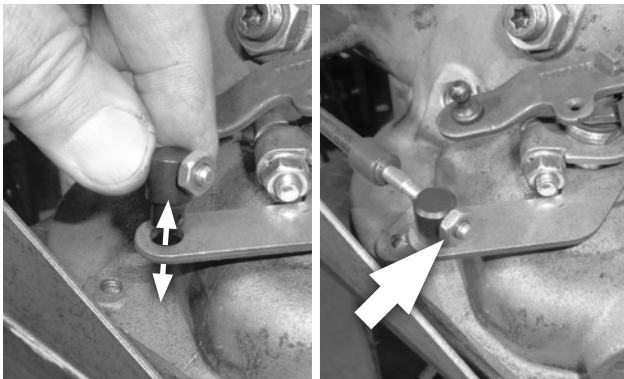

18. When the swivel slips freely in and out of the selector lever, snug the jam nut.

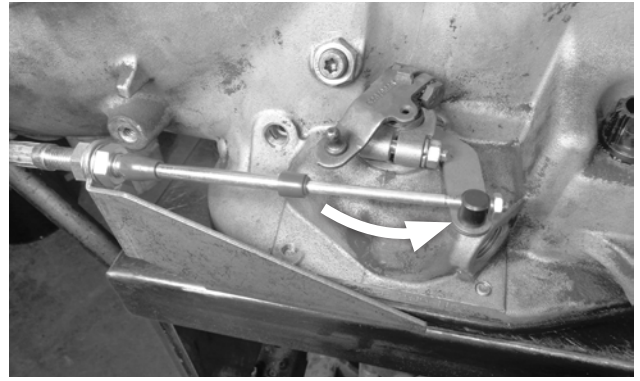

19. With the swivel still in the selector lever, move the shifter to the PARK (full-forward) position. Verify that the swivel still slips freely in and out of the selector lever. If not, adjust the large cable nuts (and the swivel, if necessary) until it does.

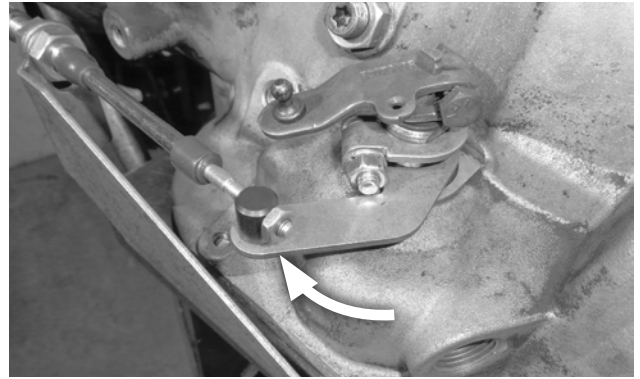

20. With the swivel still in the selector lever, operate the shifter through each position, verifying that the swivel slips freely in and out of the lever in each position.

CAUTION: If you encounter restricted movement or any other problem during this process, DO NOT FORCE THE SHIFTER. Doing so may damage the cable, the shifter and / or the transmission. Simply return to Step 17 and re-check each step.

When the swivel slips freely in and out of the selector lever in each position, the cable is correctly adjusted. Verify that the two large cable nuts, and the cable swivel jam nut, are tight.

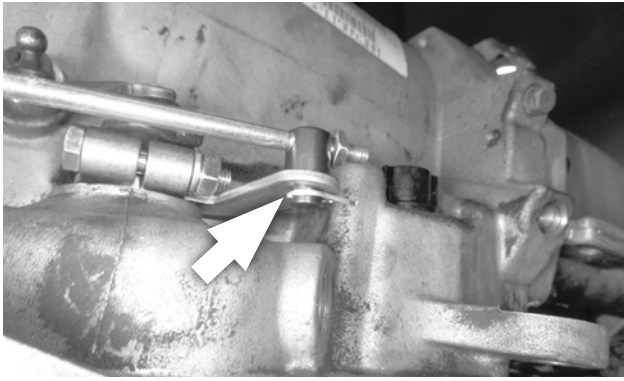

21. Secure the swivel to the selector lever with the cotter pin. Operate the shifter through all the gear positions, verifying that it operates correctly.

22. Check the operation of the throttle linkage again. The linkage must operate smoothly with no binding.

CAUTION: The throttle linkage must be connected and operating on all transmissions using automatic valve bodies, or transmission damage will result.

NEUTRAL SAFETY AND BACKUP LIGHT SWITCHES

1966-68 VEHICLES: The stock neutral safety switch will continue to function normally. Therefore, only the backup light switch on the shifter will be used.

23. Reroute the backup light switch wires: Disconnect the battery ground cable. Then disconnect the wires from the stock backup light switch (located on either the steering column, or the console shifter). Route the wires to the backup light (**upper**) switch on the shifter.

24. Wire the switch: Strip 1/4" of insulation off the wires and crimp a **terminal** to each wire, **using an appropriate crimping tool**.

CAUTION: Failure to use an appropriate tool to crimp the terminals may result in defective, unreliable connections.

Tape or heat-shrink the terminal-wire connections for added protection of the crimps. Connect the backup light wires to the UPPER switch (see **Step 8**).

25. Verify switch function: Reconnect the battery ground cable. Check the backup light switch by verifying the backup light is on only when the shifter is in REVERSE. If required, adjust the backup light switch as described at **Step 8**.

1969+ VEHICLES: The stock neutral safety and backup light switches are located on the transmission, and will continue to function normally. Therefore, neither of the switches on the shifter will be used.

Proceed to "Finish Installation," Step 61.

FORD

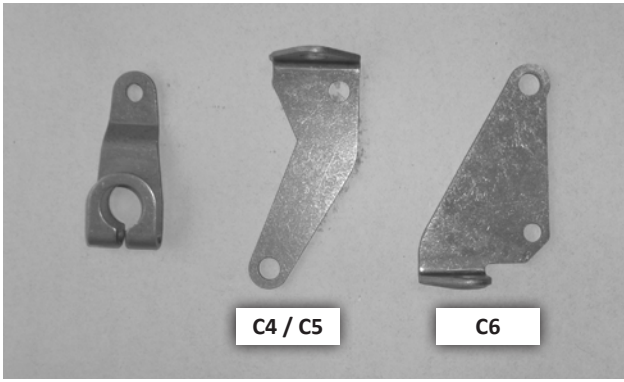

26. Get the Ford selector lever and appropriate cable bracket from the parts kit.

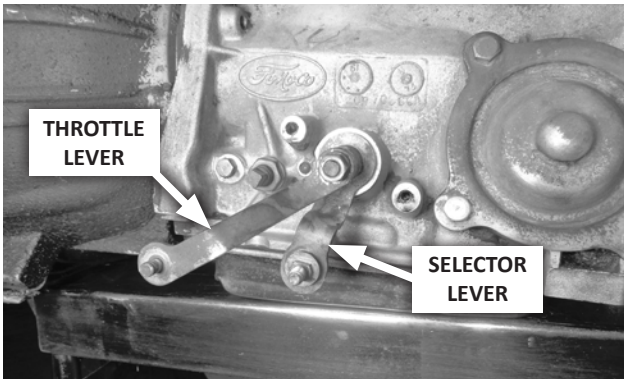

27. **Disconnect stock controls:** Remove and retain the nut and lock washer holding the throttle lever on its shaft. Carefully remove the throttle lever, and move it and its linkage aside, allowing them to hang free. Remove and discard the stock shift linkage.

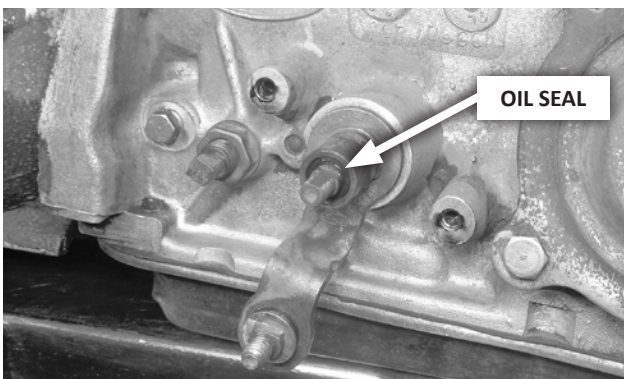

CAUTION: Ensure that the oil seal remains in place between the selector and throttle shafts. If the seal comes out, replace it before continuing.

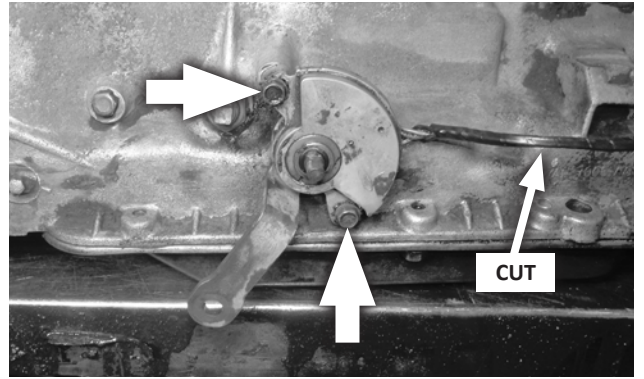

28. If your transmission is equipped with a neutral safety / backup light switch: Remove the two mount bolts and slide the switch off the selector shaft. Cut the wiring harness between the switch and its connector, and discard the switch. (The wires from the connector will be routed to the B&M switches later.)

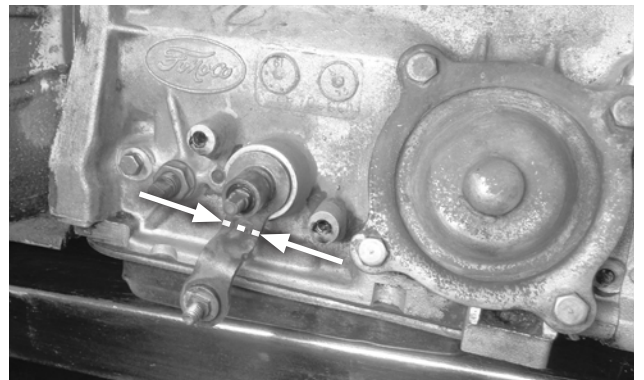

29. If the stock selector lever points generally downward, cut it off at the inboard bend, in order to allow the B&M lever to be positioned correctly.

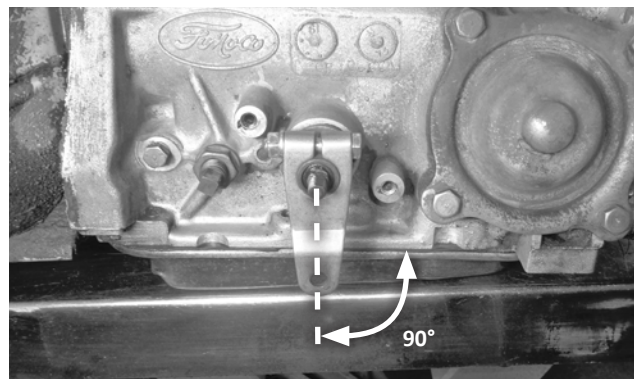

30. Install the B&M selector lever using the 1/4-20 x 1-1/2" bolt, and a 1/4" lock washer and nut. With the selector shaft in NEUTRAL (the second click back from PARK, which is full-forward), align the selector lever perpendicular to the oil pan split-line, then tighten the fasteners.

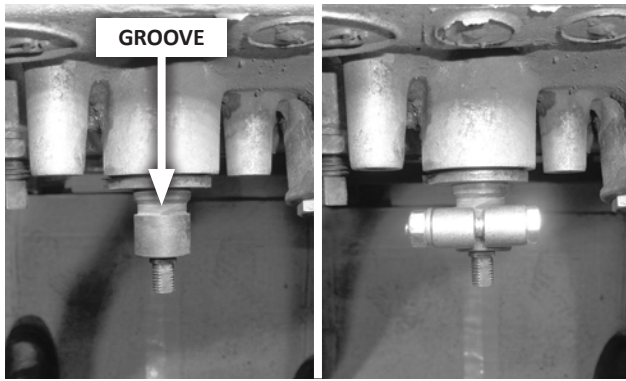

NOTE: If the selector shaft is grooved as shown, center the lever between the groove and the end of the shaft, so that the lever's inboard clamping surface does not land in the groove.

The lever should travel smoothly back and forth, with a positive "click" in each detent.

31. Install the cable bracket:

CAUTION: To avoid stripping out your transmission's bolt holes, use the correct bracket bolts. This kit includes both SAE and metric bracket bolts. (The metric bolts have finer threads.) To choose the correct kit bolts, compare them to the stock bolts you removed.

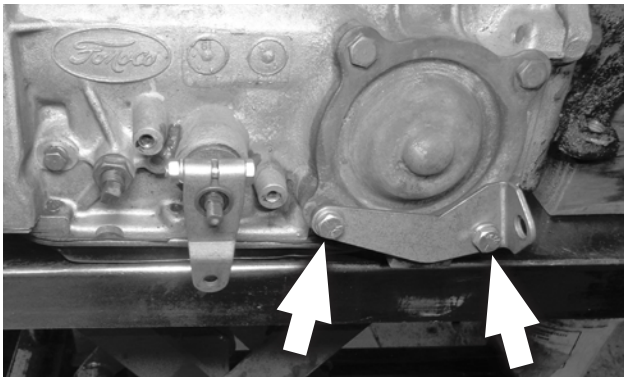

A. C4 / C5 transmissions: Install the **cable bracket** at the two lower servo cover bolt holes, using the two **5/16-18 x 1" bolts, flat washers and spacers**. Tighten the bolts to 12-13 ft-lbs torque.

CAUTION: Do not over-tighten the bolts, as this can distort the servo cover.

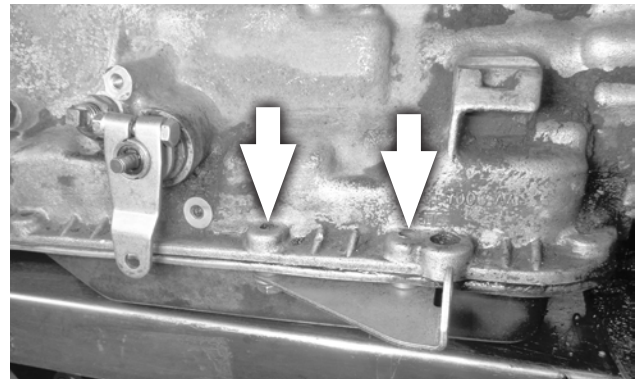

B. C6 transmissions: Install the **cable bracket** at the two left rear oil pan bolt holes, using the two **5/16-18 x 1" bolts and flat washers**. For stamped sheet-metal (stock) pans, use the two **spacers** between the pan and bracket. (Spacers are not used with cast aluminum pans.) Tighten the bolts to 12-13 ft-lbs torque.

CAUTION: Do not over-tighten the bolts, as this can damage the pan gasket.

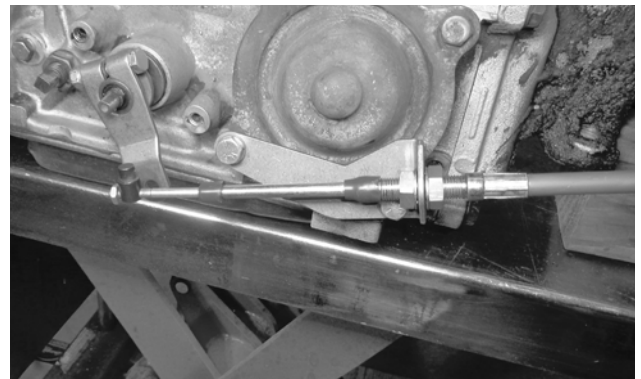

32. Attach the shifter cable to the cable bracket: First remove the small jam nut, two plastic dust boots, and one large nut and lock washer from the cable. Then insert the cable through the cable bracket, reinstall the lock washer and nut on the cable (loosely, to allow room for adjustment), and reinstall the two dust boots.



33. Thread the swivel onto the cable to about the middle of the threaded section, then reinstall (but do not tighten) the jam nut.

NOTE: Before proceeding, verify that the park and speed limiter pins are configured as described at **Step 6**.

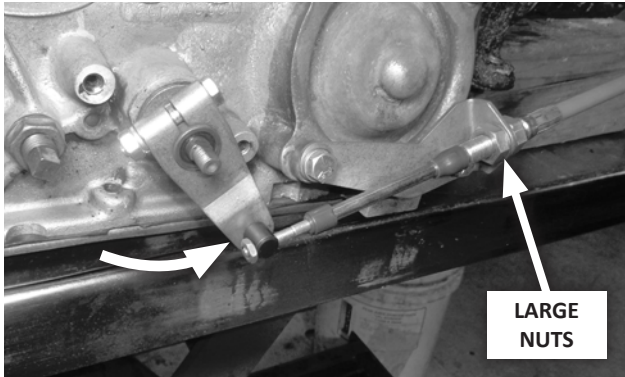

34. Manually move the selector lever to the LOW (full-rear) detent. Ratchet the shifter handle to the LOW position (furthest back). Adjust the large cable nuts until the swivel slides freely in and out of the hole in the selector lever. Gradually tighten the nuts against the bracket, while continuing to check the fit of the swivel in the selector lever.

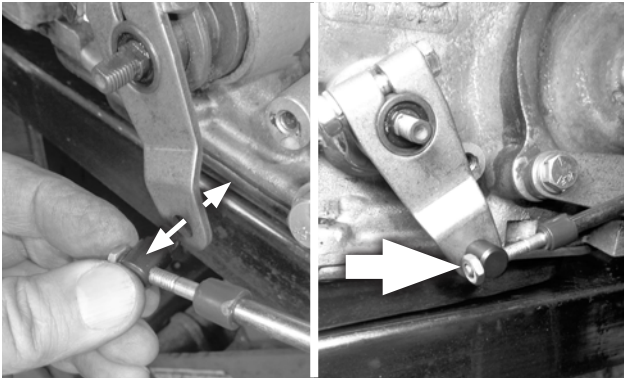

35. When the swivel slips freely in and out of the selector lever, snug the jam nut.

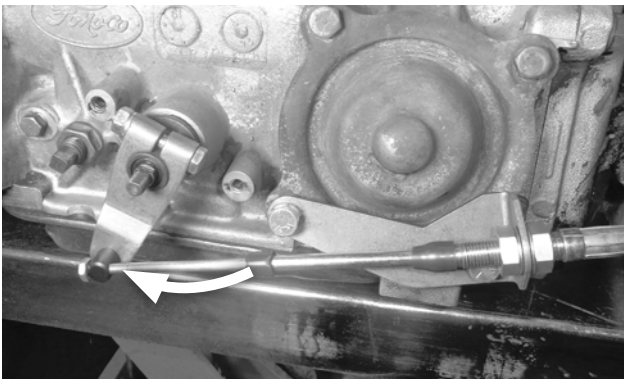

36. With the swivel still in the selector lever, move the shifter to the PARK (full-forward) position. Verify that the swivel still slips freely in and out of the selector lever. If not, adjust the large cable nuts (and the swivel, if necessary) until it does.

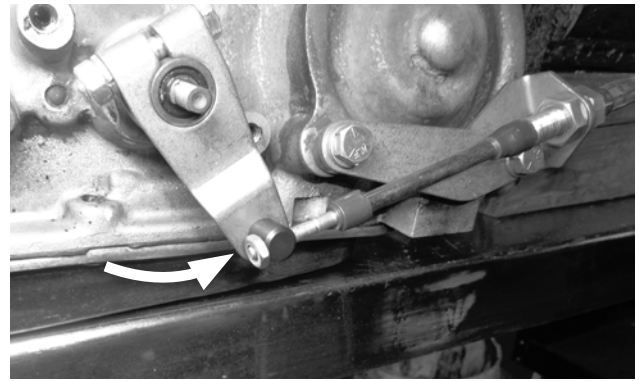

37. With the swivel still in the selector lever, operate the shifter through each position, verifying that the swivel slips freely in and out of the lever in each position.

CAUTION: If you encounter restricted movement or any other problem during this process, DO NOT FORCE THE SHIFTER. Doing so may damage the cable, the shifter and / or the transmission. Simply return to **Step 34** and re-check each step.

When the swivel slips freely in and out of the selector lever in each position, the cable is correctly adjusted. Verify that the two large cable nuts, and the cable swivel jam nut, are tight.

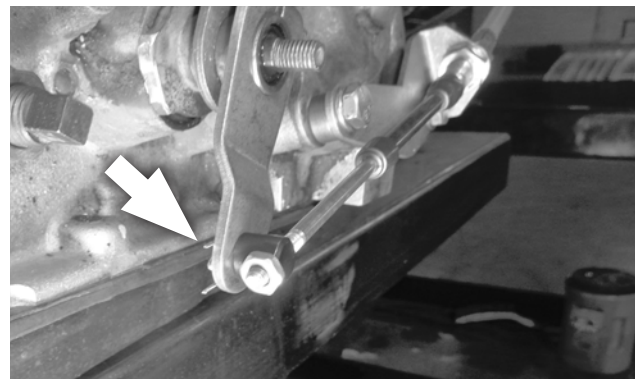

38. Secure the swivel to the selector lever with the cotter pin. Operate the shifter through all the gear positions, verifying that it operates correctly.

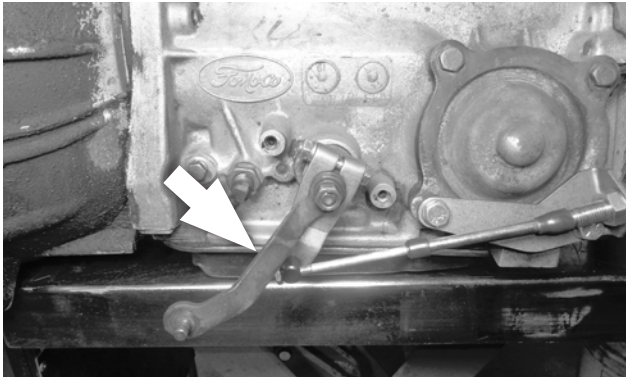

39. Reinstall the throttle lever, lock washer and nut on the throttle shaft and tighten securely. The throttle lever must operate smoothly with no binding.

CAUTION: The throttle linkage must be connected and operating on all transmissions using automatic valve bodies, or transmission damage will result.

NEUTRAL SAFETY AND BACKUP LIGHT SWITCHES

40. Reroute the switch wires: Use an applicable electrical schematic to locate and identify the two neutral safety circuit wires (which prevent cranking unless the transmission is in NEUTRAL or PARK), and the two backup light wires.

Disconnect the battery ground cable. Route both pairs of wires to the B&M QuickSilver shifter.

41. Wire the switches: Strip 1/4" of insulation off the wires and crimp a **terminal** to each wire, **using an appropriate crimping tool**.

CAUTION: Failure to use an appropriate tool to crimp the terminals may result in defective, unreliable connections.

Tape or heat-shrink the terminal-wire connections. Connect the backup light wires to the UPPER switch, and connect the neutral safety wires to the LOWER switch (see **Step 8**).

42. Verify switch function: Reconnect the battery ground cable, disconnect the coil wire and set the parking brake. Check the neutral safety switch by attempting to start the engine in each shifter position. The starter must crank only when the shifter is in either PARK or NEUTRAL. Check backup light operation with the shifter in REVERSE. If required, adjust the switches as described at **Step 8**. After verifying correct switch operation, reconnect the coil wire.

Proceed to "Finish Installation," Step 61.

GENERAL MOTORS

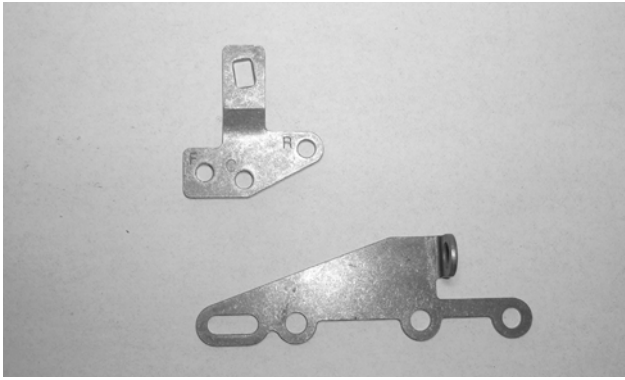

43. Get the GM selector lever and cable bracket from the parts kit.

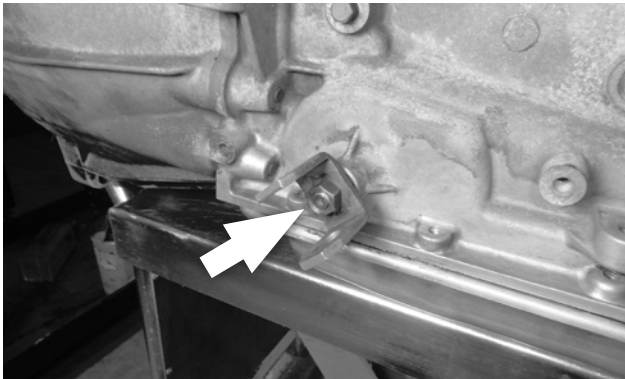

44. **Disconnect stock controls:** Remove and retain the selector lever nut. Remove and discard the selector lever and shift linkage.

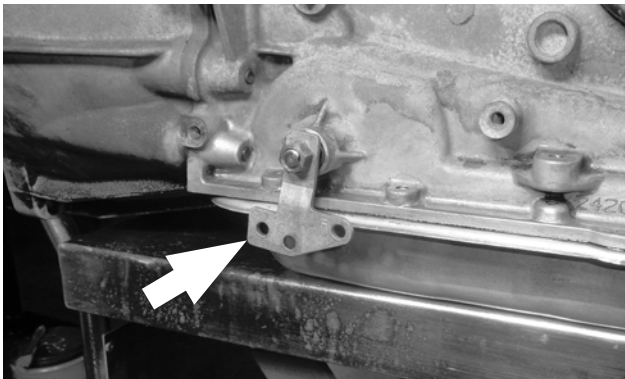

45. **Install the B&M selector lever** using the stock selector lever nut, and tighten the nut to 23 ft-lbs torque. The lever should travel smoothly back and forth, with a positive “click” in each detent.

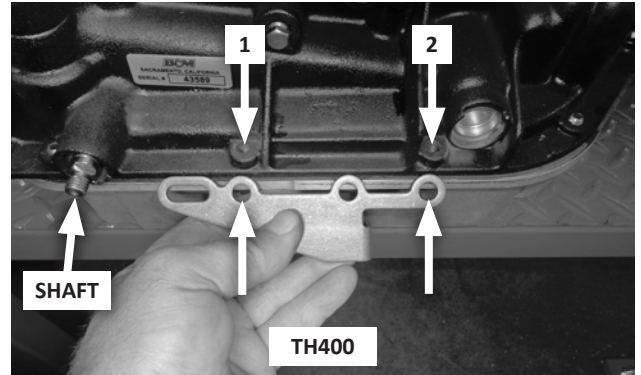
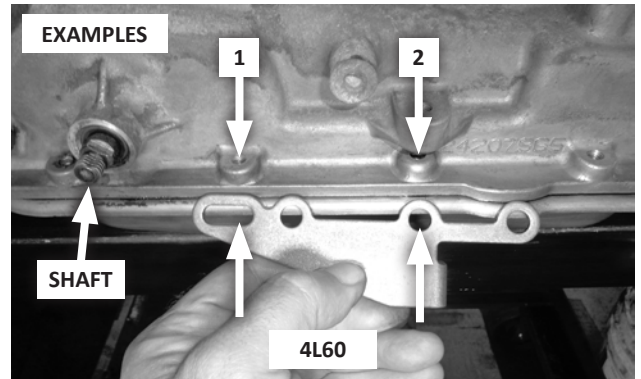

46. **Check cable bracket fit:** Remove the two oil pan bolts to the rear of the selector shaft. Determine which cable bracket holes will be used on your transmission.

CAUTION: To avoid stripping out your transmission’s bolt holes, use the correct bracket bolts. This kit includes both SAE and metric bracket bolts. (The metric bolts have finer threads.) To choose the correct kit bolts, compare them to the stock bolts you removed.

47. **Install the cable bracket** using either the two 5/16-18 × 1" (SAE), or the two M8-1.25 × 25 (metric) bolts, and two flat washers at the bracket holes that fit your transmission.

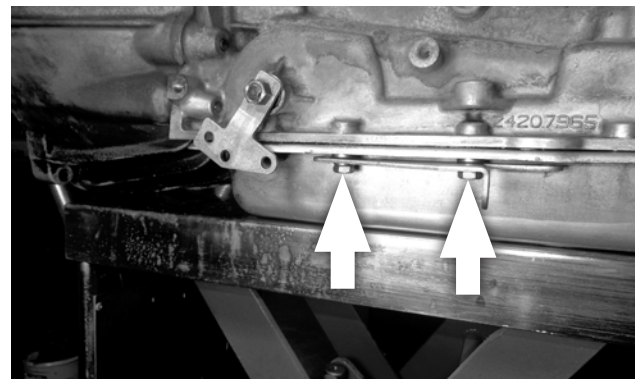

- A. **For stamped sheet-metal (stock) pans,** use the two spacers between the pan and bracket.

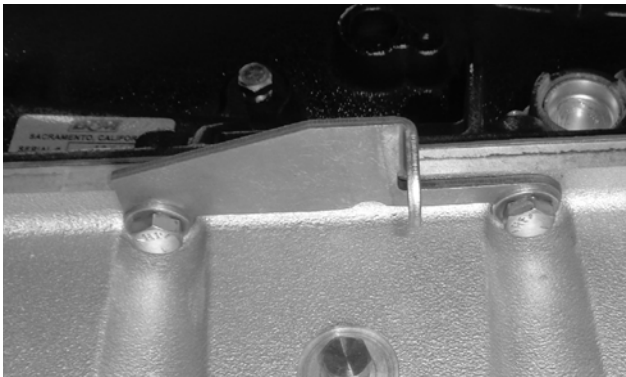
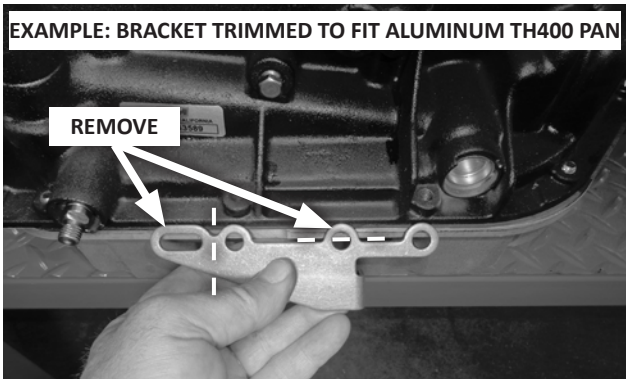

- B. For cast aluminum pans:**
- the bracket may need to be trimmed to fit; and
 - the spacers are not used.

Tighten the bolts to 12-13 ft-lbs torque.

CAUTION: Do not over-tighten the bolts, as this can damage the pan gasket.

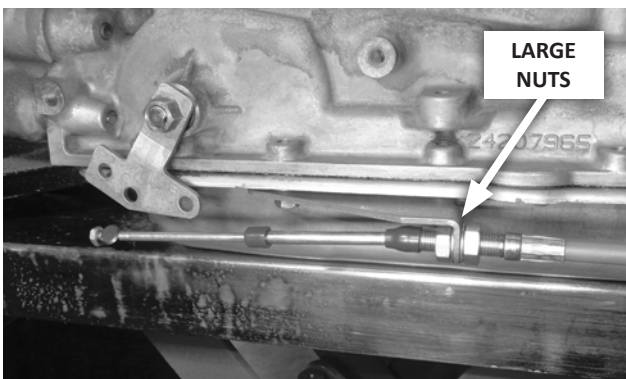

- 48. Attach the shifter cable to the cable bracket:** First remove the small jam nut, two plastic dust boots, and one large nut and lock washer from the cable. Then insert the cable through the cable bracket, reinstall the lock washer and nut on the cable (loosely, to allow room for adjustment), and reinstall the two dust boots.

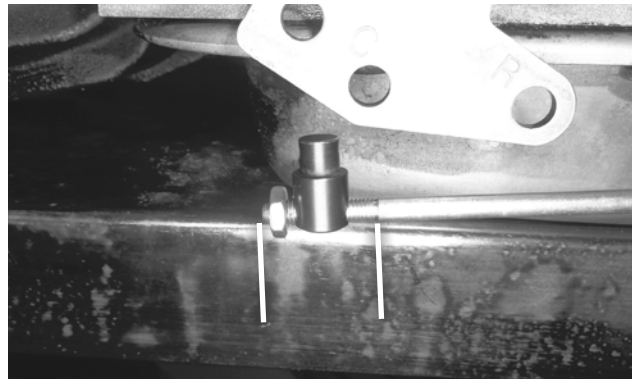

- 49. Thread the swivel onto the cable to about the middle of the threaded section, then reinstall (but do not tighten) the jam nut.**

NOTE: Before proceeding, verify that the park limiter pin is removed, and that the speed limiter pin is either installed (for 3-speed transmissions), or removed (for 4-speeds), as described at **Step 6**.

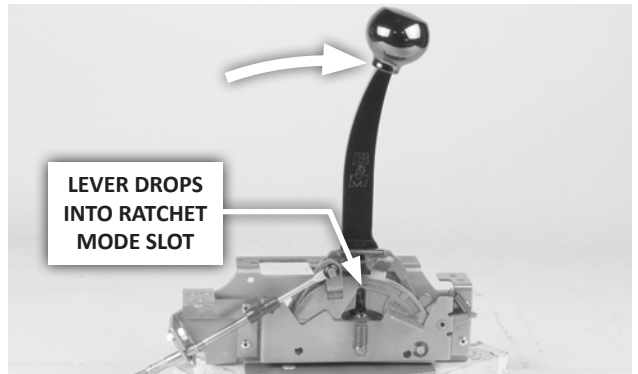

- 50. On the transmission, manually move the selector lever to the DRIVE detent (that is, 3 clicks back from full-forward / PARK). Then in the vehicle, move the shifter to the DRIVE position (4 clicks back from full-forward; the shift lever will drop into the ratchet mode slot).**

NOTE: Selector levers on GM transmissions travel twice the distance between PARK and REVERSE that they do between the remaining positions, which is why the QuickSilver shifter's park limiter pin is omitted for GM transmissions. With the pin removed, the shifter's full-forward position is PARK, and REVERSE is two clicks back. (One click back is the PARK position for Chrysler and Ford transmissions, and **should not be used** on GM transmissions.)

CAUTION: Once the shifter is installed, **NEVER** leave the vehicle parked in the position between **PARK** and **REVERSE!** The transmission's park pawl will not be engaged, which may allow the vehicle to roll! See "Operation" for further information.

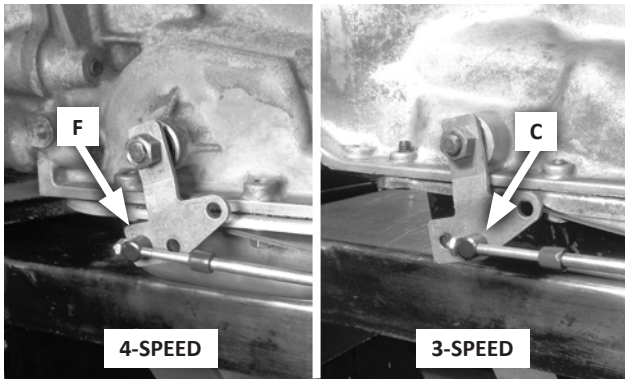

51. Adjust the large cable nuts until the swivel slides freely in and out of the correct hole in the selector lever (hole F for 4-speeds; hole C for 3-speeds). Gradually tighten the nuts against the cable bracket, while continuing to check the fit of the swivel in the selector lever.

CAUTION: The shifter will not operate properly unless the correct hole in the selector lever is used (hole F for 4-speeds, hole C for 3-speeds).

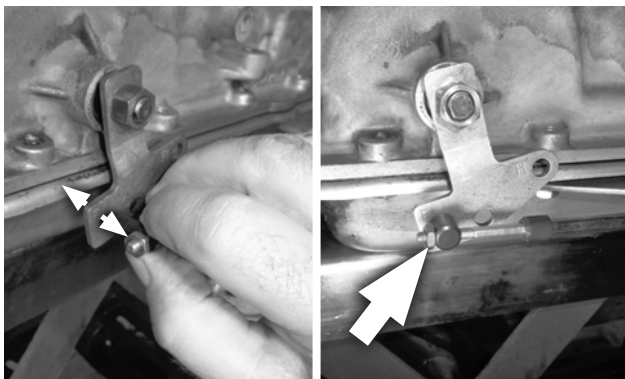

52. When the swivel slips freely in and out of the selector lever, snug the jam nut.

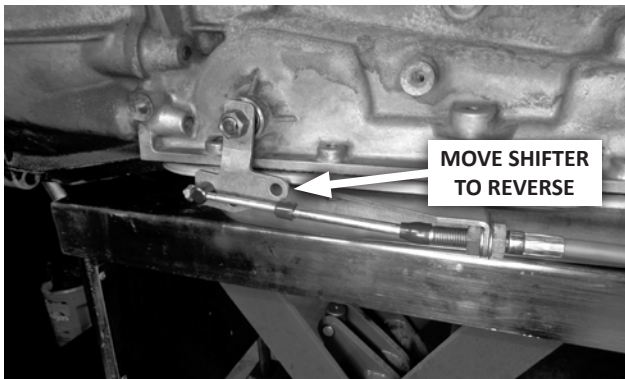

53. With the swivel still in the selector lever, lift the shifter lever and push it forward 2 clicks to REVERSE. Verify that the swivel still slips freely in and out of the selector lever. If not, adjust the large cable nuts (and the swivel, if necessary) until it does.

NOTE: You do not need to check the swivel fit in PARK. Internal tension in the transmission may interfere with proper adjustment in that position.

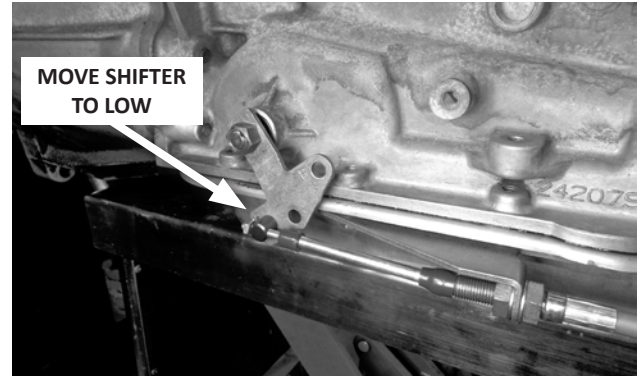

54. With the swivel still in the selector lever, ratchet the shifter back to your transmission's lowest gear (for 3-speeds), or to its second-lowest gear (for 4-speeds; see NOTE below), verifying that the swivel slips freely in and out of the lever in each position.

NOTE: On 4-speed transmissions, you do not need to check the swivel fit in FIRST gear. Internal tension in the transmission may not allow proper adjustment in that position. Checking the swivel's fit from REVERSE through SECOND gear is sufficient to attain proper adjustment.

CAUTION: If you encounter restricted movement or any other problem during this process, DO NOT FORCE THE SHIFTER. Doing so may damage the cable, the shifter and / or the transmission. Simply return to Step 50 and re-check each step.

When the swivel slips freely in and out of the selector lever from REVERSE through FIRST gear (on 3-speeds), or from REVERSE through SECOND gear (on 4-speeds), the cable is correctly adjusted. Verify that the two large cable nuts, and the cable swivel jam nut, are tight.

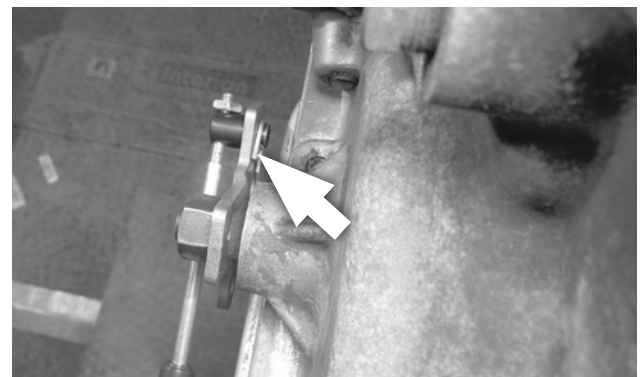

55. Secure the swivel to the selector lever with the cotter pin. Operate the shifter through all the gear positions, verifying that it operates correctly.

NEUTRAL SAFETY AND BACKUP LIGHT SWITCHES

56. Determine the type of neutral safety mechanism in your vehicle. It may be either:

- a **switch** on the stock shifter; or
- a **mechanical interlock** in the steering column that only allows the key to turn to START when the shifter is in PARK or NEUTRAL.

57. Reroute the switch wires: Disconnect the battery ground cable.

- A. Neutral safety switch:** Use an applicable electrical schematic to locate and identify the two neutral safety circuit wires (which prevent cranking unless the transmission is in NEUTRAL or PARK). Route both wires to the B&M shifter.
- B. Mechanical interlock:** Use an applicable electrical schematic to locate and identify the wire that runs between the START pole on the ignition switch and the starter relay or solenoid. (This is usually a purple, 10 or 12 AWG wire.) Cut the wire, and route both ends to the B&M shifter.

58. Backup light switch: Use an applicable electrical schematic to locate and identify the two backup light wires (usually located on the steering column behind the instrument panel). Route these wires to the B&M shifter.

59. Wire the switches: Strip 1/4" of insulation off the wires and crimp a **terminal** to each wire, **using an appropriate crimping tool**.

CAUTION: Failure to use an appropriate tool to crimp the terminals may result in defective, unreliable connections.

Tape or heat-shrink the terminal-wire connections. Connect the backup light wires to the UPPER switch, and connect the neutral safety wires to the LOWER switch (see **Step 8**).

60. Verify switch function: Reconnect the battery ground cable, disconnect the coil wire and set the parking brake. Check the neutral safety switch by attempting to start the engine in each shifter position. The starter must crank only when the shifter is in either PARK or NEUTRAL. Check backup light operation with the shifter in REVERSE. If required, adjust the switches as described at **Step 8**. After verifying correct switch operation, reconnect the coil wire.

FINISH INSTALLATION

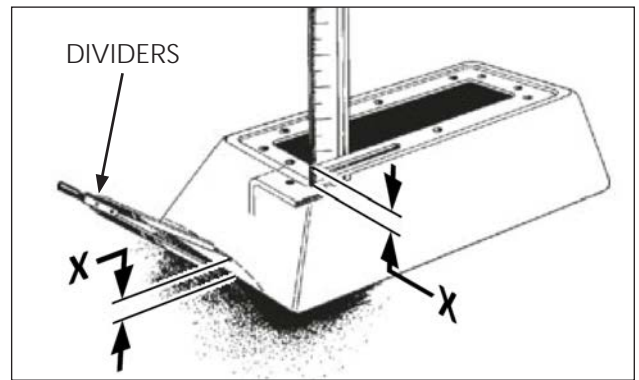

61. Place the tower over the shifter. Hold the **tower** level, with its bottom edge resting on the highest point on the floor that it will touch. Use a ruler to measure the dimension "X" — the distance from the shifter's tower mount tabs to the underside of the tower. Set a pair of dividers at dimension "X." While holding the tower in position, use the dividers to scribe a line on the tower to match the floor's contour. Remove the tower and use snips to remove material below the scribed line. Make small cuts, gradually working closer to the line, and continuing to check the tower's fit to the floor and shifter as you go. (**See Step 65 photos for proper alignment of shifter and tower screw holes.**) Once the tower is trimmed to fit, set it aside.

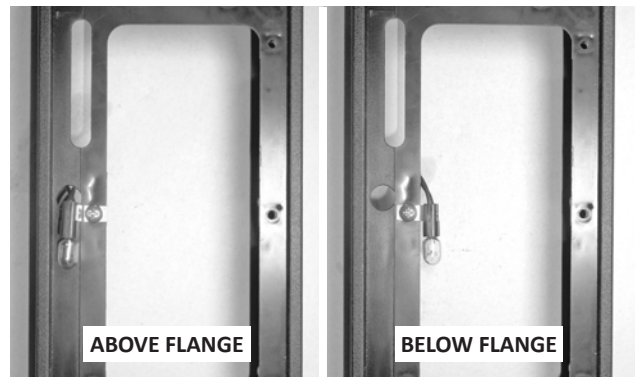

62. Assemble the indicator light and tower. Use the #10 × 3/8" screw to fasten the **indicator bulb socket** to the tower, with the socket pointing toward the rear. (The socket can be mounted above or below the tower flange, depending on the desired indicator brightness.) Then install the **light bulb** in the socket.

63. Place the tower over the shifter. Run a **power wire** from the vehicle's instrument light circuit to the shifter, and connect it to one of the bulb socket's wires. Connect the socket's other wire to a suitable chassis ground (for example, a shifter mount bolt). Tape or heat-shrink the connections and secure the wires as required.

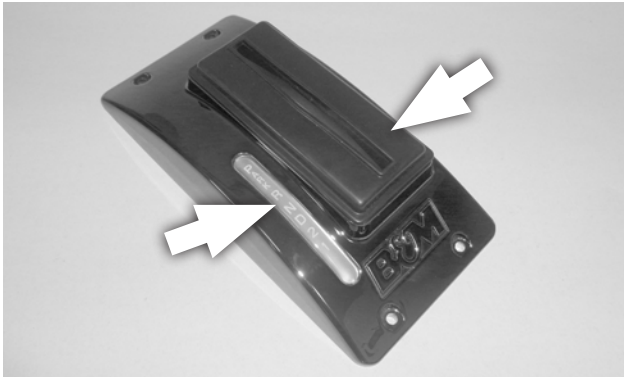

64. Install the **shifter boot** and the appropriate **indicator window** in the **tower cover**. (Use the 4-speed window for GM 4-speed transmissions only; use the 3-speed window for all others, including 4-speed Chryslers and Fords.)

NOTE: The two supplied indicator windows are for standard-pattern transmissions. **A window for reverse-pattern 3-speed transmissions is also available from B&M.**

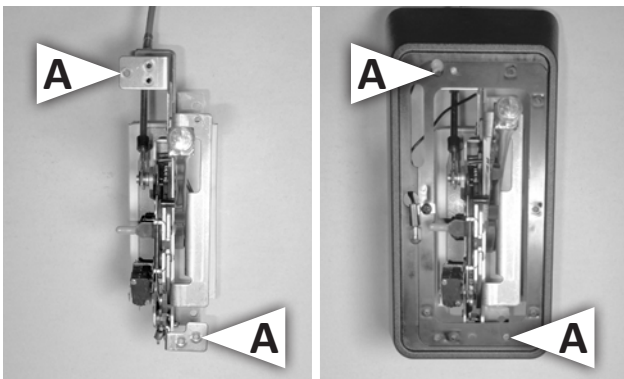

65. Verify the **shifter mechanism** is free of any debris and loose hardware. Remove the shift knob, and place the tower over the shifter. Align the tower's through-holes with the outboard screw holes on the shifter's front and rear brackets (at locations "A").

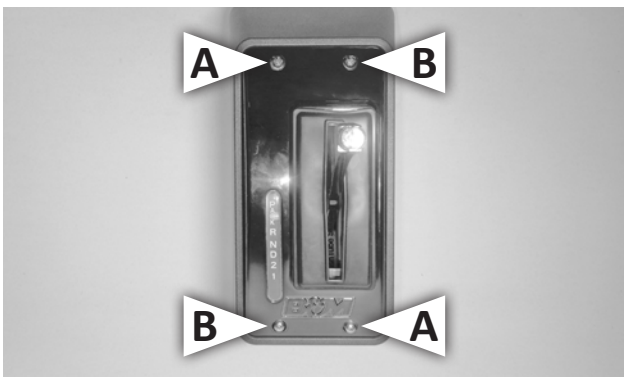

66. Place the assembled cover over the shift lever and tower. Hand-start two of the **10-32 × 3/4"** self-tapping screws

at hole locations "A" (through the tower, into the shifter's outboard screw holes). Then carefully start the other two **self-tapping screws** at hole locations "B" (to cut threads into the tower holes). Once all four screws are started, tighten them.

CAUTION: Do not over-tighten the screws, or the plastic cover may crack.



67. Apply **medium strength thread locker** to the shift lever threads. Carefully thread the **shift knob** all the way onto the lever and hand-tighten.

CAUTION: Avoid cross-threading! The knob should spin freely onto the lever with no resistance. **If you start to feel any resistance, STOP** and remove and re-align the knob.



68. Align the **shift knob insert** as desired, and snap it into place.

69. Fasten the **carpet** to the vehicle floor.

Congratulations! Your B&M QuickSilver™ shifter is now installed and ready to use.

INSTALLATION CHECKLIST

- Locking steering column lever is permanently fastened in the full up position (Step 1).
- Shifter is convenient to reach and has ample room for driver's hand throughout its range of motion (Step 2).
- Carpet covers floorboard holes (Step 5).
- Cable is connected to the shifter pin, and cable housing is securely fastened to the shifter base (Step 7).
- Shifter is securely mounted to floorboard (Step 9).
- Cable is routed clear of exhaust system, engine, and any moving parts (Step 10).
- Selector lever is securely installed on the transmission (Step 13, 30 or 45).
- Cable bracket bolts are tightened to 12-13 ft-lbs torque (Step 14, 31 or 47).
- Shifter is properly adjusted; cable boots are installed; cable nuts are tightened; swivel is secured with jam nut and cotter key (Steps 17-21; 34-38; or 50-55).
- The neutral safety switch is connected and properly adjusted to prevent engine start in FORWARD and REVERSE drive gears (Steps 40-42; or 56-60).
- There is no debris in the shifter mechanism (Step 61 B).
- Cover is installed (Step 61 E).
- Shifter moves freely into and out of all positions, as described in Shifter Operation.

CAUTION: If your shifter is not working properly do not attempt to drive your car! Verify you have followed all instructions. If the shifter is broken or defective return it to your B&M dealer.

OPERATION

NOTE: The shifter-transmission positions referred to below apply to standard-pattern transmissions (P-R-N-D-2-L). Reverse-pattern transmissions (P-R-N-L-2-D) will alter your shifter-transmission positions accordingly.

The **B&M QUICKSILVER™** shifter operates in Straight Gate mode from PARK through DRIVE. Once in DRIVE, the shifter operates in Ratchet Shift mode between all forward gear positions and NEUTRAL.

The following instructions may seem complicated at first, but not to worry — the **QUICKSILVER** shifter is easy to operate after just a brief time of familiarization.

STRAIGHT GATE MODE

From PARK, lift the shifter lever and pull it back into REVERSE (Figure 1). Once in REVERSE, the lever is simply pulled back into NEUTRAL, then again into DRIVE (where it drops into Ratchet Shift mode).

To get to PARK from DRIVE or NEUTRAL, lift the lever all the way up and push it all the way forward to the PARK position (Figure 2). To get to PARK from REVERSE, simply push the lever all the way forward.

NOTES:

- If you release the lever while pushing it forward out of DRIVE, it will stop at NEUTRAL, and you will need to lift it again to go into REVERSE.
- If you hold the lever up fully while pushing it forward out of DRIVE, you can move directly into REVERSE or PARK.

CAUTION: For GM transmissions, the shifter lever must be pushed FULLY FORWARD to put the transmission into PARK. **NEVER leave the vehicle parked with the shifter in the position between PARK and REVERSE, because the transmission's park pawl will not be engaged, allowing the vehicle to roll.**

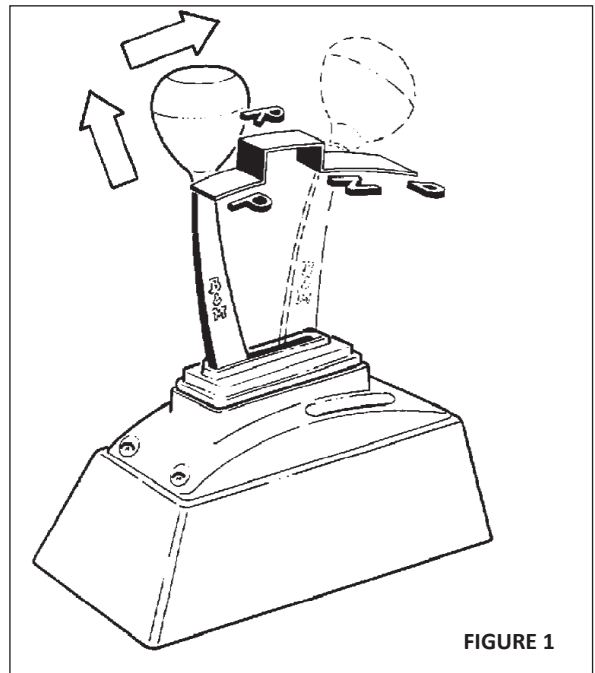

FIGURE 1

To get to REVERSE (whether from PARK, NEUTRAL or DRIVE), lift the lever to clear the Reverse Lockout and move the stick to the REVERSE position.

To get to NEUTRAL (in the Straight Gate range), from PARK

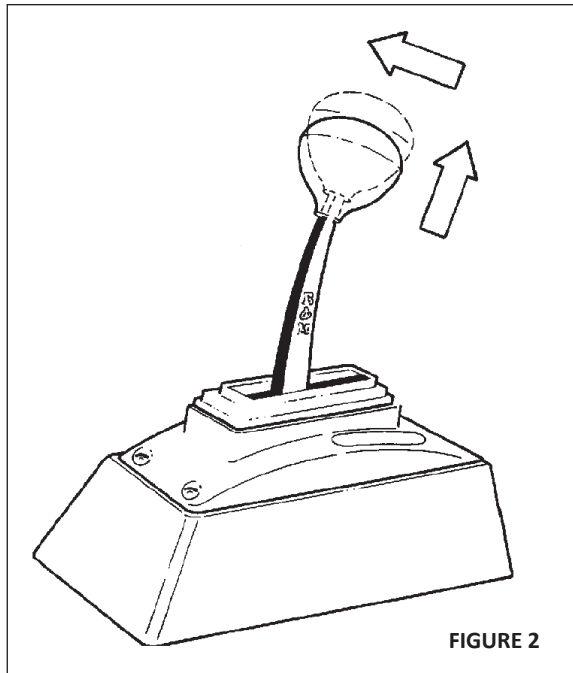

FIGURE 2

or DRIVE, lift the lever and move it to the NEUTRAL position. From REVERSE, simply pull the lever back into NEUTRAL.

To get to DRIVE, you do not have to raise the stick unless you are in PARK.

Your transmission's lower gears cannot be accessed directly when the shifter is in Straight Gate mode.

RATCHET SHIFT MODE

When the shift lever moves into DRIVE, it drops into the Ratchet Shift range (all forward gear positions and NEUTRAL; Figure 3).

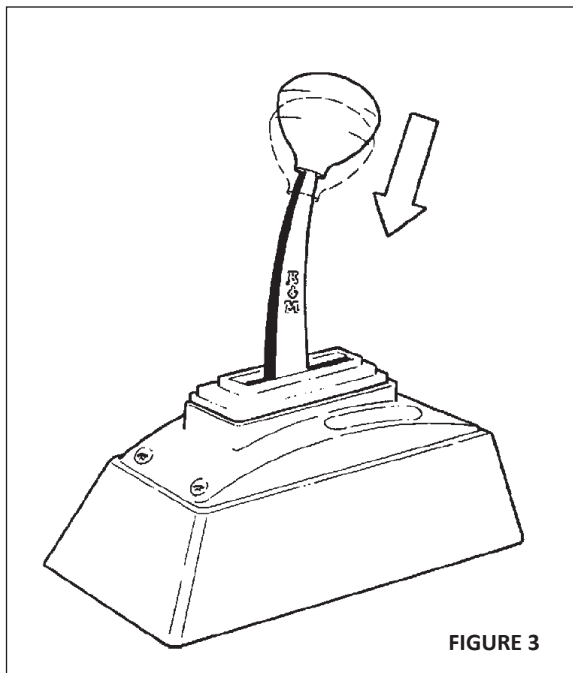

FIGURE 3

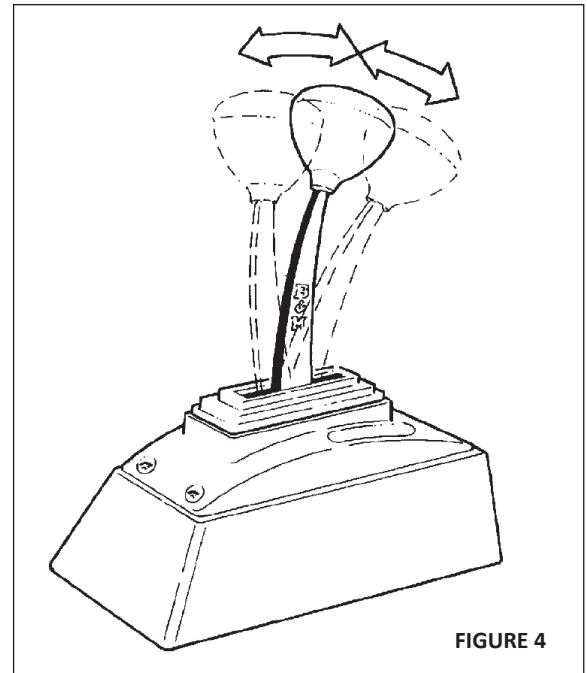

FIGURE 4

To shift the transmission in Ratchet Shift mode, simply pull or push the shift lever to a full stop then release it, allowing it to return to its "centered" position (Figure 4). Repeat this action until the transmission is in the desired gear.

To prevent unintended shifting into REVERSE, the shifter only operates in Ratchet Shift mode between the forward gears and NEUTRAL. To move from Ratchet Shift back to Straight Gate mode, first shift the transmission to DRIVE, then lift the shift lever up and push the handle forward to NEUTRAL, REVERSE or PARK (Figure 2). **IMPORTANT: RETAIN THESE INSTRUCTIONS FOR FUTURE REFERENCE**

KEEP THESE INSTRUCTIONS FOR FUTURE REFERENCE

B&M Performance & Off-Road maintains a highly-trained technical service department to answer your technical questions, provide additional product information and offer various recommendations.

